

Promizer

Power Electronics Systems

Energy Solutions

Facilities and Power Supplies

Enabling green IT with a safe and robust system Total Data Center System

Provides the full lineup of electrical equipment, allowing data centers to quickly start up the system and stabilize and optimize the power supply.

Fuji Electric provides an all-in-one, full array of services for data center electrical equipment — ranging from system design to installation through maintenance services — that help keep the power supply stable and optimized.

【Benefits】

- ✓ **Optimal equipment and systems are proposed based on customer specifications and tier requirements.**
- ✓ **Full lineup of substation equipment, UPSs, monitoring equipment, and security systems is provided.**
- ✓ **Infrastructure operation support and maintenance services are provided over the entire life cycle after the start of operation.**



【System features】

Substation equipment

- Substation equipment: High-reliability dual-system power receiving and redundant power distribution to servers
- Uninterruptible power supply: High reliability with redundant configuration matched to the tier level
- Monitoring equipment: Facility management system uses cloud services and an open environment

Substation equipment diagnostic services

- Remaining service life and deterioration assessment of power receiving and distribution panels
- Remaining service life and deterioration assessment of transformers
- Deterioration assessment of storage batteries

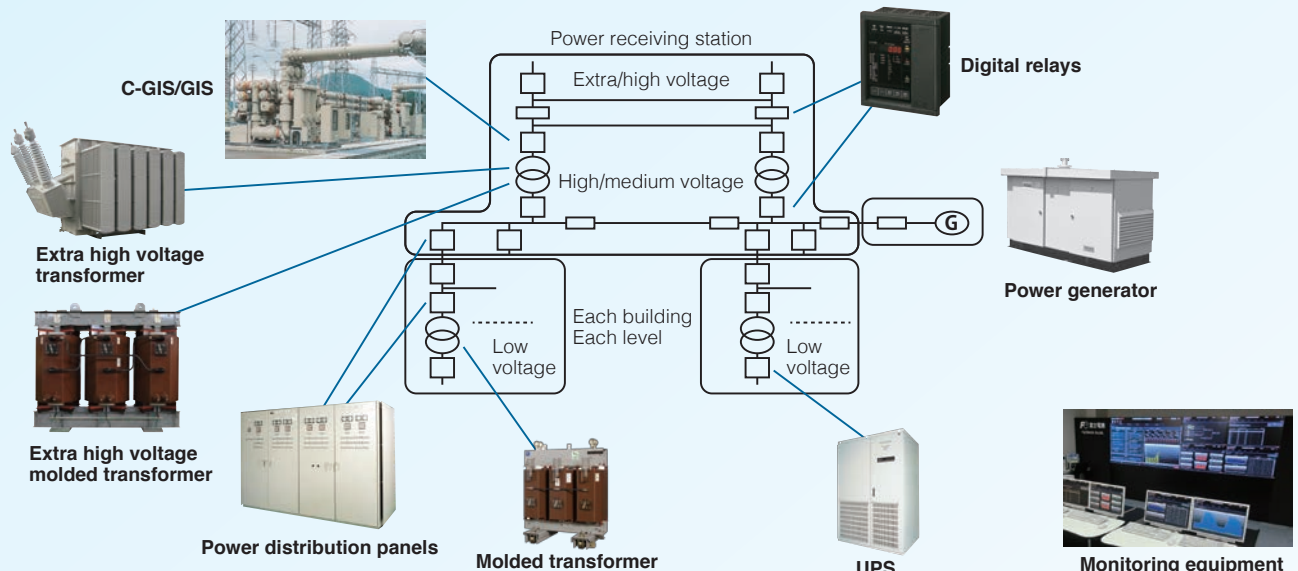

Key components of total data center system: Uninterruptible power supply (UPS)

【Functional overview】

Large-capacity uninterruptible power supply

- Highly scalable systems, including modular and parallel redundant configurations
- High-reliability power supply uses parallel redundancy and redundant power supply
- High-efficiency operations enabled by unit control functions, offline/standby UPS system mode, and peripheral devices such as Top Runner transformers

【Introduction examples】

Introduction example 1

Model: UPS7000HX series



Introduction example 2

Model: UPS7400WX series (UL standard compliant)



【System configuration】

Parallel-redundant, redundant power supply system

- Up to 8 UPS systems can be installed in parallel
- Maximum efficiency of 97%

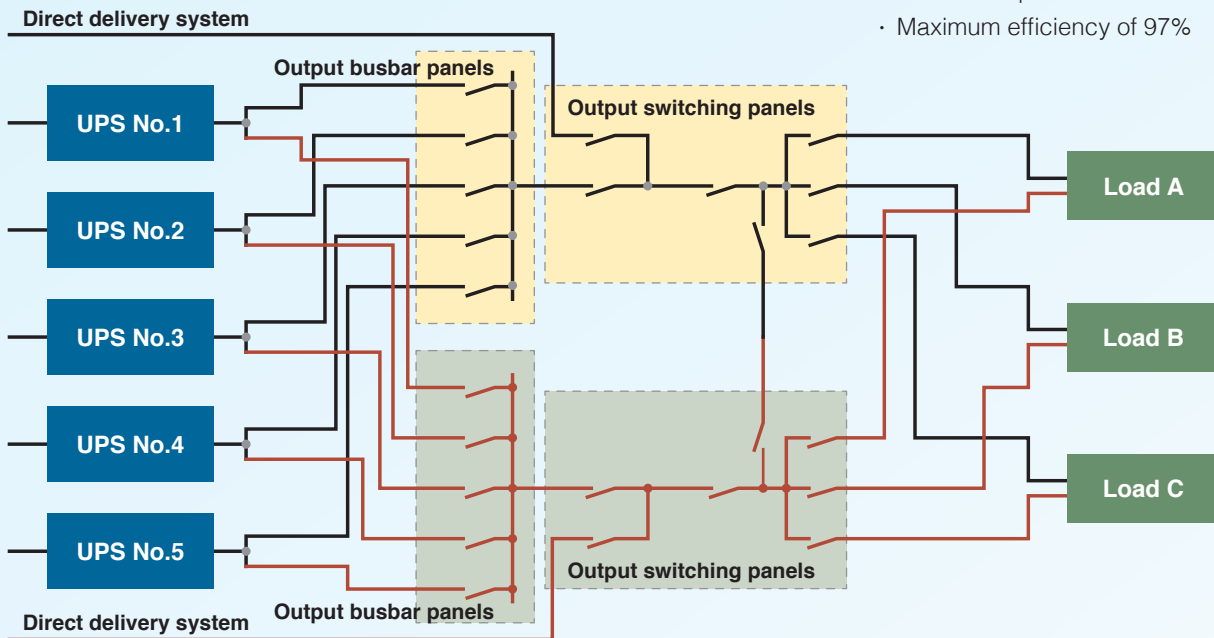

FE Fuji Electric Co., Ltd.

1, Fuji-machi, Hino-city, Tokyo 191-8502, Japan
Phone : +81-42-843-1332

Internet address : www.fujielectric.co.jp

Company names and product names in this catalog are acknowledged to be the trademarks or registered trademarks of their respective companies.
Note that the content of this publication may be changed due to product improvements or other reasons.

2020-12FOLS