

## Fuji 7<sup>th</sup> Generation IGBT-IPM X Series



# Application Manual

## Warning:

This manual contains the product specifications, characteristics, data, materials, and structures as of October 2021.

The contents are subject to change without notice for specification changes or other reasons. When using a product listed in this manual, be sure to obtain the latest specifications.

All applications described in this manual exemplify the use of Fuji's products for your reference only. No right or license, either express or implied, under any patent, copyright, trade secret or other intellectual property right owned by Fuji Electric Co., Ltd. is (or shall be deemed) granted. Fuji Electric Co., Ltd. makes no representation or warranty, whether express or implied, relating to the infringement or alleged infringement of other's intellectual property rights which may arise from the use of the applications described herein.

## Cautions

### (1) During transportation and storage

Keep locating the shipping carton boxes to suitable side up. Otherwise, unexpected stress might affect to the boxes. For example, bend the terminal pins, deform the inner resin case, and so on.

When you throw or drop the product, it gives the product damage.

If the product is wet with water, that it may be broken or malfunctions, please subjected to sufficient measures to rain or condensation.

Temperature and humidity of an environment during transportation are described in the specification sheet. There conditions shall be kept under the specification.

### (2) Assembly environment

Since this power module device is very weak against electro static discharge, the ESD countermeasure in the assembly environment shall be suitable within the specification described in specification sheet. Especially, when the conducting pad is removed from control pins, the product is most likely to get electrical damage.

### (3) Operating environment

If the product had been used in the environment with acid, organic matter, and corrosive gas (hydrogen sulfide, sulfurous acid gas), the product's performance and appearance can not be ensured easily.

## Chapter 3 Description of functions

1. List of functions	3-2
2. Description of functions	3-3
3. Truth table	3-8
4. Block diagram of IPM	3-9
5. Timing chart	3-11

This chapter describes the functions of the X series IPM.

## 1. List of functions

The built-in functions in the X series IPM are shown in Table 3-1 and 3-2.

Table 3-1 IPM built-in functions (6in1)

Number of Switch	Package	Built-in Function						
		Upper and Lower arms				Upper arm	Lower arm	
		Drive	UV	$T_{jOH}$	OC SC	ALM	ALM	WNG
6in1	P639	○	○	○	○	-	○	-
	P629	○	○	○	○	-	○	-
	P626	○	○	○	○	○	○	○
	P636	○	○	○	○	○	○	○
	P638	○	○	○	○	○	○	○
	P630	○	○	○	○	○	○	○
	P631	○	○	○	○	○	○	○

Drive: IGBT drive circuit, UV: Control power supply under voltage protection,  
 $T_{jOH}$ : IGBT chips over heating protection, OC: Over current protection,  
 SC: Short circuit protection, ALM: Alarm signal output, WNG: Chip temperature warning output

Table 3-2 IPM built-in functions (7in1)

Number of Switch	Package	Built-in Function						
		Upper and Lower arms				Upper arm	Lower arm	
		Drive	UV	$T_{jOH}$	OC SC	ALM	ALM	WNG
7in1	P644	○	○	○	○	○	○	-
	P636	○	○	○	○	○	○	-
	P630	○	○	○	○	○	○	-
	P631	○	○	○	○	○	○	-

Drive: IGBT drive circuit, UV: Control power supply under voltage protection,  
 $T_{jOH}$ : IGBT chips over heating protection, OC: Over current protection,  
 SC: Short circuit protection, ALM: Alarm signal output, WNG: Chip temperature warning output

## 2. Description of functions

### 2.1 IGBT and FWD for 3-phase inverter

The IPM has a 3-phase bridge circuit which consists of IGBTs and FWDs as shown in Figure 3-1. The main circuit is completed when the main DC bus power supply line is connected to the P and N terminals and the 3-phase output line is connected to the U, V and W terminals. Connect a snubber circuit to suppress the surge voltage.

### 2.2 IGBT and FWD for brake

IGBT and FWD for brake circuit are integrated in and the collector terminal of the IGBT is connected to the output terminal B as shown in Figure 3-1. The regenerative energy during deceleration is dissipated by the resistor which is connected between terminal P and B. Voltage rise between terminal P and N can be suppressed by switching the brake IGBT.

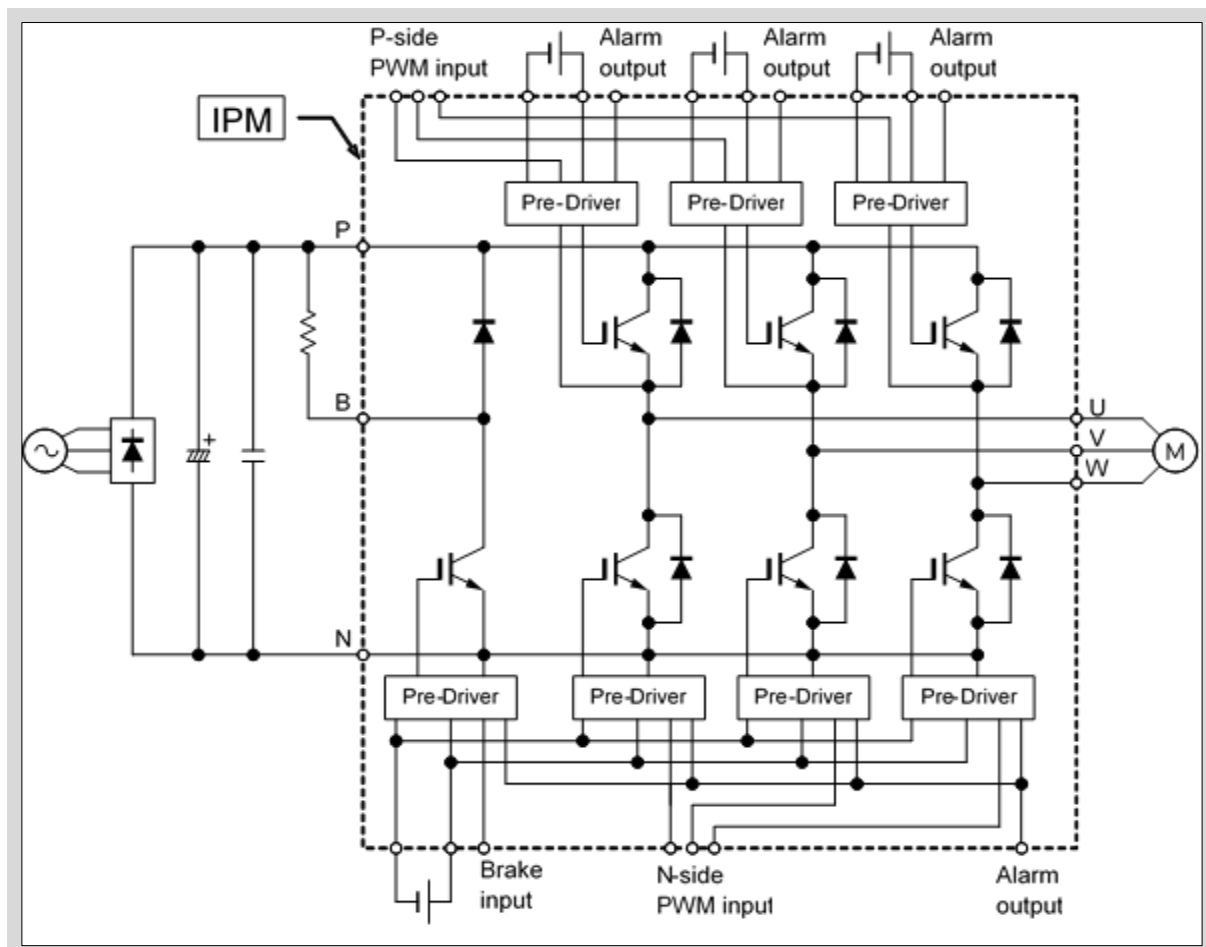

Fig.3-1 Typical application of 3-phase inverter (Example: 7MBP250XDA065-50 with built-in brake)

### 2.3 IGBT drive function

Figure 3-2 shows a block diagram of the Pre-Driver. The IPM has a built-in gate driving circuit for the IGBT and it is possible to drive the IGBT by providing an opto-isolated control signal to the IPM without designing a gate driving circuit.

The features of this drive function are introduced below:

▣ Independent turn-on and turn-off control

The IPM has independent gate driving circuits for turn-on and turn-off. Therefore, the driving circuits control the  $dv/dt$  of turn-on and turn-off independently and maximize the performance of the device.

▣ Soft shutdown

The gate voltage is gradually reduced when the IGBT is turned-off by the protection function in various kinds of abnormal modes. This soft shutdown suppresses the surge voltage during turn-off and prevents the IPM from being destroyed.

▣ Prevention of false turn-on

The gate terminal of the IGBT is connected to the grounded emitter with low impedance. It prevents false turn-on of the IGBT due to  $V_{GE}$  rising resulting from noise or other cause.

▣ No reverse bias power supply is necessary

Since the wiring length between the control IC and the IGBT in the IPM are short, the wiring impedance is small. Therefore, the IPM can be driven without reverse bias.

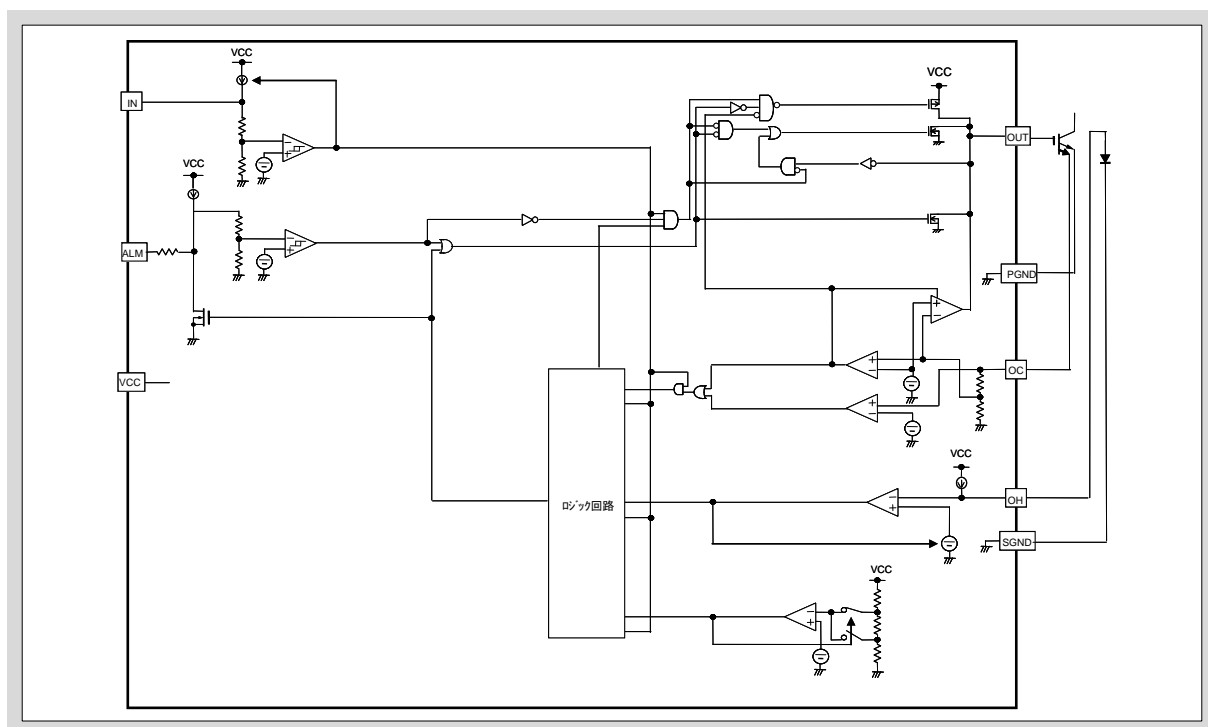

Fig.3-2 Pre-Driver block diagram (Example:7MBP250XDA065-50)

## 2.4 Protection functions

The IPM has protection circuits that protect the IPM from abnormal modes. The IPM has four types of protection functions; OC (over current protection), SC (short circuit protection), UV (control power supply under voltage protection) and  $T_{jOH}$  (IGBT chips over heating protection).

When a protective function is activated, the MOSFET for alarm output is turned on, the alarm output signal voltage changes from High to Low, and the alarm output terminal conducts to GND.

Furthermore, since a 1.3k $\Omega$  resistance is connected in series between the control IC and the alarm output terminal, an optocoupler that is connected between the ALM terminal and the  $V_{CC}$  terminal can be directly driven.

### □ Alarm signal output function

If the abnormal mode is detected, the IGBT is slowly turned off. The alarm signal is output from the phase in which abnormal mode is detected. During the protection period, the IGBT is not turned on even if the control input signal is in ON-state.

- After the elapse of  $t_{ALM}$ , if the alarm factor has been resolved, and the control input signal is OFF-state, the protection operation is reset and normal operation is resumed.
- Even if the alarm factor is resolved within the alarm signal output period ( $t_{ALM}$ ), the protection operation continues during the alarm signal output period ( $t_{ALM}$ ), and the IGBT will not turn on. If the control input signal is OFF-state after the alarm signal output period ( $t_{ALM}$ ) has elapsed, the protection operation is reset and normal operation is resumed.
- On the upper arm side, the IGBT of the phase that detected the abnormal mode shutdown softly and stops operation.
- On the lower arm side, when each phase of the inverter section goes into protection, all IGBTs of the lower arm except the brake IGBT shutdown softly and stop operation. The brake IGBT can be operated. Also, in the event of an abnormality in the brake section, all IGBTs in the lower arm and brake IGBT will shutdown softly and stop operation.

\* P629 and P639 package have protection functions on both of the upper arm and the lower arm devices, but the upper arm devices do not have an alarm signal output function. The lower arm devices have both the protective functions and alarm signal output function.

### □ Alarm factor identification function

As the alarm signal output period ( $t_{ALM}$ ) varies in correspondence to the failure mode, the failure mode can be identified by measuring the alarm signal pulse width.

Alarm factor	Alarm signal output period ( $t_{ALM}$ )
Over current protection(OC) Short-circuit protection(SC)	2ms(typ)
Control power supply under voltage protection(UV)	4ms(typ)
Chip temperature overheat protection( $T_{jOH}$ )	8ms(typ)

However, the pulse width of the alarm signal output through an optocoupler varies depending on the delay time of the optocoupler and the influence of peripheral circuits. It is necessary to take these influences into account in your design.



### 2.5 Over current protection function (OC)

The collector current of IGBTs is detected by the current sense IGBT built into the IGBT chip. If the collector current reaches the over current protection level ( $I_{OC}$ ) and continues for more than the over current protection delay time ( $t_{dOC}$ ), it is determined as being in the OC status and the IGBT is turned off to prevent destruction due to over current.

When the OC status is detected, the protection function is activated and an alarm signal is output. The OC status alarm signal output period ( $t_{ALM}$ ) is approximately 2ms.

- Protection operation is reset after 2ms ( $t_{ALM}$ ) and normal operation is resumed if the current level is lower than the  $I_{OC}$  level and the control input signal is OFF.
- Even if the alarm factor is resolved within 2ms ( $t_{ALM}$ ), the protection operation continues until the period of 2ms ( $t_{ALM}$ ) elapses. During this period, the IGBT will not be turned on.

### 2.6 Short circuit protection function (SC)

The SC protection function prevents the IPM from being damaged by the peak current during load short circuit and arm short circuit. If the IGBT collector current exceeds the protection level ( $I_{SC}$ ) and continues for more than the short circuit protection delay time ( $t_{sc}$ ), it is determined as being in the SC status and the IGBT is turned off softly to prevent destruction due to short circuit.

When the SC status is detected, the protection function is activated and an alarm signal is output. The SC status alarm signal output period ( $t_{ALM}$ ) is approximately 2ms.

- Protection operation is reset after 2ms ( $t_{ALM}$ ) and normal operation is resumed if the current level is lower than the  $I_{SC}$  level and the input signal is OFF.
- Even if the alarm factor is resolved within 2ms ( $t_{ALM}$ ), the protection operation continues until the period of 2ms ( $t_{ALM}$ ) elapses. During this period, the IGBT will not be turned on.

### 2.7 Control power supply under voltage protection function (UV)

The UV protection function prevents malfunction of the control IC caused by voltage drop of the control power supply voltage ( $V_{CC}$ ), and protects the IGBT from thermal destruction caused by increase of  $V_{CE(sat)}$  loss. When  $V_{CC}$  is continuously below the under voltage protection level ( $V_{UV}$ ) for about 20 $\mu$ s, it is determined as being in the UV status and the IGBTs are turned off softly to prevent malfunction and thermal destruction due to control power supply voltage drop.

When the UV status is detected, the protection function is activated and an alarm signal is output. The UV status alarm signal output period ( $t_{ALM}$ ) is approximately 4ms.

- As hysteresis  $V_H$  is provided, protection operation is reset after 4ms ( $t_{ALM}$ ) and normal operation is resumed if  $V_{CC}$  is higher than ( $V_{UV} + V_H$ ) and the input signal is OFF.
- Even if the alarm factor is resolved within 4ms ( $t_{ALM}$ ), the protection operation continues until the period of 4ms ( $t_{ALM}$ ) elapses. During this period, the IGBT will not be turned on.

Furthermore, an alarm signal to determine the UV status is provided at the time of startup and shutdown of the control power supply  $V_{CC}$ .

## 2.8 IGBT chips over heating protection function ( $T_{jOH}$ )

Over heating protection function detects the IGBT chip surface temperature by the built-in temperature sensor on each IGBT chip. If the IGBT chip temperature continuously exceeds the over heating protection level ( $T_{jOH}$ ) for about 1ms, the IGBT is judged to be in an over heating state and the IGBT is turned off softly to prevent thermal destruction.

When the  $T_{jOH}$  state is detected, the protection function is activated and alarm signal is output. The  $T_{jOH}$  state alarm signal output period ( $t_{ALM}$ ) is approximately 8ms.

- As hysteresis  $T_{jH}$  is provided, protection operation is reset after 8ms ( $t_{ALM}$ ) and normal operation is resumed if  $T_{vj}$  is below ( $T_{jOH} - T_{jH}$ ) and the input signal is OFF.
- Even if the alarm factor is resolved within 8ms ( $t_{ALM}$ ), the protection operation continues until the end of the period of 8ms ( $t_{ALM}$ ) elapses. During this period, the IGBT will not be turned on.

The case temperature over heating protection function ( $T_{cOH}$ ), which is built in the previous IPM series, is not built in this X series. The IGBT chip is protected by the  $T_{jOH}$  protection function.

## 2.9 Temperature warning output function ( $T_{jW}$ )

Temperature warning output function directly detects the IGBT chip surface temperature by the built-in temperature sensor on the Y phase IGBT chip. If the IGBT chip temperature continuously exceeds the warning temperature level ( $T_{jW}$ ) for about 1ms, the IGBT is judged to be in an over heating state and a temperature warning signal is output from the warning signal output terminal. With this function, it is possible to determine in advance that the IPM is overheated before it is stopped by over heating protection. During this state, the over heating protection function and alarm signal output function will not operate. (Even if the temperature warning output signal is generated, the protection is not activated and the IPM continues to operate.) The temperature warning signal output period ( $t_{WNG}$ ) continues until the factor is released.

- As hysteresis  $T_{jWH}$  is provided, warning output signal is canceled if  $T_{vj}$  is below ( $T_{jW} - T_{jWH}$ ).

This function is available only in the Fuji 7<sup>th</sup> generation X series IGBT-IPM in the following package. P626 , P636(6in1) , P638 , P630(6in1) , P631(6in1)

### 3. Truth table

The truth table when a failure occurs are shown in Table 3-3.

Table 3-3 Truth table

	Alarm factor	IGBT					Alarm output signal				Warning output signal
		U-phase	V-phase	W-phase	X,Y,Z-phase	B-phase	ALM-U	ALM-V	ALM-W	ALM-Low side	WNG
U-phase	OC	OFF	*	*	*	*	Low	High	High	High	*
	SC	OFF	*	*	*	*	Low	High	High	High	*
	UV	OFF	*	*	*	*	Low	High	High	High	*
	$T_{jOH}$	OFF	*	*	*	*	Low	High	High	High	*
V-phase	OC	*	OFF	*	*	*	High	Low	High	High	*
	SC	*	OFF	*	*	*	High	Low	High	High	*
	UV	*	OFF	*	*	*	High	Low	High	High	*
	$T_{jOH}$	*	OFF	*	*	*	High	Low	High	High	*
W-phase	OC	*	*	OFF	*	*	High	High	Low	High	*
	SC	*	*	OFF	*	*	High	High	Low	High	*
	UV	*	*	OFF	*	*	High	High	Low	High	*
	$T_{jOH}$	*	*	OFF	*	*	High	High	Low	High	*
X,Y,Z-phase	OC	*	*	*	OFF	*	High	High	High	Low	*
	SC	*	*	*	OFF	*	High	High	High	Low	*
	UV	*	*	*	OFF	*	High	High	High	Low	*
	$T_{jOH}$	*	*	*	OFF	*	High	High	High	Low	*
Y-phase	$T_{jW}$	*	*	*	*	*	High	High	High	High	Low
B-phase	OC	*	*	*	OFF	OFF	High	High	High	Low	*
	SC	*	*	*	OFF	OFF	High	High	High	Low	*
	UV	*	*	*	OFF	OFF	High	High	High	Low	*
	$T_{jOH}$	*	*	*	OFF	OFF	High	High	High	Low	*

\* Dependent on the input signal.

※P639 and P629 do not have ALM output for the upper arm (U, V, W phase).

The brake phase can operate normally even if the lower arm X, Y, and Z phases are under protection. When the protection operation is activated in the brake phase, all the lower arm phases including the brake phase go into protection state.

## 4. Block diagram of IPM

IPM block diagrams are shown in Figure 3-3 to 3-5.

Figure 3-3 shows an example of P629 (6in1) without alarm functions on the upper arms.

Figure 3-4 shows an example of P630 (6in1) and Figure 3-5 shows an example of P630 (7in1).

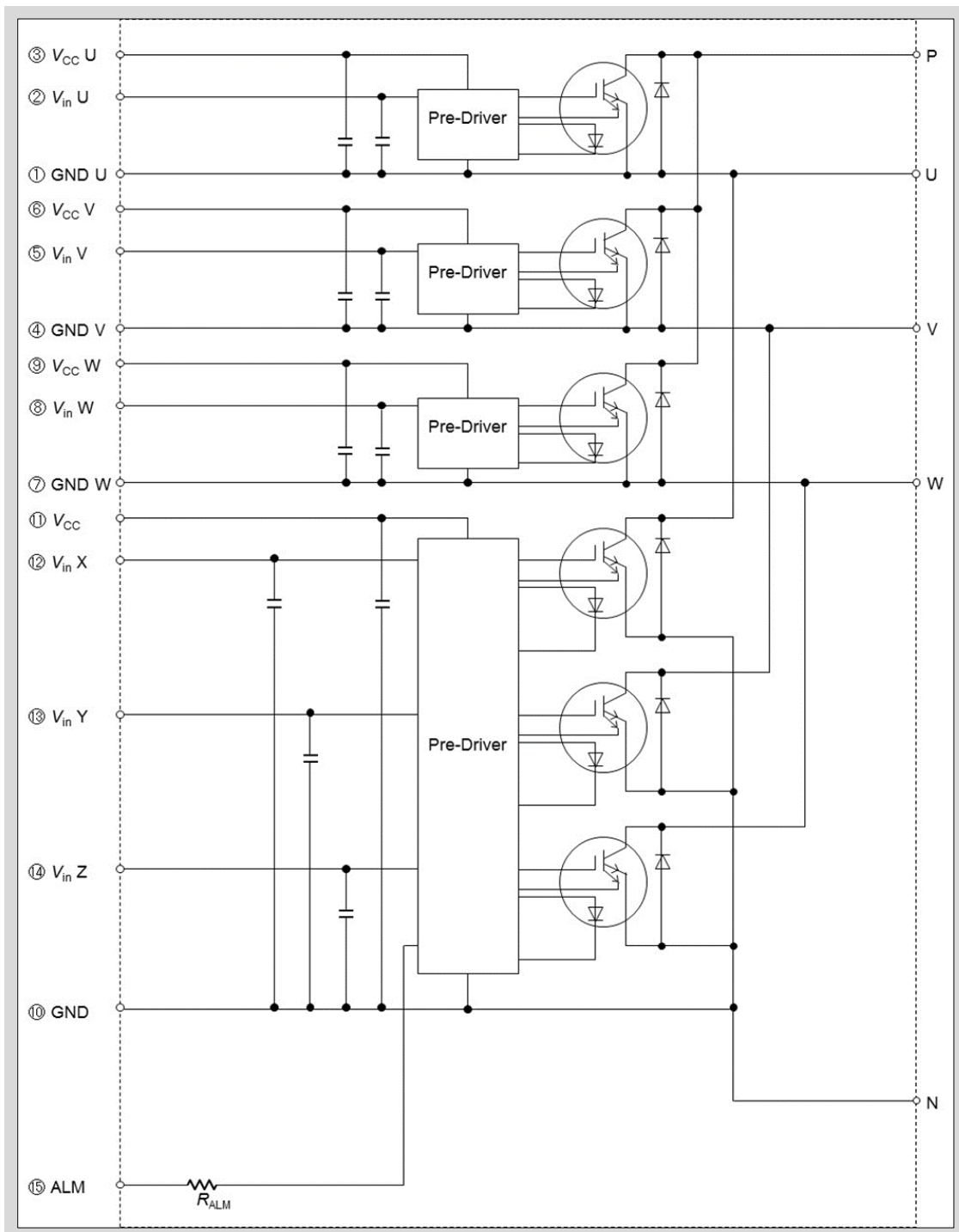

Fig. 3-3 IPM block diagram (example: P629)

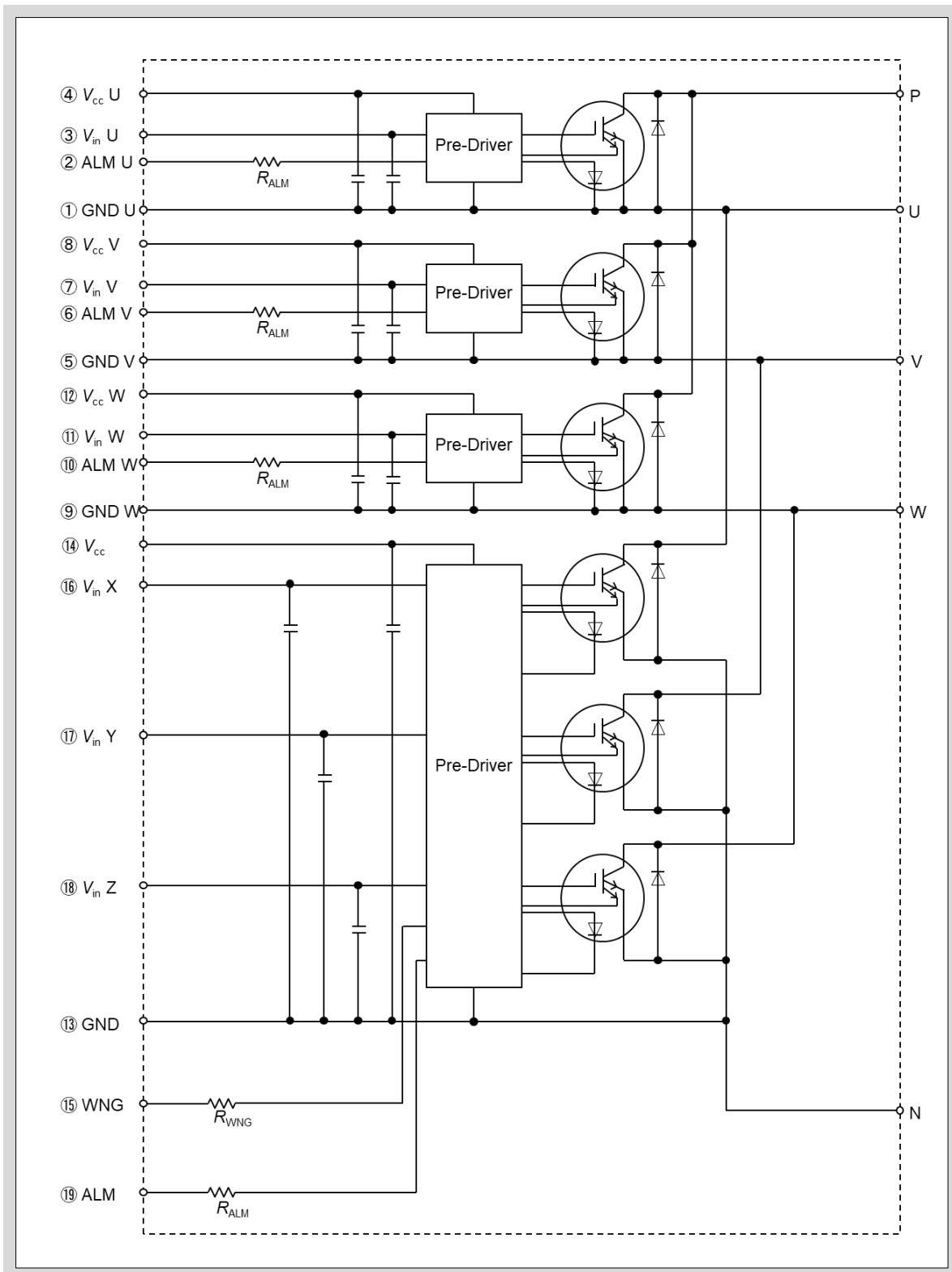

Fig. 3-4 IPM block diagram (example: P630 (6in1))

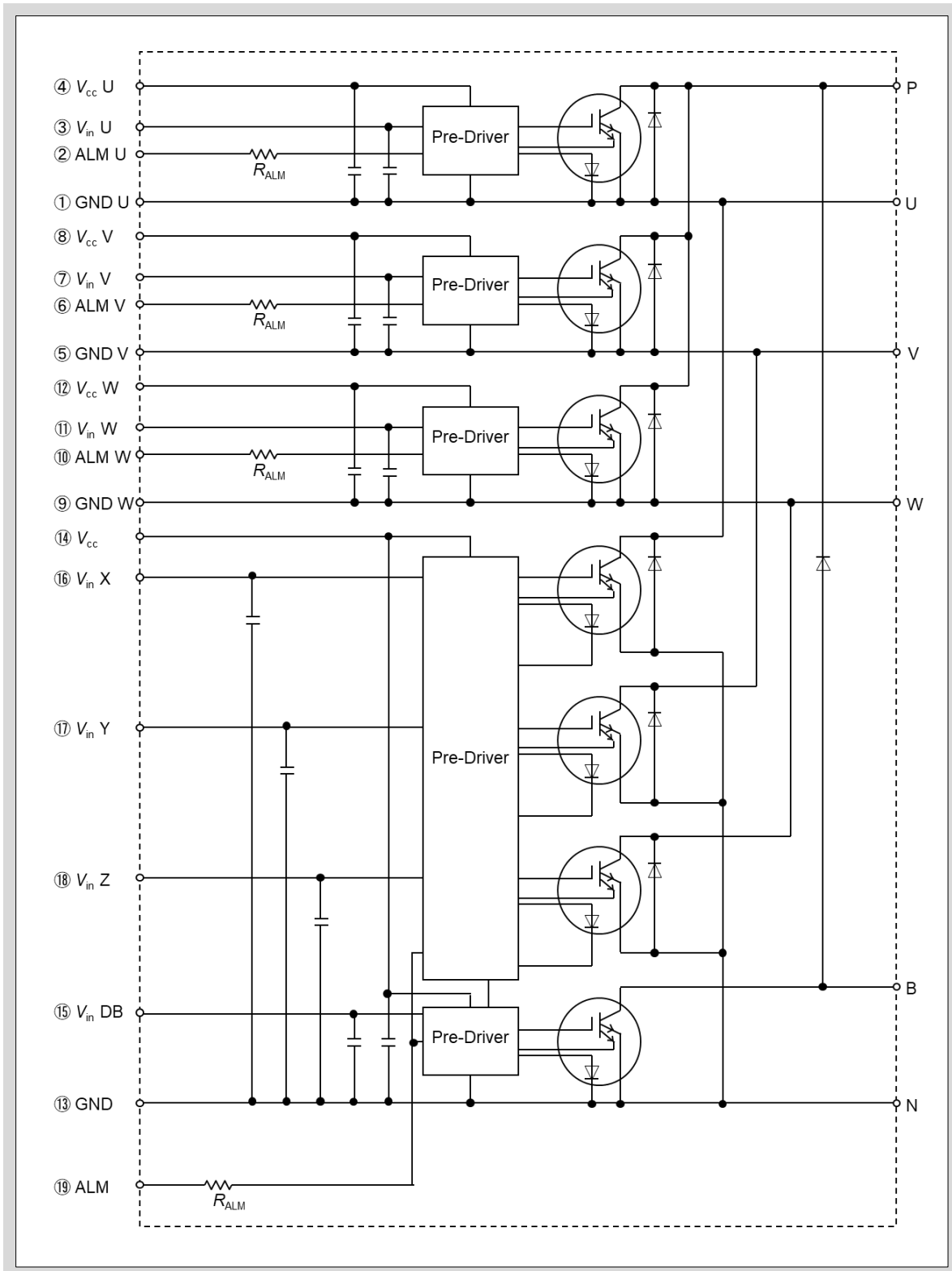

Fig. 3-5 IPM block diagram (example: P630 (7in1))

## 5. Timing chart

### 5.1 Control power supply under voltage protection (UV)

#### 5.1.1 Operation when $V_{CC}$ is turned on and $V_{in}$ is High (OFF). (operation (1)~(4))

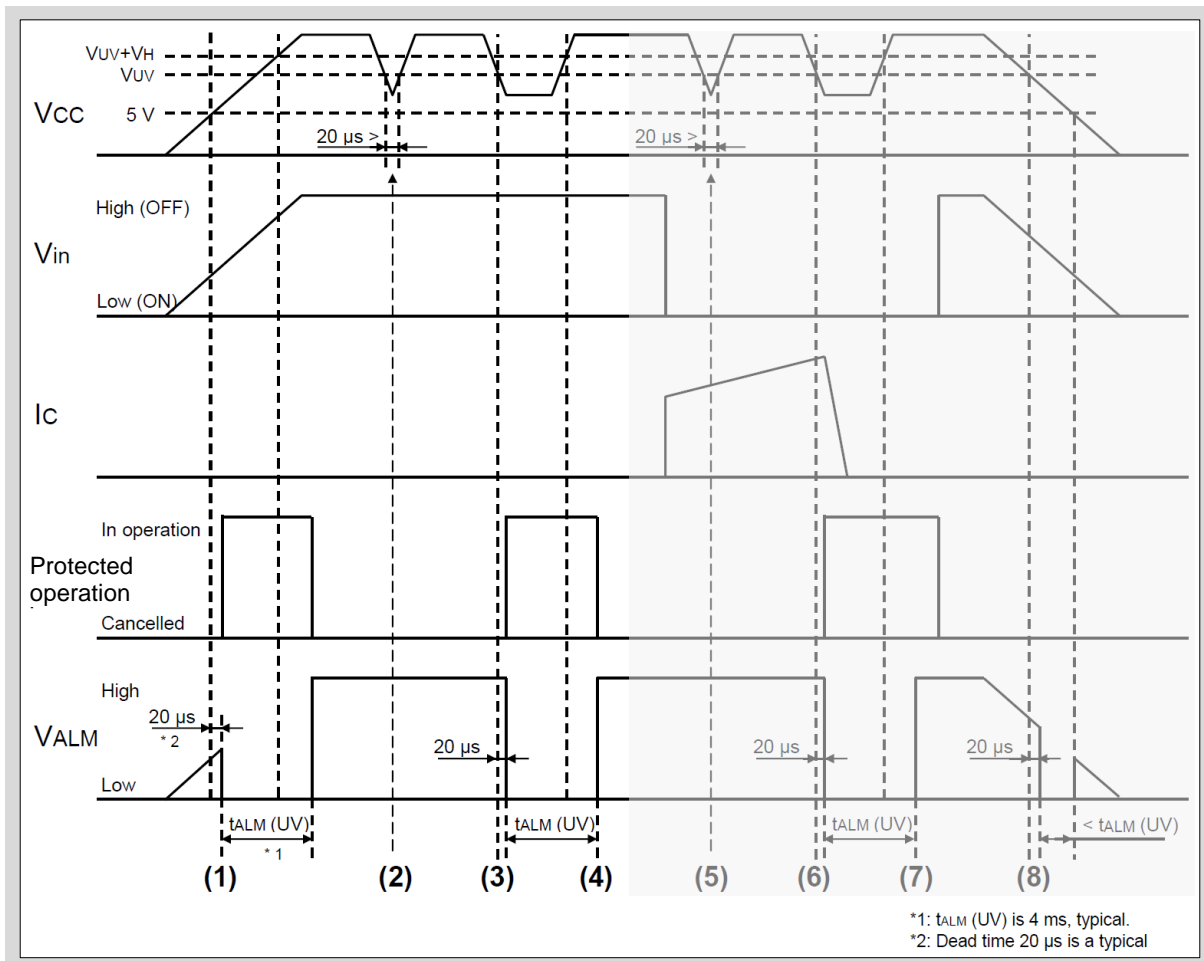

Fig. 3-6 UV protection operation ((1)~(4))

- During  $V_{CC}$  startup, an alarm signal is output when  $V_{CC}$  exceeds 5V and becomes lower than  $V_{UV}$ . (1)  
The protection is not activated regardless of whether the  $V_{in}$  signal is in ON/OFF state if the period during which  $V_{CC}$  is lower than  $V_{UV}$  is shorter than  $20\ \mu s$ . (2)
- The alarm signal is output about  $20\ \mu s$  after  $V_{CC}$  drops below  $V_{UV}$ .  
While  $V_{in}$  is OFF, the IGBT is kept in the OFF-state. (3)
- UV protection operation continues during the  $t_{ALM(UV)}$  period if  $V_{CC}$  returns to  $V_{UV} + V_H$  before  $t_{ALM(UV)}$  elapses. (3)~(4)  
When  $V_{in}$  is OFF, normal operation is resumed after  $t_{ALM(UV)}$  has elapsed. (4)
- Even if the protection operating duration is sufficiently longer than  $t_{ALM(UV)}$ , the alarm signal is output only once.

$V_{CC}$  : Supply voltage of pre-driver  
 $V_H$  : Under voltage protection hysteresis  
 $V_{ALM}$  : Alarm signal voltage

$V_{UV}$  : Under voltage protection level  
 $V_{in}$  : Input signal voltage  
 $t_{ALM(UV)}$  : Alarm signal hold time

5.1.2 Operation when  $V_{in}$  is Low (ON) and  $V_{CC}$  is shut off. (operation (5)~(8))  
Protection operation recovery (4) ~  $V_{CC}$  power off period.

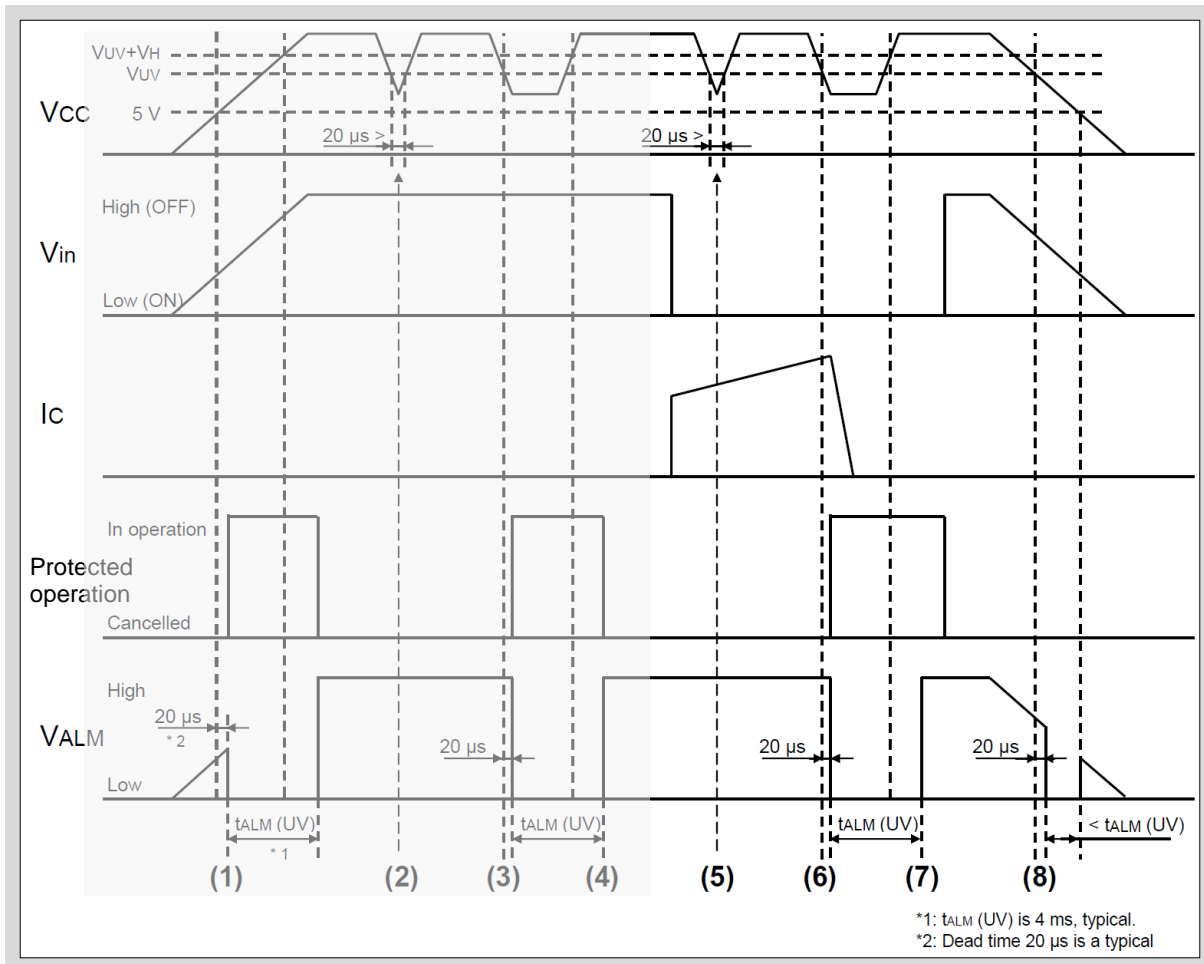

Fig. 3-7 UV protection operation ((5)~(8))

- The protection is not activated regardless of whether the  $V_{in}$  signal is ON/OFF-state if the period during which  $V_{CC}$  is lower than  $V_{UV}$  is shorter than 20 $\mu$ s. (5)
- The alarm signal is output about 20 $\mu$ s after  $V_{CC}$  drops below  $V_{UV}$ .  
While  $V_{in}$  is in ON, the alarm signal is output about 20 $\mu$ s after  $V_{CC}$  drops below  $V_{UV}$ , and the IGBT is turned off softly  $\times 1$ . (6)
- In case  $V_{in}$  remains ON, the alarm signal is output for the  $t_{ALM(UV)}$  period, but the protection function continues operating after that.  
When  $V_{in}$  is in OFF, normal operation is resumed. (7)
- During  $V_{CC}$  shut off, the alarm signal is output when  $V_{CC}$  drops below  $V_{UV}$ . (8)
- Even if the protection operating duration is sufficiently longer than  $t_{ALM(UV)}$ , the alarm signal is output only once.

$\times 1$  Soft turn off : This means a slower than normal turn-off.

$V_{CC}$  : Supply voltage of pre-driver  
 $V_H$  : Under voltage protection hysteresis  
 $V_{ALM}$  : Alarm signal voltage

$V_{UV}$  : Under voltage protection level  
 $V_{in}$  : Input signal voltage  
 $t_{ALM(UV)}$  : Alarm signal hold time



## 5.2 Control power supply under voltage protection (UV) during startup and shutdown of power supply

The X-IPM has control power supply under voltage protection (UV) function. Because of this function, an alarm signal is output during the startup and shutdown of the power supply.

### 5.2.1 During start up

When  $V_{CC}$  exceeds 5V, an alarm signal is output after the elapse of 20 $\mu$ s in both Case 1 (when the inclination of  $V_{CC}$  is fast) and Case 2 (when the inclination of  $V_{CC}$  is slow).

In Case 1,  $V_{CC}$  exceeds  $V_{UV} + V_H$  and  $V_{in}$  becomes OFF-state before  $t_{ALM(UV)}$  elapses, thus the protection operation is stopped after the elapse of  $t_{ALM(UV)}$ .

In Case 2, the protection operation continues even after the elapse of  $t_{ALM(UV)}$  because  $V_{CC}$  is still below  $V_{UV} + V_H$ . The protection operation is stopped when  $V_{CC}$  exceeds  $V_{UV} + V_H$  and  $V_{in}$  is in OFF-state.

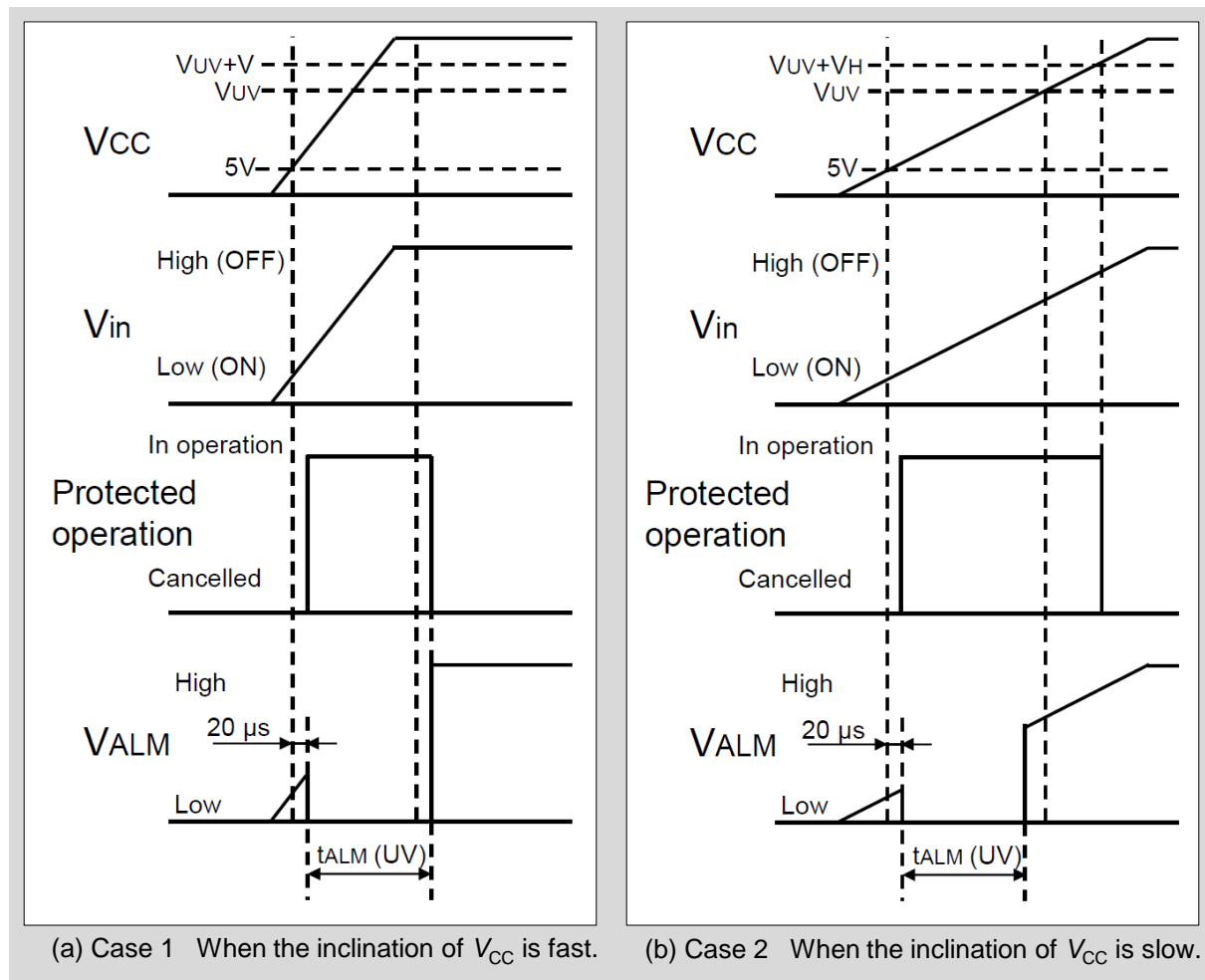

Fig.3-8  $V_{CC}$  start up operation

$V_{CC}$  : Supply voltage of pre-driver  
 $V_H$  : Under voltage protection hysteresis  
 $V_{ALM}$  : Alarm signal voltage

$V_{UV}$  : Under voltage protection level  
 $V_{in}$  : Input signal voltage  
 $t_{ALM(UV)}$  : Alarm signal hold time

### 5.2.2 During Shutdown

When  $V_{CC}$  falls below  $V_{UV}$ , an alarm signal is output after the elapse of  $20\mu s$  in both Case 3 (when the inclination of  $V_{CC}$  is fast) and Case 4 (when the inclination of  $V_{CC}$  is slow).

In Case 3, the alarm signal output is stopped before the elapse of  $t_{ALM(UV)}$  because  $V_{CC}$  falls below 5V and the control IC does not operate normally.

In Case 4, the protection operation continues after the elapse of  $t_{ALM(UV)}$  because  $V_{CC}$  still exceeds 5V. However, when  $V_{CC}$  falls below 5V, the control IC does not operate normally and  $V_{ALM}$  changes to  $V_{CC}$  equivalent.

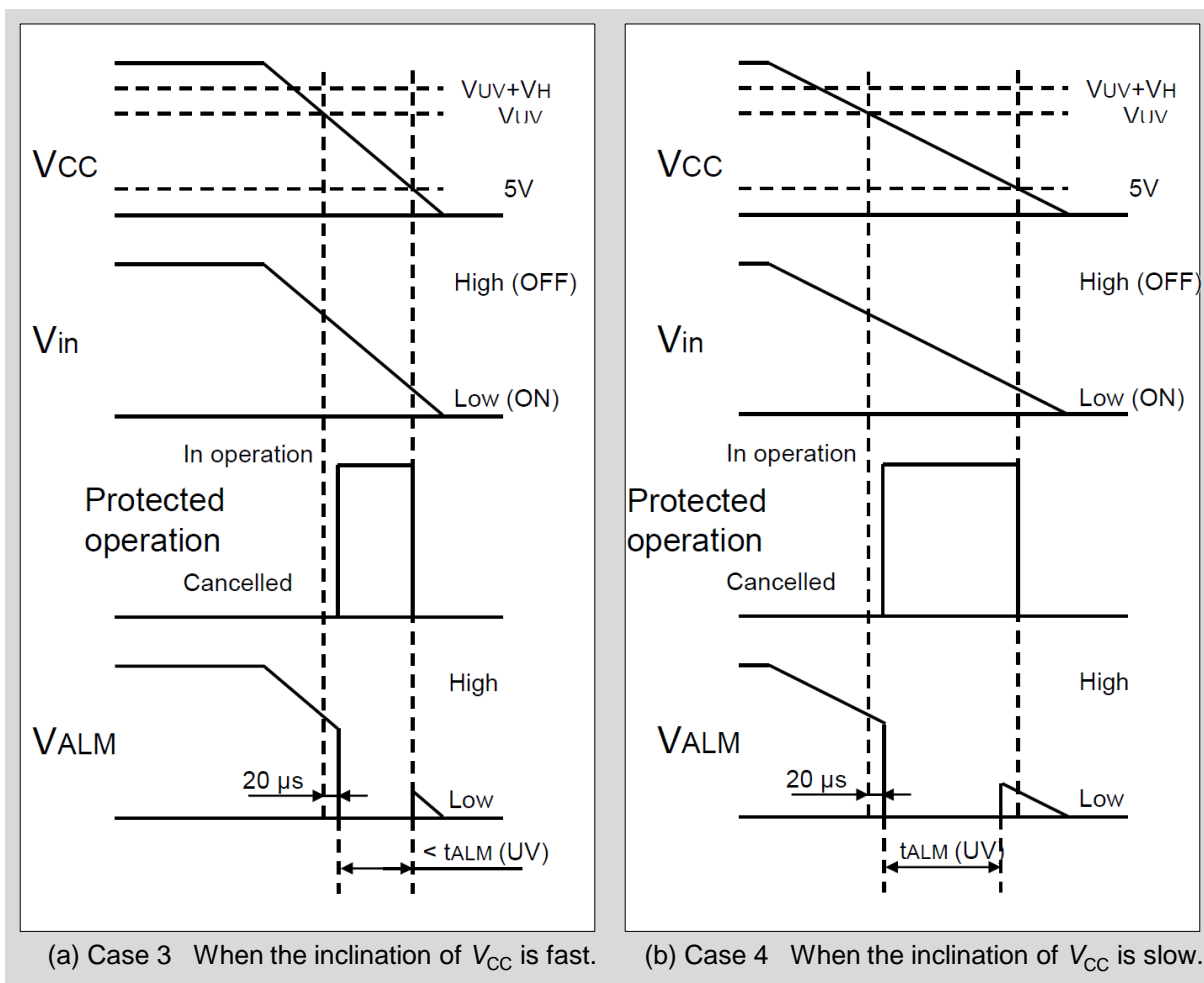

Fig.3-9  $V_{CC}$  shutdown operation

$V_{CC}$  : Supply voltage of pre-driver  
 $V_H$  : Under voltage protection hysteresis  
 $V_{ALM}$  : Alarm signal voltage

$V_{UV}$  : Under voltage protection level  
 $V_{in}$  : Input signal voltage  
 $t_{ALM(UV)}$  : Alarm signal hold time

### 5.3 Multiple alarm signal output from lower arm during control power supply under voltage protection (UV)

Some X series IPM have multiple independent control ICs on the lower arm. These alarm signal outputs are a common output on the lower arm. Therefore, there are some cases when several alarm are output because of the variation in the under voltage protection level of the control ICs. If  $dv/dt$  of  $V_{UV}$  is less than 0.5V/ms in the vicinity of  $V_{CC}$ , there is possibility of alarm output such as shown in Figure 3-10. (This is not an abnormal phenomenon.)

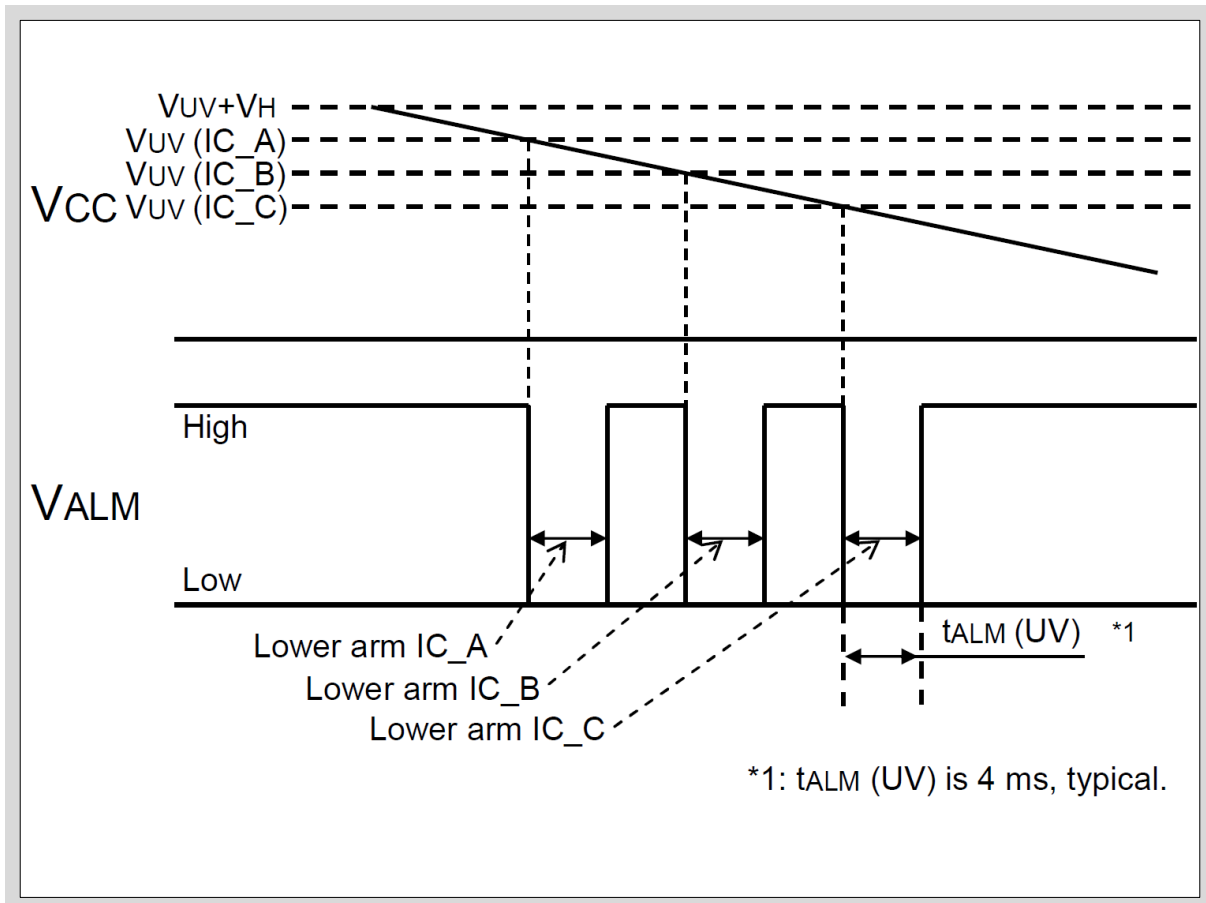

Fig.3-10 UV alarm output of lower arm

$V_{CC}$  : Supply voltage of pre-driver  
 $V_{ALM}$  : Alarm signal voltage

$V_{UV}$  : Under voltage protection level  
 $t_{ALM(UV)}$ : Alarm signal hold time

#### 5.4 Over current protection (OC) operation

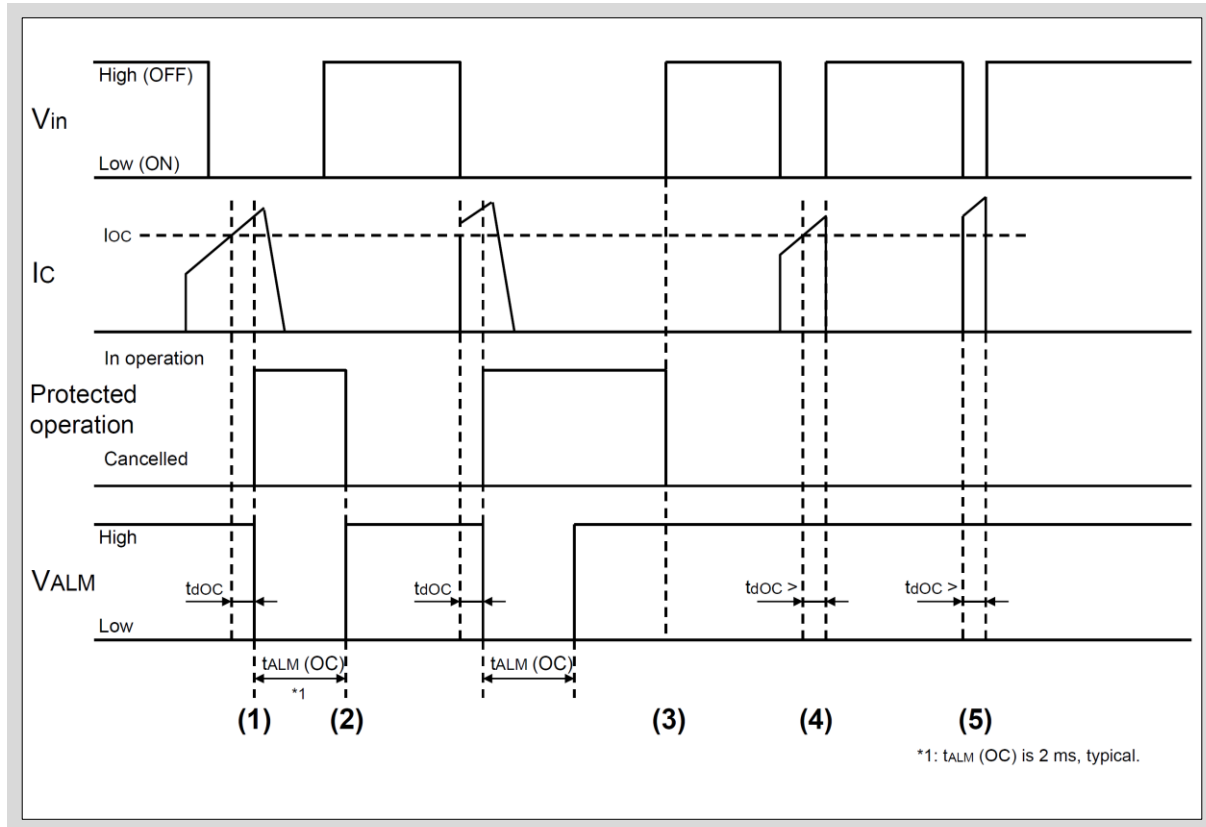

Fig.3-11 OC protection operation

- When  $I_C$  exceeds the over current protection level  $I_{OC}$ , an alarm signal is output after the elapse of  $t_{dOC}$ , and the IGBT is turned off softly  $\times 1$ . (1)
- The protection operation continues during the period of  $t_{ALM(OC)}$  even if  $V_{in}$  is in OFF-state, and resumes to normal operation after the elapse of  $t_{ALM(OC)}$  if  $V_{in}$  becomes OFF-state. (2)
- The protection operation continues if  $V_{in}$  is in ON-state after the elapse of  $t_{ALM(OC)}$ , and resumes to normal operation if the  $V_{in}$  becomes OFF-state. (3)
- If  $V_{in}$  is in OFF-state before the elapse of  $t_{dOC}$  after  $I_C$  exceeds  $I_{OC}$ , the protection operation is not activated and the IGBT is turned off normally  $\times 2$ . (4)
- Even if  $I_C$  exceeds  $I_{OC}$  when  $V_{in}$  is in ON-state, if  $V_{in}$  becomes OFF-state before the elapse of  $t_{dOC}$ , the protection operation is not activated and the IGBT is turned-off normally. (5)
- Even if the protection operating duration is sufficiently longer than  $t_{ALM(OC)}$ , the alarm signal is output only once.

$\times 1$  Soft turn off: This means a slower than normal turn-off.

$\times 2$  Normal turn off: This means a normal turn-off operation.

$V_{in}$  : Input signal voltage

$I_C$  : Collector current

$t_{ALM(OC)}$ : Alarm signal hold time

$V_{ALM}$  : Alarm signal voltage

$I_{OC}$  : Over current protection level

$t_{dOC}$  : Over current protection delay time

### 5.5 Short circuit protection (SC) operation

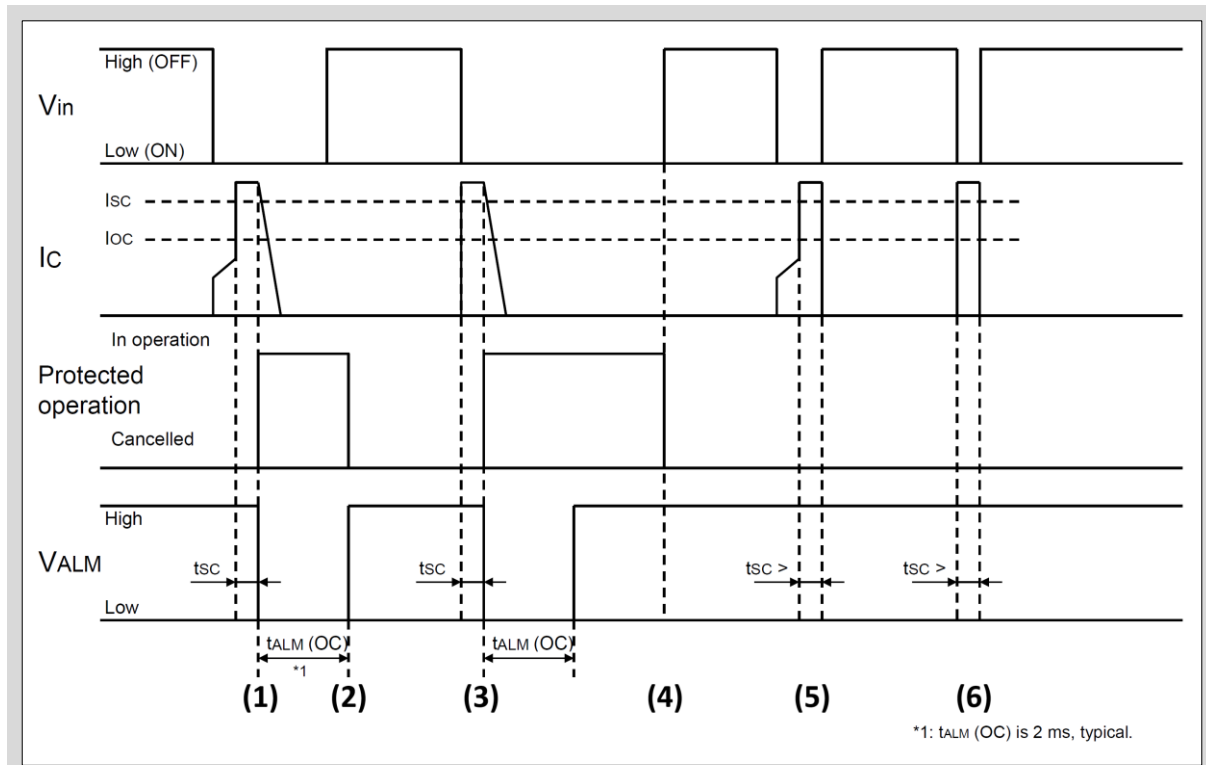

Fig.3-12 SC protection operation

- If a load short circuit occurs after  $I_c$  is flowing and  $I_c$  exceeds  $I_{SC}$ , the peak current of  $I_c$  is suppressed momentarily. After the elapse of  $t_{SC}$ , an alarm signal is output and the IGBT is turned off softly <sup>※1</sup>. (1)
- The SC protection operation is stopped if  $V_{in}$  is in OFF-state after the elapse of  $t_{ALM(OC)}$ . (2)
- If a load short-circuit occurs as soon as  $I_c$  began to flow and  $I_c$  exceeds  $I_{SC}$ , the peak current is suppressed momentarily. After the elapse of  $t_{SC}$ , the alarm signal is output and the IGBT is turned off softly. (3)
- The SC protection operation continues even after the elapse of  $t_{ALM(OC)}$  if  $V_{in}$  is in ON-state. The SC protection operation is stopped when  $V_{in}$  becomes OFF-state. Even if the protection operating duration is sufficiently longer than  $t_{ALM(OC)}$ , the alarm signal is output only once. (4)
- If a load short-circuit occurs after  $I_c$  began to flow, the peak current of  $I_c$  is suppressed momentarily as soon as the  $I_c$  exceeds  $I_{SC}$ . After that, if  $V_{in}$  becomes OFF-state before the elapse of  $t_{SC}$ , the SC protection operation is not activated and the IGBT is turned off normally <sup>※2</sup>. (5)
- If a load short-circuit occurs as soon as  $I_c$  began to flow and  $I_c$  exceeds  $I_{SC}$ ,  $I_c$  peak is suppressed momentarily. If  $V_{in}$  becomes OFF-state before the elapse of  $t_{SC}$ , the SC protection operation is not activated and the IGBT is turned off normally. (6)

※1 Soft turn off: This means a slower than normal turn-off.

※2 Normal turn off: This means a normal turn-off operation.

$V_{in}$  : Input Signal Voltage

$I_c$  : Collector current

$t_{ALM(OC)}$ : Alarm signal hold time

$I_{SC}$  : SC trip level

$t_{SC}$  : Short circuit protection delay time

### 5.6 IGBT chips over heating protection ( $T_{jOH}$ ) operation

: When the ON/OFF state of  $V_{in}$  affects the protection operation

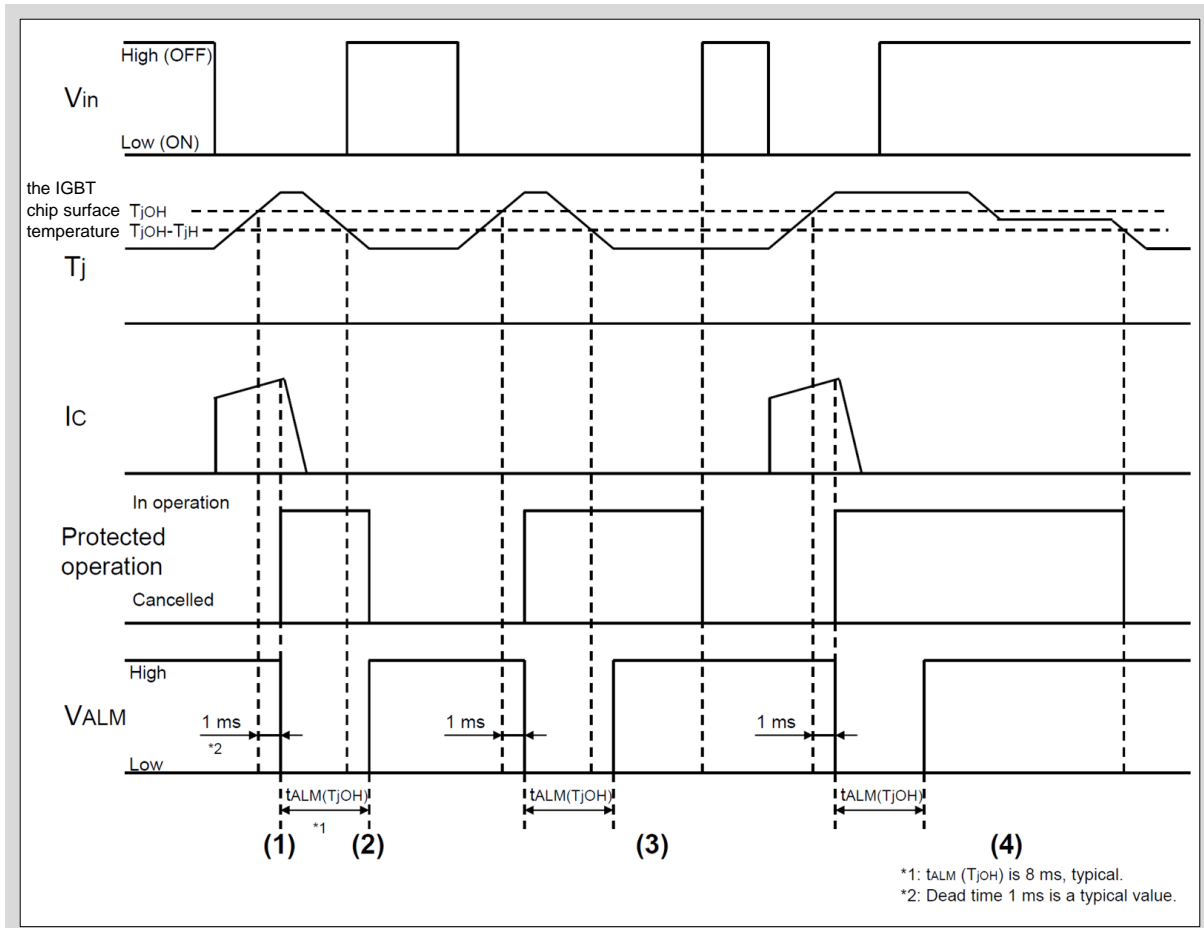

Fig.3-13  $T_{jOH}$  protection operation (1)

- If the IGBT chip surface temperature  $T_{vj}$  is higher than  $T_{jOH}$  continuously for a period exceeding 1 ms, an alarm signal is output and the IGBT is turned off softly ※1. (1)
- The protection operation continues during the period of  $t_{ALM(TjOH)}$  even if  $T_{vj}$  drops below  $T_{jOH} - T_{jH}$  before the elapse of  $t_{ALM(TjOH)}$ . Normal operation resumes if  $V_{in}$  is in OFF-state after the elapse of  $t_{ALM(TjOH)}$ . (2)
- The protection operation continues if  $V_{in}$  is in ON-state, even if  $T_{vj}$  drops below  $T_{jOH} - T_{jH}$  after the elapse of  $t_{ALM(TjOH)}$ . (3)
- The protection operation continues after the elapse of  $t_{ALM(TjOH)}$  even when  $V_{in}$  is in OFF-state if  $T_{vj}$  exceeds  $T_{jOH} - T_{jH}$ . Even if the protection operating duration is sufficiently longer than  $t_{ALM(TjOH)}$ , the alarm signal is output only once. (4)

※1 Soft turn off: This means a slower than normal turn-off.

$V_{in}$  : Input signal voltage  
 $V_{ALM}$  : Alarm signal voltage  
 $t_{ALM(TjOH)}$  : Alarm signal hold time  
 $T_{jOH}$  : IGBT chips over heating protection temperature level  
 $T_{jH}$  : Over heating protection hysteresis

### 5.7 IGBT chips over heating protection ( $T_{jOH}$ ) operation

: When the ON/OFF state of  $V_{in}$  does not affect the protection operation

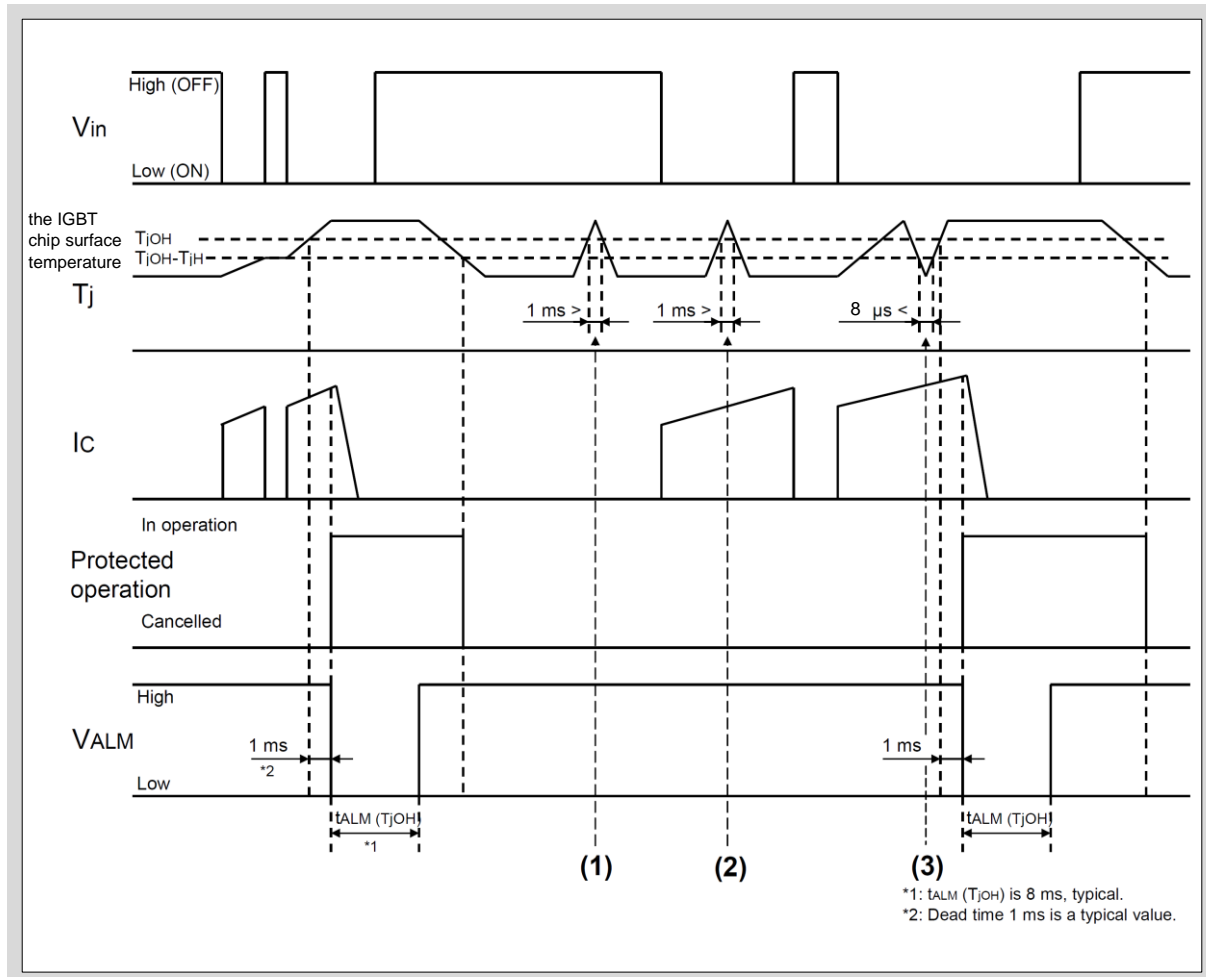

Fig.3-14  $T_{jOH}$  protection operation (2)

- The protection operation is not activated if the IGBT chip surface temperature  $T_{vj}$  exceeds and drops below  $T_{jOH}$  within 1ms, regardless of whether  $V_{in}$  is in ON or OFF. (1),(2)
- If  $T_{vj}$  drops below  $T_{jOH} - T_{jH}$  for longer than  $8\mu s$  after  $T_{vj}$  exceeds  $T_{jOH}$ , the  $T_{jOH}$  detection timer of which duration is approximately 1ms is reset. (3)

$V_{in}$  : Input signal voltage

$V_{ALM}$  : Alarm signal voltage

$I_C$  : Collector current

$t_{ALM(TjOH)}$  : Alarm signal hold time

$T_{jOH}$  : IGBT chips over heating protection temperature level

$T_{jH}$  : Over heating protection hysteresis

### 5.7 Control power supply under voltage protection (UV) operation during IGBT chips over heating protection ( $T_{jOH}$ ) operation (1)~(3)

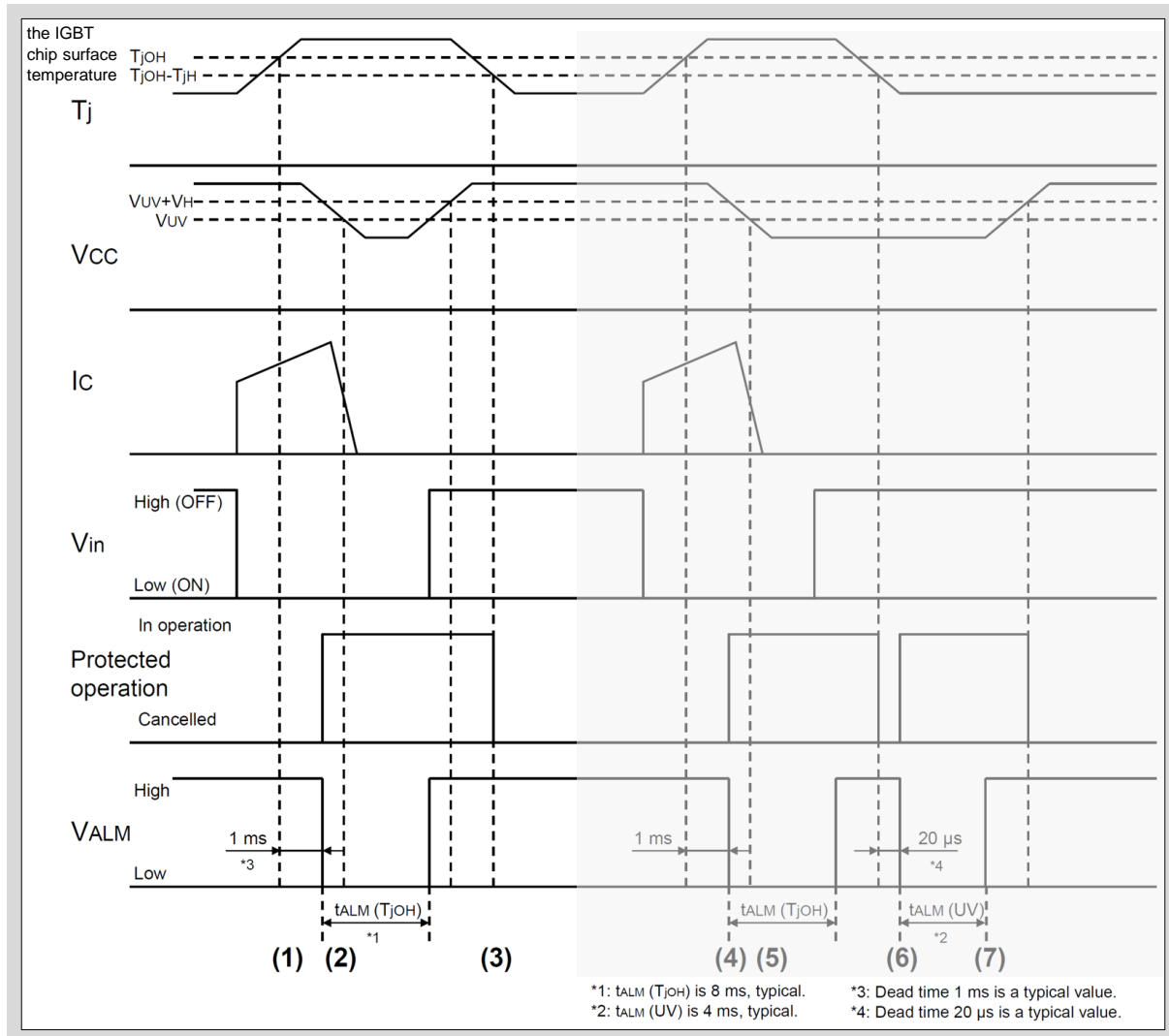

Fig.3-15  $T_{jOH}$  combined protection operation (1)~(3)

- When the IGBT chip surface temperature  $T_{vj}$  exceeds  $T_{jOH}$  for 1ms continuously, an alarm signal is output and the IGBT is turned off softly ※1. (1)
- If  $V_{CC}$  drops below  $V_{UV}$  before the elapse of  $t_{ALM}(T_{jOH})$ , the alarm signal output by UV protection is cancelled because the protection operation of  $t_{ALM}(T_{jOH})$  continues. (2)
- The protection operation is reset after the elapse of  $t_{ALM}(T_{jOH})$  if  $V_{in}$  is in OFF-state and  $T_{vj}$  drops below  $T_{jOH} - T_{jH}$ . (3)

※1 Soft turn off: This means a slower than normal turn-off.

$V_{CC}$	: Supply voltage of pre-driver	$V_{UV}$	: Under voltage protection level
$V_{in}$	: Input signal voltage	$V_{ALM}$	: Alarm signal voltage
$I_C$	: Collector current	$t_{ALM(UV)}$	: Alarm signal hold time
$t_{ALM}(T_{jOH})$	: Alarm signal hold time		
$T_{jOH}$	: IGBT chips over heating protection temperature level		
$T_{jH}$	: Over heating protection hysteresis		



### 5.8 Control power supply under voltage protection (UV) operation after IGBT chips over heating protection ( $T_{jOH}$ ) operation ends (4)~(7)

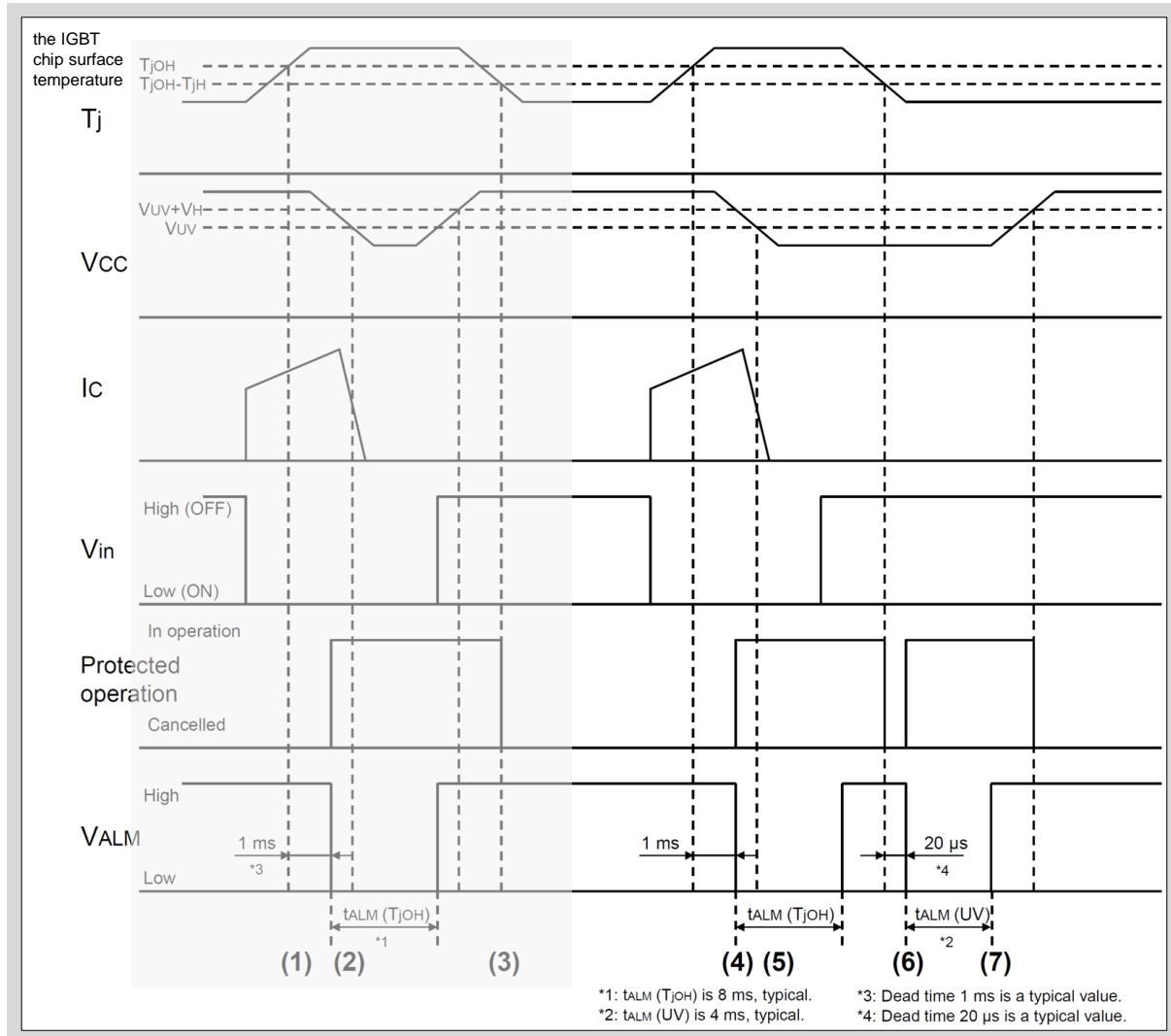

Fig.3-16  $T_{jOH}$  combined protection operation (4)~(7)

- When the IGBT chip surface temperature  $T_{vj}$  exceeds  $T_{jOH}$  for 1ms continuously, an alarm signal is output and the IGBT is turned off softly ※1. (4)
- Similar to (2), the alarm signal output by UV protection is cancelled while the protection operation of  $t_{ALM(TjOH)}$  continues. (5)
- The protection operation is reset after the elapse of  $t_{ALM(TjOH)}$  if  $V_{in}$  is in OFF-state and  $T_{vj}$  drops below  $T_{jOH} - T_{jH}$ . After this, if  $V_{CC}$  drops below  $V_{UV}$  continuously for 20 $\mu s$ , UV protection is activated and the alarm signal is output. (6)
- The protection operation is stopped after the elapse of  $t_{ALM(UV)}$  if  $V_{in}$  is in OFF-state and  $V_{CC}$  exceeds  $V_{UV} + V_H$ . (7)

※1 Soft turn off: This means a slower than normal turn-off.

$t_{ALM(TjOH)}$  : Alarm signal hold time                       $t_{ALM(UV)}$  : Alarm signal hold time  
 $T_{jOH}$  : IGBT chips over heating protection temperature level  
 $T_{jH}$  : Over heating protection hysteresis

### 5.9 IGBT chip temperature warning output operation

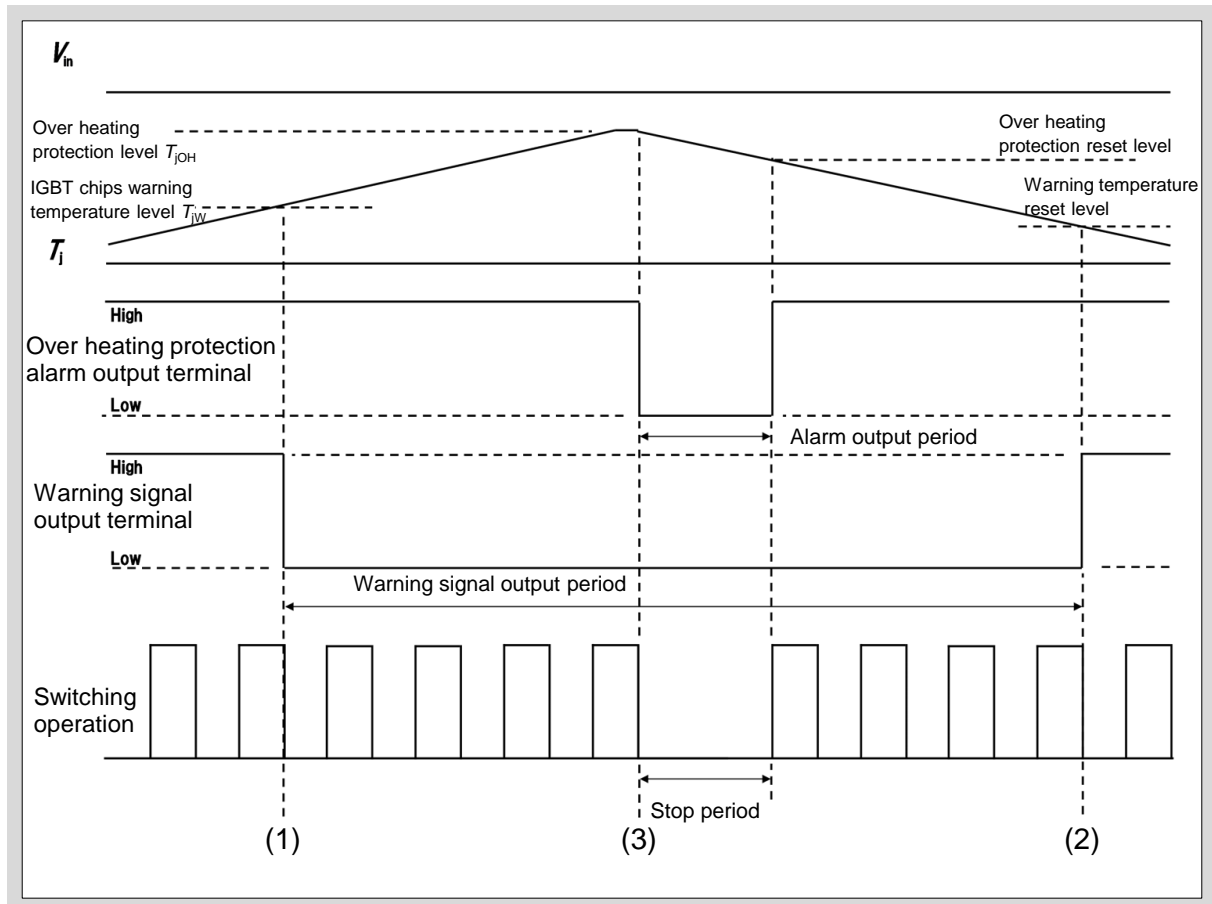

Fig.3-17 Chip temperature warning operation

- A chip temperature warning signal is output before the switching operation is stopped by IGBT chips over heating protection. During this time, the switching operation continues.
- When the IGBT chip surface temperature  $T_{vj}$  reaches the IGBT chips warning temperature level  $T_{jW}$ , the  $T_{vj}$  warning signal output terminal voltage changes from  $V_{CC}$  to 0V. During this time, the switching operation continues. (1)
- When  $T_{vj}$  falls below  $T_{jW}$ , the  $T_{vj}$  warning signal output terminal voltage returns to  $V_{CC}$ . (2)
- Next, if  $T_{vj}$  exceeds  $T_{jOH}$  in the state of (1), an alarm signal is output and the switching operation is stopped. (3)

$V_{CC}$  : Supply voltage of pre-driver

$T_{jOH}$  : IGBT chips over heating protection temperature level