

Fuji IGBT Modules for Solar Inverter



Device Application Technology Dept.
Sales Div.
Electronic Devices Business Group

- Topology in solar inverter
- Fuji IGBT modules for solar inverter
- Fuji solution in Gate Driver Unit (GDU)
- Fuji 2 level topology solution
- Fuji 3 level topology solution - Stack

Example of Solar Inverter Schematic

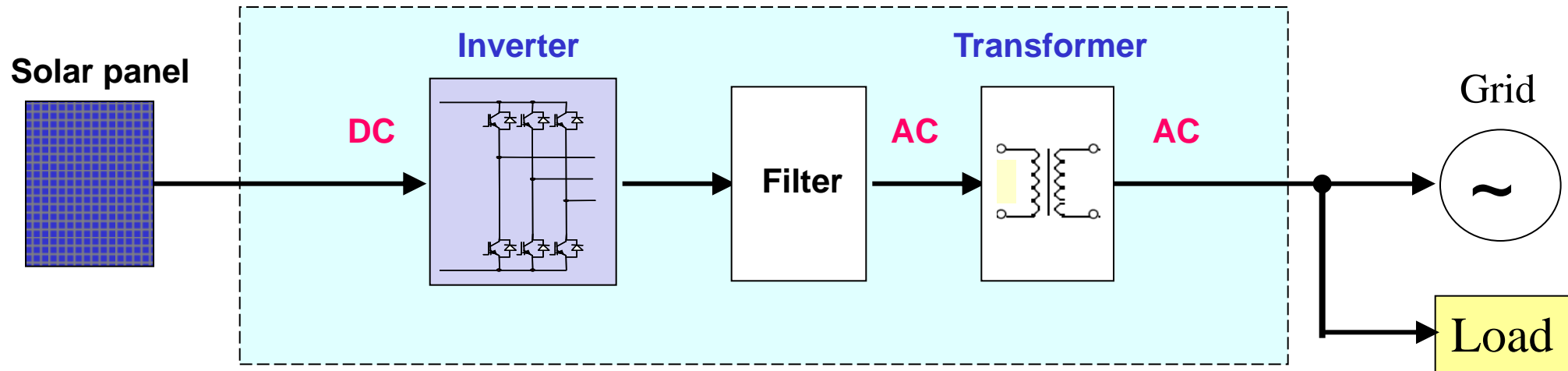

■ **Feature of solar inverter: High efficiency, High reliability.**

	General inverter	Solar inverter
Input voltage	AC (Ex. 400V ± 10%)	DC 400 ~ 1000V
Output frequency	Ex. 0.5 ~ 120Hz	50 / 60Hz
Efficiency	90 ~ 95%	> 95%
Overload	150 ~ 200%	100 ~ 120%
Device (ex. 30kW)	1200V / 150A	1200V / 200A

Topology in Solar Inverter

Type	Single-phase inverter	2-level inverter	NPC 3-level inverter	A-NPC 3-level with RB-IGBT
Circuit				
Device	IGBT:600V	IGBT:1200V	IGBT:600V	IGBT:1200V +600V(RB-IGBT)
Output Voltage				
Capacity	< 10kW	> 10kW	> 10kW	> 10kW

- Topology in solar inverter
- **Fuji IGBT modules for solar inverter**
- Fuji solution in Gate Driver Unit (GDU)
- Fuji 2 level topology solution
- Fuji 3 level topology solution - Stack

Fuji IGBT Module for Solar Inverter (2-level)

Standard 1in1/2in1

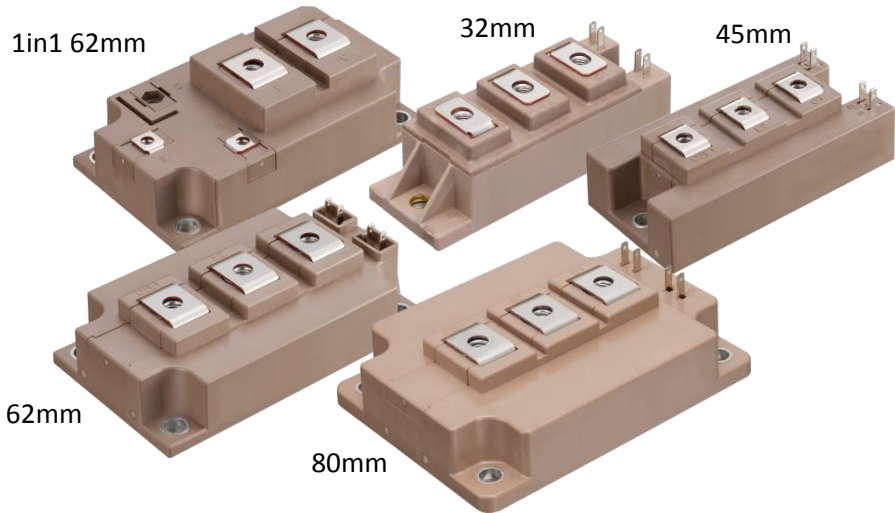

Dual XT

M254
150 x 62 x 17mm

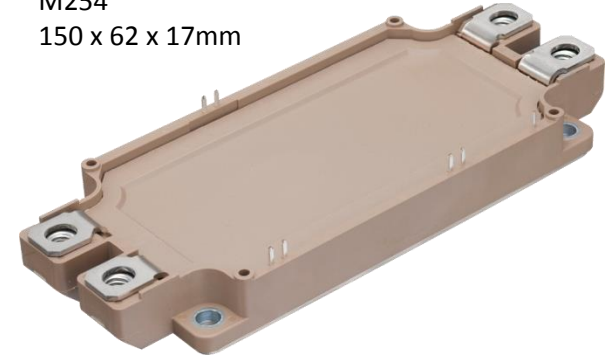

PrimePACK™

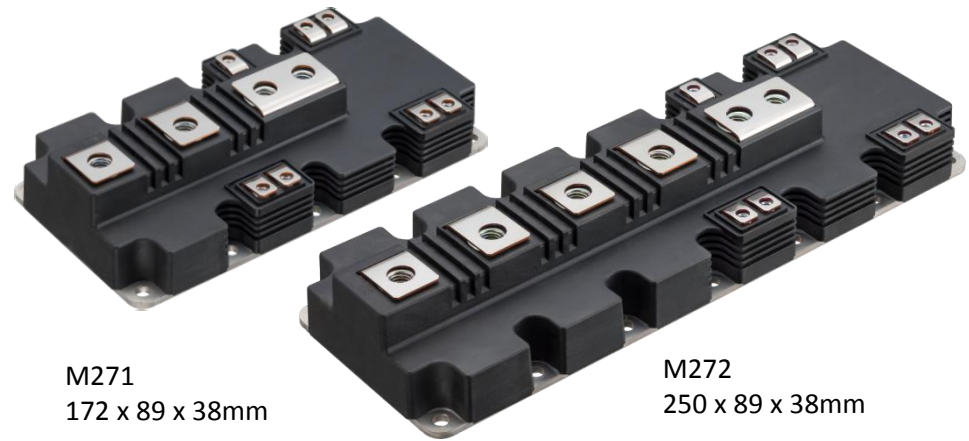

EconoPACK™+

M629
150 x 162 x 17mm

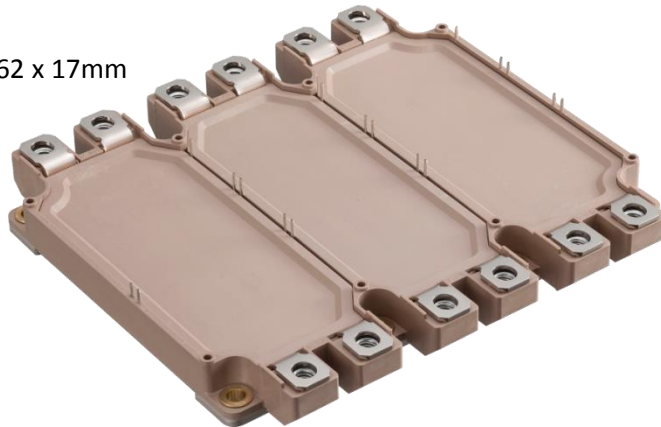

Note: EconoPACK™+ and PrimePACK™ are registered trademarks of Infineon Technology AG, Germany.

2-level Topology (Condition: $V_{DC(\text{rating})} = 450\text{V}$, $V_{DC(\text{max})} = 850\text{V}$)

PCS	VCES	Ic rating	IGBT P/N	Number of parallel
10kW	1200V	75A	2MBI75VA-120-50	1
15kW	1200V	100A	2MBI100VA-120-50	1
20kW	1200V	150A	2MBI150VA-120-50	1
			2MBI150VB-120-50	
30kW	1200V	200A	2MBI200VB-120-50	1
			2MBI200VH-120-50	
		225A	6MBI225V-120-50	1
50kW	1200V	300A	2MBI300VD-120-50	1
			2MBI300VH-120-50	
			2MBI300VE-120-50	
			2MBI300VN-120-50	
			2MBI300VJ-120-50	
			6MBI300V-120-50	
100kW	1200V	450A	2MBI450VH-120-50	1
			2MBI450VE-120-50	
			2MBI450VN-120-50	
			2MBI450VJ-120-50	
			6MBI450V-120-50	
125kW	1200V	600A	2MBI600VE-120-50	1
			2MBI600VN-120-50	
			2MBI600VJ-120-50	
			2MBI600VG-120-50	
			2MBI600VXA-120E-50	
250kW	1200V	1400A	2MBI1400VXB-120E-50	1
			2MBI1400VXB-120P-50	
500kW	1200V	1400A x2p	2MBI1400VXB-120E-50	2
			2MBI1400VXB-120P-50	
1000kW	1200V	1400A x 4p	2MBI1400VXB-120E-50	4
			2MBI1400VXB-120P-50	





Fuji IGBT Module for Solar Inverter

EconoPACK™+, Dual XT

Note: EconoPACK™+ are registered trademarks of Infineon Technology AG, Germany.

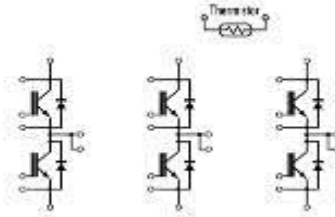
Feature

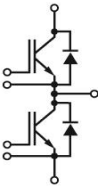

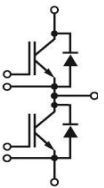

- ✓ Low power dissipation with V-silicon chipset
- ✓ Extra thermal design (Tjmax = 175°C repetitive guarantee)
- ✓ 2 kinds of pin connection for Dual XT (Solder/Spring)

	IGBT P/N	Current	Voltage	Package	Equivalent circuit
EconoPACK™+	6MBI225V-120-50	225A	1200V	M629:150 x 162 x 17mm 	
	6MBI300V-120-50	300A	1200V		
	6MBI450V-120-50	450A	1200V		
Dual XT	2MBI300VN-120-50	300A	1200V	M254:150 x 62 x 17mm 	
	2MBI450VN-120-50	450A	1200V		
	2MBI600VN-120-50	600A	1200V		
	2MBI300VJ-120-50	300A	1200V	M260:150 x 62 x 17mm  Spring type	
	2MBI450VJ-120-50	450A	1200V		
	2MBI600VJ-120-50	600A	1200V		

Fuji IGBT Module for Solar Inverter (2in1)

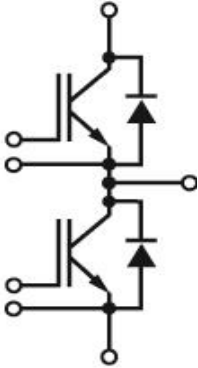
Feature

- ✓ Low power dissipation with V-silicon chipset
- ✓ Extra thermal design (Tjmax = 175°C repetitive guarantee)

	IGBT P/N	Current	Voltage	Package	Equivalent circuit
Standard 2in1	2MBI**VA-120-50	75A, 100A, 150A	1200V	M263 	
	2MBI**VB-120-50	150A, 200A	1200V	M274 	
	2MBI**VD-120-50	300A, 400A	1200V	M275 	
	2MBI**VH-120-50	200A, 300A, 450A	1200V	M276 	
	2MBI**VE-120-50	300A, 450A, 600A	1200V	M277 	

Fuji IGBT Module for Solar Inverter (3-level)

EP3 (12in1)

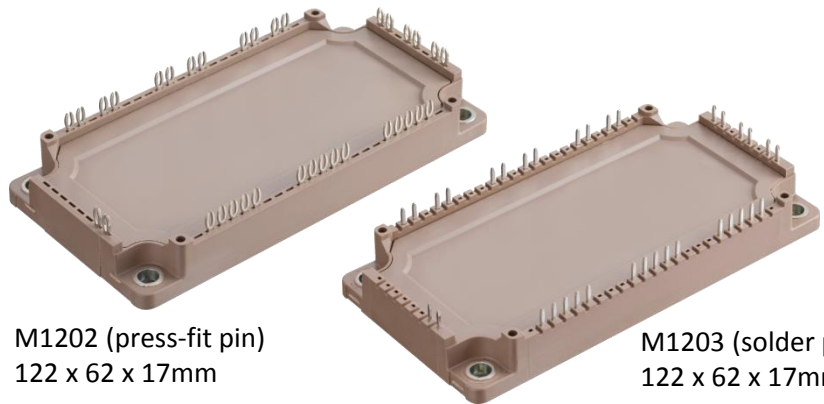

M1202 (press-fit pin)
122 x 62 x 17mm

M1203 (solder pin)
122 x 62 x 17mm

M403 (4in1)

110 x 80 x 30mm

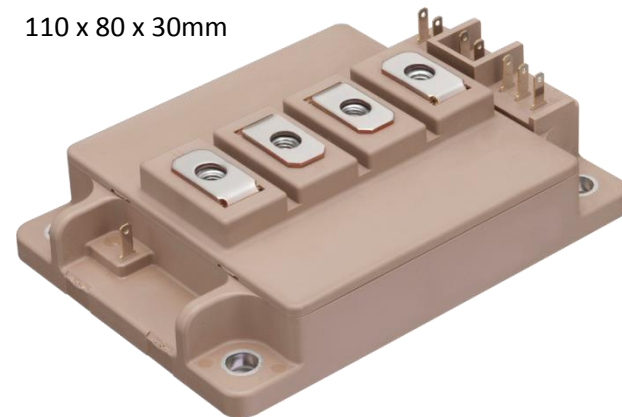

PrimePACK™

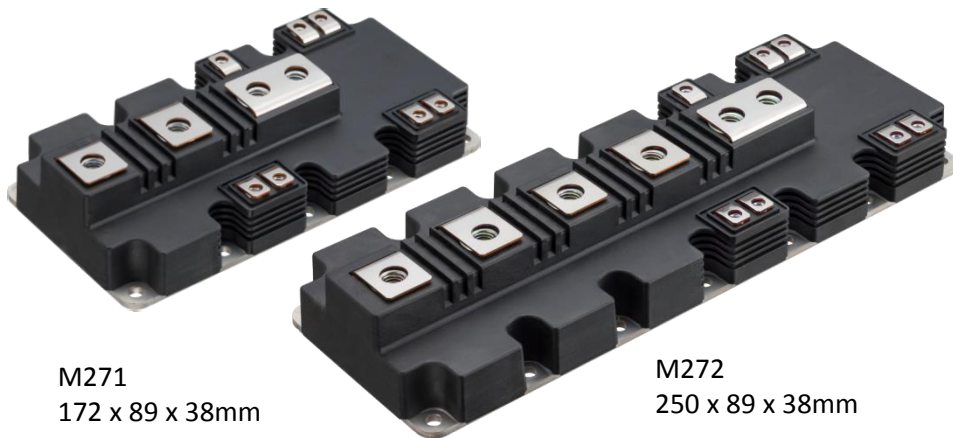

M271
172 x 89 x 38mm

M272
250 x 89 x 38mm

T-Prime (4in1)

M404
250 x 89 x 38mm

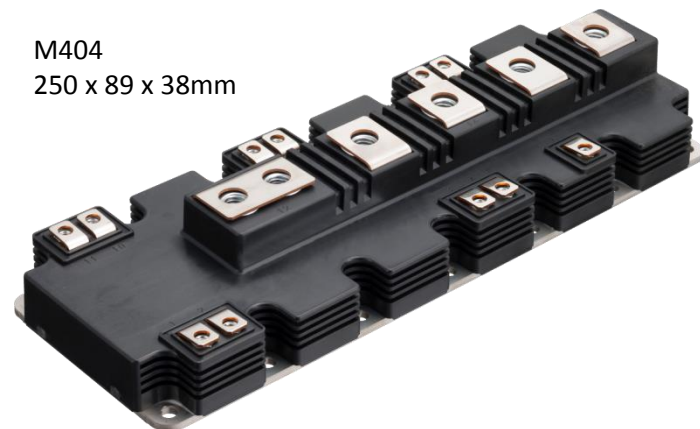

Note: PrimePACK™ is registered trademarks of Infineon Technology AG, Germany.

Advanced T-type 3-level Module

(Condition: $V_{DC(\text{rating})} = 450\text{V}$, $V_{DC(\text{max})} = 850\text{V}$)

PCS	VCES	Ic rating	Package	IGBT P/N	Number of parallel
10kW	1200V	75A	EP3(12in1)	12MBI75VN-120-50	1
				12MBI75VX-120-50	
15kW	1200V	100A	EP3(12in1)	12MBI100VN-120-50	1
				12MBI100VX-120-50	
20kW	1200V	150A	M403(4in1)	4MBI300VG-120R-50	1
30kW	1200V	200A	M403(4in1)	4MBI300VG-120R-50	1
50kW	1200V	300A	M403(4in1)	4MBI300VG-120R-50	1
100kW	1200V	300A x2p	M403(4in1)	4MBI300VG-120R-50	2
		650A	M404(T-Prime)	4MBI650VB-120R1-50	1
125kW	1200V	300A x2p	M403(4in1)	4MBI300VG-120R-50	2
		650A	M404(T-Prime)	4MBI650VB-120R1-50	1
250kW	1200V	300A x4p	M403(4in1)	4MBI300VG-120R-50	4
		900A	M404(T-Prime)	4MBI900VB-120R1-50	1
500kW	1200V	900A x2p	M404(T-Prime)	4MBI900VB-120R1-50	2
1000kW	1200V	900A x4p	M404(T-Prime)	4MBI900VB-120R1-50	4

Notice:

Applicable device might be different by control method, control condition, cooling condition, etc.

Fuji IGBT Module for Solar Inverter

PrimePACK™+

Feature

- ✓ Low power dissipation with V-silicon chipset
- ✓ Extra thermal design (Tjmax=175°C repetitive guarantee)
- ✓ Low inductance and good current balance package
- ✓ Long-term reliability (CTI > 600, High Tc capability)

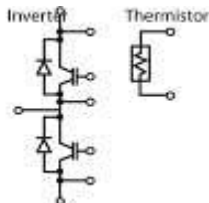
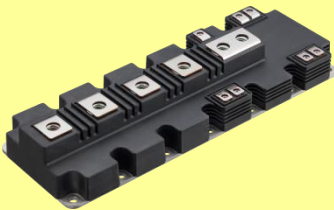
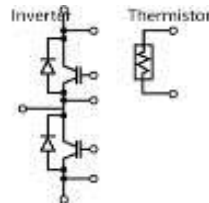
	IGBT part No.	Current	Voltage	Package	Equivalent circuit	Base plate	Isolation
PrimePACK™	2MBI600VXA-120E-50	600A	1200V	M271:172 x 89 x 38mm 		Copper (Cu)	Al ₃ O ₂ Viso=4.0kV/60s
	2MBI900VXA-120E-50	900A	1200V				
	2MBI1400VXB-120P-50	1400A	1200V	M272:250 x 89 x 38mm 		Copper (Cu)	Al ₃ O ₂ Viso=4.0kV/60s

Note: PrimePACK™ are registered trademarks of Infineon Technology AG, Germany.

Fuji IGBT Module for Solar Inverter – EP3 (12in1)

Feature

- ✓ A new RB-IGBT and an existing IGBT are integrated in one package. (Fuji specific technology!)
- ✓ The stray inductance between each main terminals < 40nH
- ✓ The arrangement of the terminals is optimized for construction of A-NPC power converters.

※RB-IGBT: Reverse Blocking-Insulated Gate-Bipolar Transistor

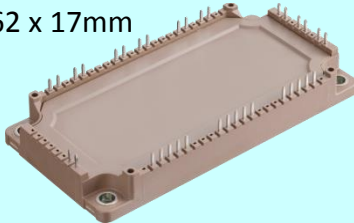
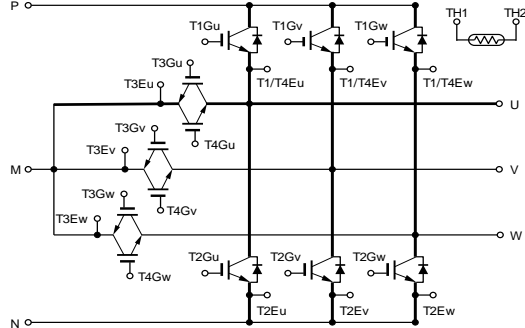
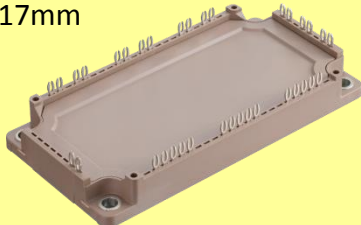
	IGBT part No.	Current	Voltage	Package	Equivalent circuit
EP3(12in1)	12MBI50VN-120-50	50A	1200V	M1203 (solder pin) 122 x 62 x 17mm 	
	12MBI75VN-120-50	75A	1200V		
	12MBI100VN-120-50	100A	1200V		
	12MBI50VX-120-50	50A	1200V	M1202 (press-fit pin) 122 x 62 x 17mm 	
	12MBI75VX-120-50	75A	1200V		
	12MBI100VX-120-50	100A	1200V		

Fuji IGBT Module for Solar Inverter – M403(4in1)

Feature

- ✓ A new RB-IGBT and an existing IGBT are integrated in one package. (Fuji specific technology!)
 - ✓ The stray inductance between each main terminals < 40nH
 - ✓ The arrangement of the terminals is optimized for construction of A-NPC power converters.
- ✕ RB-IGBT: Reverse Blocking Insulated Gate Bipolar Transistor

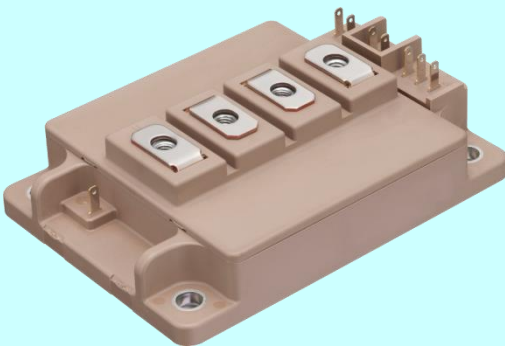
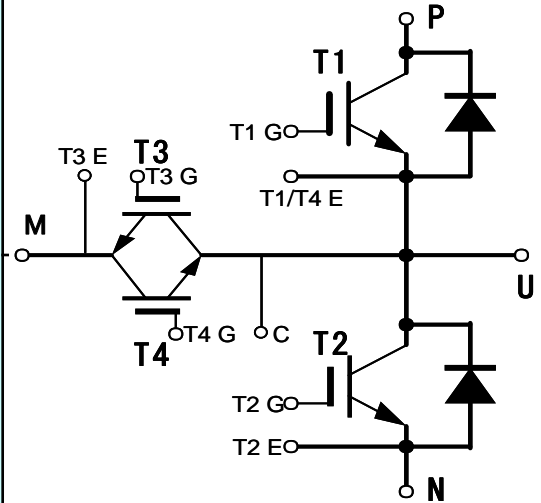
	IGBT part No.	Current	Voltage	Package	Equivalent circuit
M403(4in1)	4MBI400VG-060-50	400A	600V	M403:110 x 80 x 30mm 	
	4MBI300VG-120R-50	300A	1200V		
	4MBI400VG-120R-50	400A	1200V		

Switching Waveform of RB-IGBT

Equivalent circuit

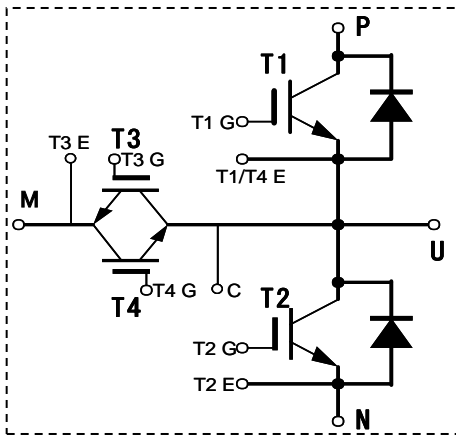

MT5F27333

T3 switching T1-FWD recovery mode

$T_j = RT$, $V_{cc2} = 400V$, $I_c = 300A$, $R_G = +8.2/-39\Omega$
 $V_{GE}(T3) = +/-15V$, $V_{GE}(T4) = +15V$,
 snubber = $1.84\mu F$, $L_s = 34nH$

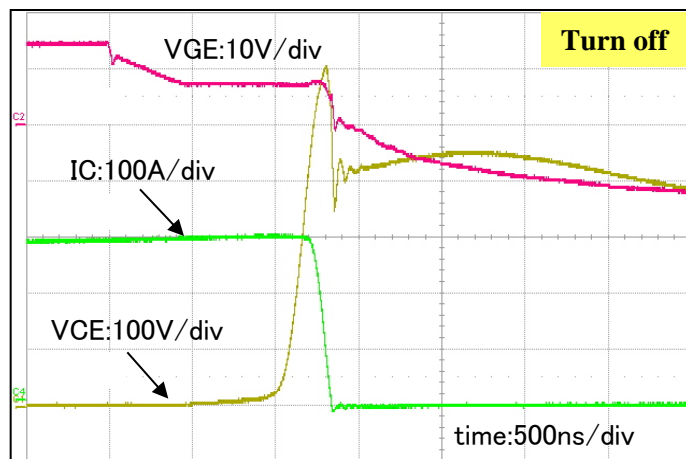
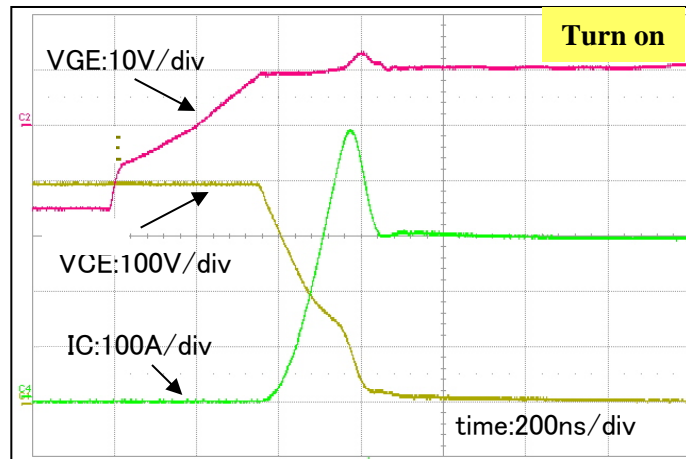

T1 switching T4 RB-IGBT recovery mode

$T_j = RT$, $V_{cc2} = 400V$, $I_c = 300A$, $R_G = +10\Omega$
 $V_{GE}(T1) = +/-15V$, $V_{GE}(T4) = +15V$,
 snubber = $1.84\mu F$, $L_s = 34nH$

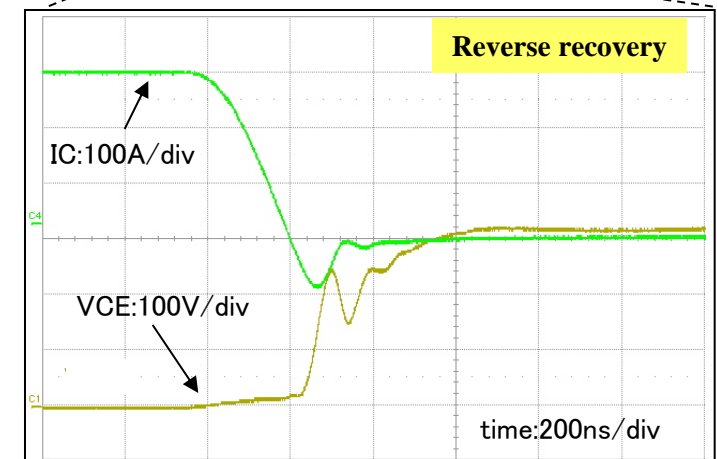
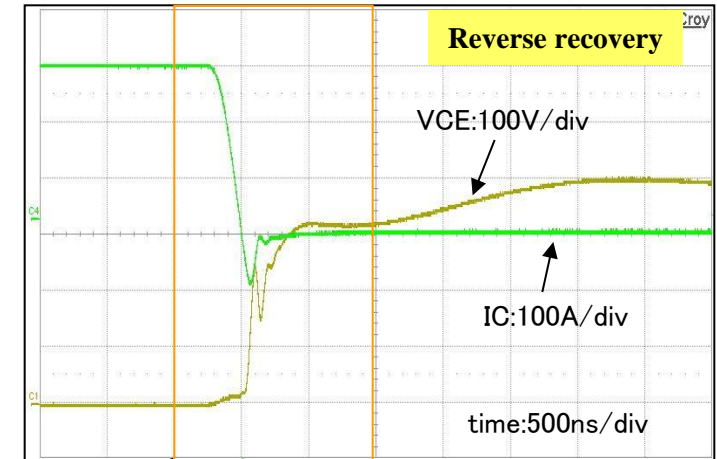

Fuji RB-IGBT can be realized of fast switching operation same as normal IGBT and FWD.

- Topology in solar inverter
- Fuji IGBT modules for solar inverter
- **Fuji solution in Gate Driver Unit (GDU)**
- Fuji 2 level topology solution
- Fuji 3 level topology solution - Stack

Fuji Solution in GDU for 2-level Topology



<http://igbt-driver.com/>



MT5F27333

Vces		1200V	
Package	Ic rating (A)	IGBT part No.	Plug-and-Play driver part No.
Dual XT	225	2MBI225VN-120-50	2SP0115T2Ax-2MBI225VN-120-50
	300	2MBI300VN-120-50	2SP0115T2Ax-2MBI300VN-120-50
	450	2MBI450VN-120-50	2SP0115T2Ax-2MBI450VN-120-50
	600	2MBI600VN-120-50	2SP0115T2Ax-2MBI600VN-120-50
PrimePACK™	600	2MBI600VXA-120E-50	2SP0320x2Ax-2MBI600VXA-120E-50
	900	2MBI900VXA-120E-50	2SP0320x2Ax-2MBI900VXA-120E-50
		2MBI900VXA-120P-50	2SP0320x2Ax-2MBI900VXA-120P-50
	1400	2MBI1400VXB-120E-50	2SP0320x2Ax-2MBI1400VXB-120E-50
2MBI1400VXB-120P-50		2SP0320x2Ax-2MBI1400VXB-120P-50	

Vces		1700V	
Package	Ic rating (A)	IGBT part No.	Plug-and-Play driver part No.
Dual XT	300	2MBI300VN-170-50	2SP0115T2Ax-17
	450	2MBI450VN-170-50	2SP0115T2Ax-2MBI450VN-170-50
	550	2MBI550VN-170-50	2SP0115T2Ax-2MBI550VN-170-50
PrimePACK™	650	2MBI650VXA-170E-50	2SP0320x2Ax-2MBI650VXA-170E-50
	1000	2MBI1000VXA-170E-50	2SP0320x2Ax-2MBI1000VXA-170E-50
	1400	2MBI1400VXB-170E-50	2SP0320x2Ax-2MBI1400VXB-170E-50
		2MBI1400VXB-170P-50	2SP0320x2Ax-2MBI1400VXB-170P-50

Note: PrimePACK™ are registered trademarks of Infineon Technology AG, Germany.

Fuji Solution in GDU for 2-level Topology

idc
イダ儿ヤ電子株式会社

<http://www.idc-com.co.jp/>

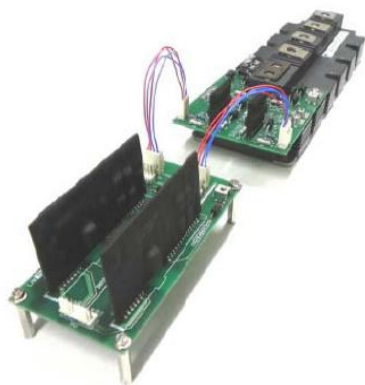

Ic rating (A)	600V	1200V	1700V
50	M57159L/VLA517	M5719L/VLA517	-
75	M57159L/VLA517	VLA541/VLA517	-
100	VLA541/VLA517	VLA541/VLA517	-
150	VLA541/VLA517	VLA541/VLA517	-
200	VLA541/VLA517	VLA542/VLA517	-
225	-	VLA542/VLA517	-
300	VLA542/VLA517	VLA542/VLA517	VLA546**
400	VLA542/VLA517	VLA500	-
450	-	VLA500	VLA500K
550	-	VLA500	VLA500K
600	VLA500	VLA500	VLA500K
650	-	-	VLA500K
800	-	VLA500	VLA500K
900	-	VLA500	-
1000	-	-	VLA539
1200	-	VLA539	VLA539
1400	-	VLA539	VLA539
1600	-	VLA539	VLA539
2400	-	Under investigation	Under investigation
3600	-	Under investigation	Under investigation

- Topology in solar inverter
- Fuji IGBT modules for solar inverter
- Fuji solution in Gate Driver Unit (GDU)
- **Fuji 2 level topology solution**
- Fuji 3 level topology solution - Stack

Parallel Connection of PrimePACK™

Side view

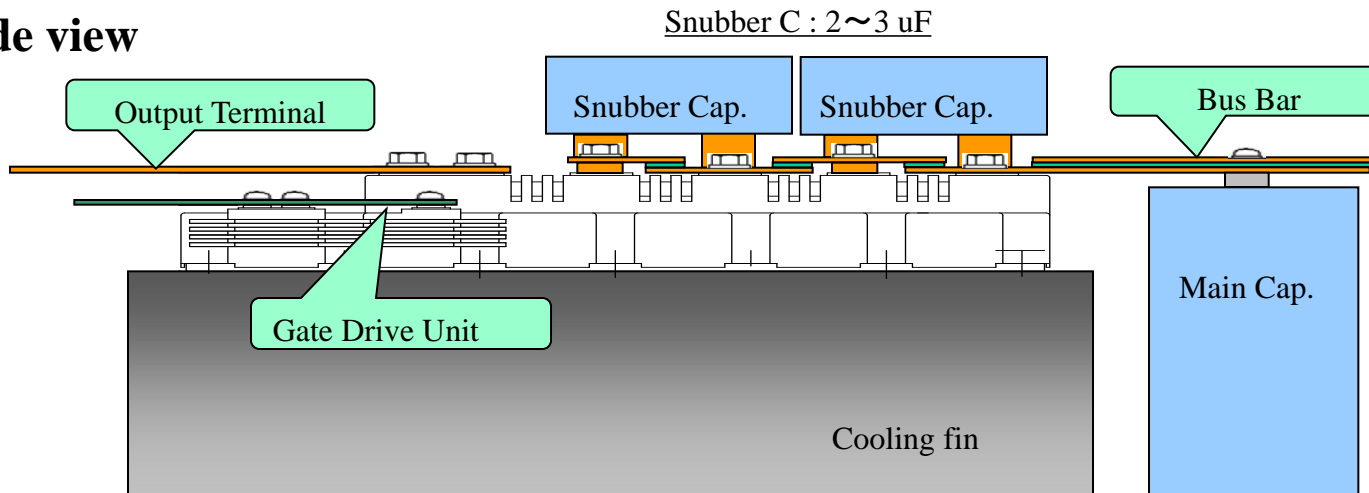

PrimePACK™ can easily construct inverter circuit . This figure shows the example.

Top view

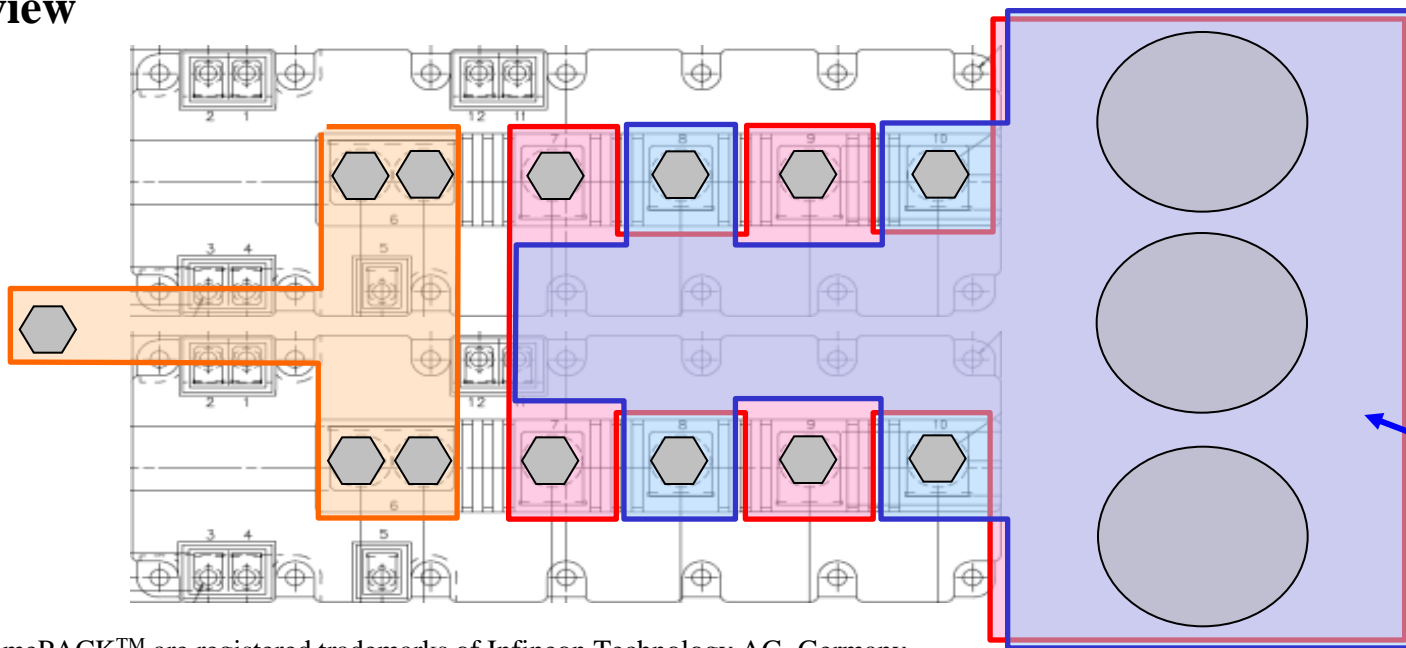

Laminate bus bar to realize low leakage inductance.

Note: PrimePACK™ are registered trademarks of Infineon Technology AG, Germany.

- Topology in solar inverter
- Fuji IGBT modules for solar inverter
- Fuji solution in Gate Driver Unit (GDU)
- Fuji 2 level topology solution
- **Fuji 3 level topology solution - Stack**

3-level Circuit Configuration (PrimePACK™)

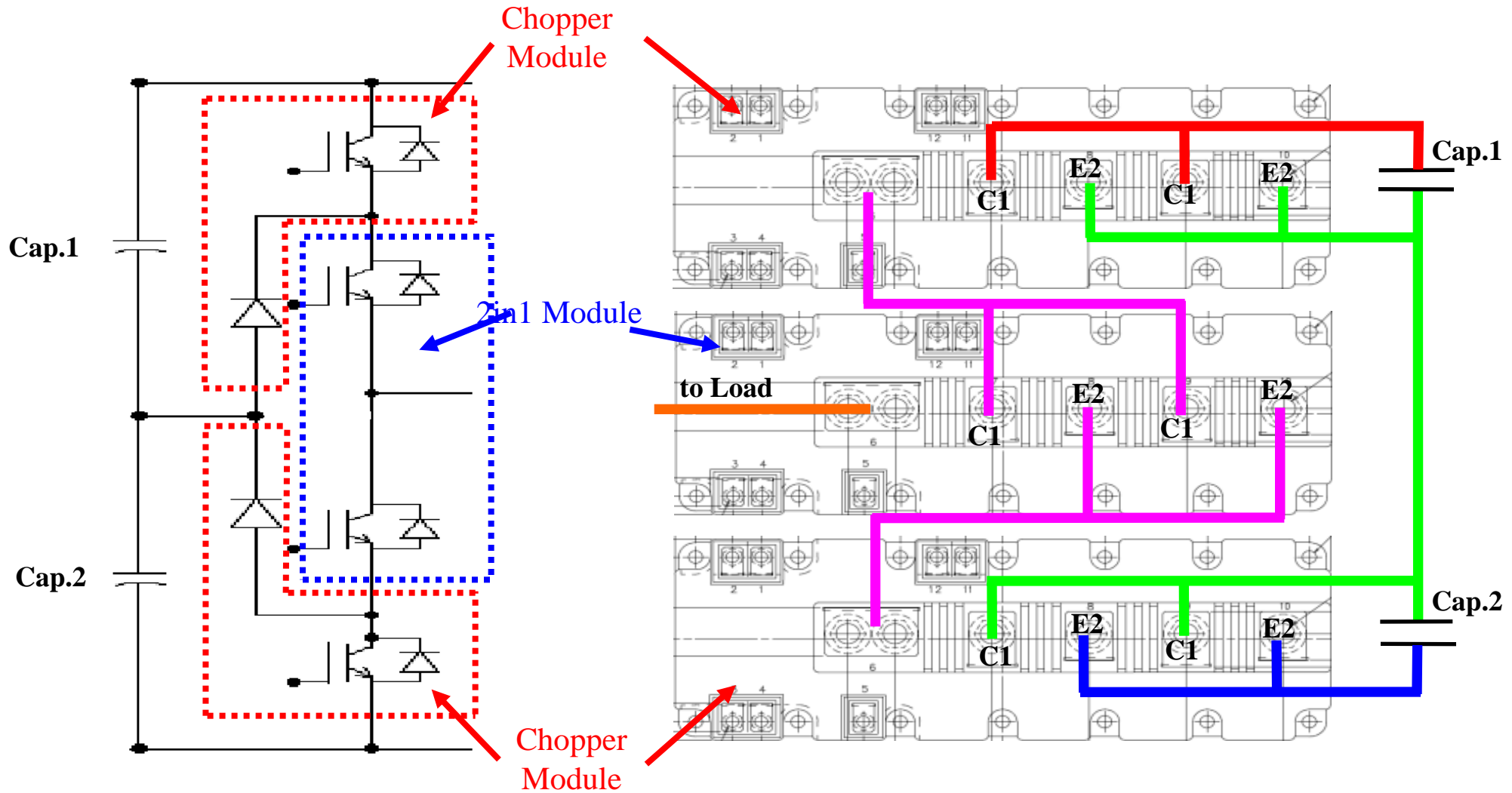

Easy connected “3 level inverter” by 2in1 module and chopper module

Parallel Connection of M403 (4in1)

A-NPC 3 level module * 2 parallel image

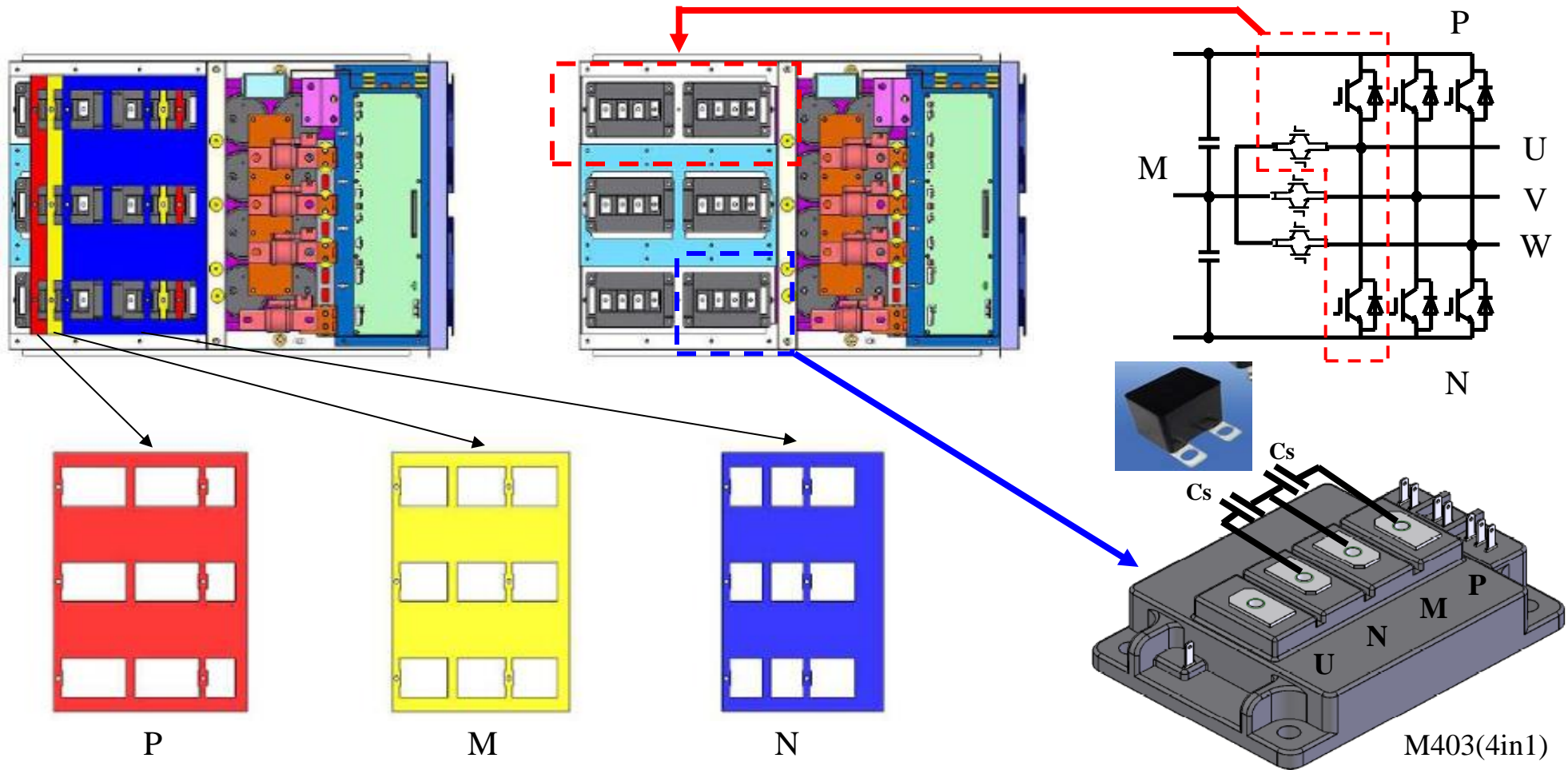

Parallel Connection of M403 (4in1)

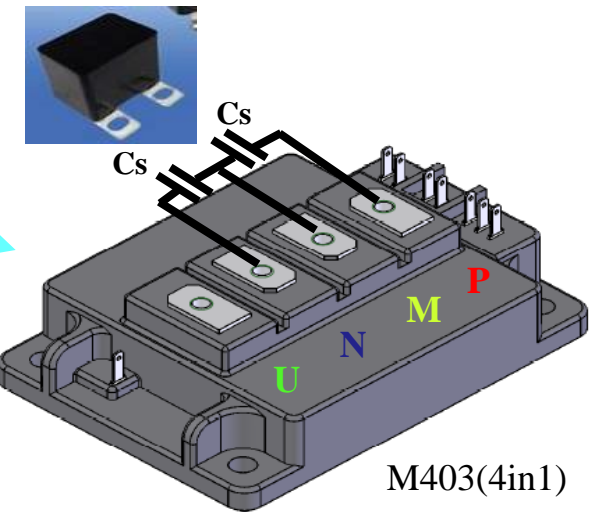
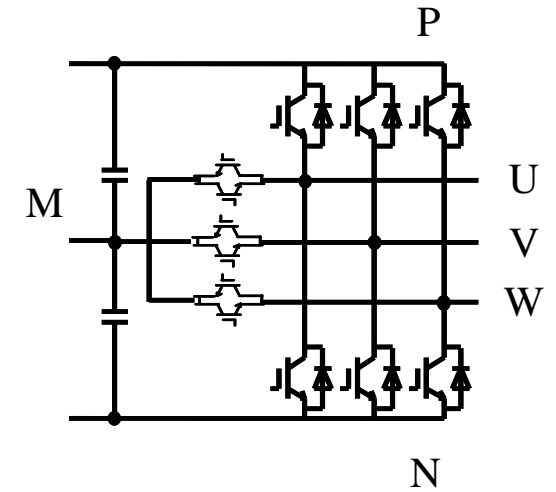
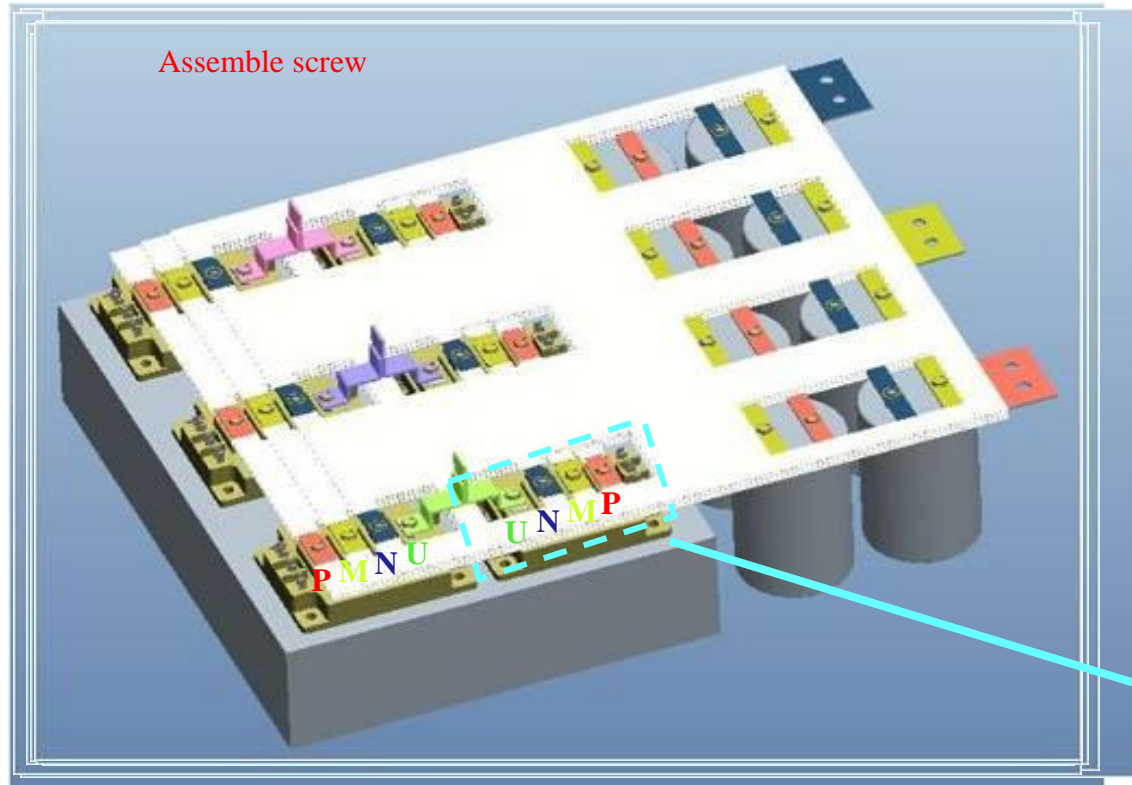

Current Imbalance of Paralleled Modules

V series 1200V IGBT/FWD and 600V RB-IGBT device for parallel standard module

A difference in the Von of two IGBT modules
Connected in parallel can cause a current imbalance.

$$\alpha = \left(\frac{I_1}{I_{c(ave)}} - 1 \right) \times 100\% \quad I_{c(ave)} = (I_1 + I_2) / 2$$

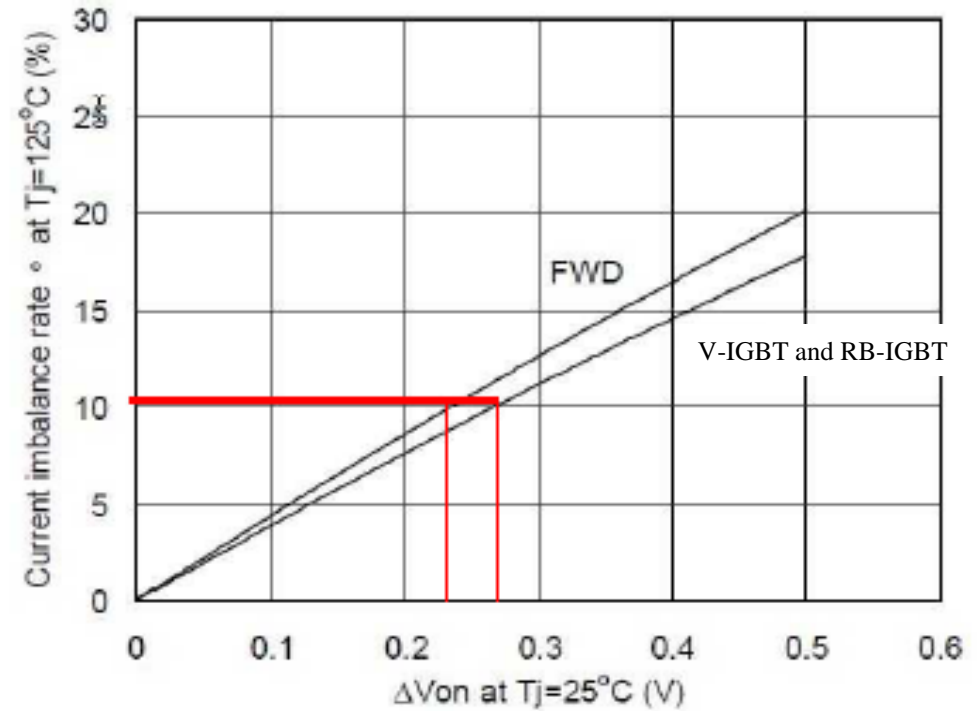
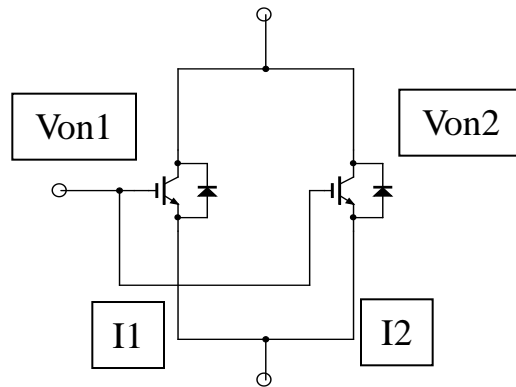

Deviation of $V_{CE(sat)}$ and current imbalance rate

- The condition of current imbalance rate within 10% for Von
- (1) Von of V-IGBT and RB-IGBT must be less than $\Delta 0.27V$.
 - (2) VF of FWD must be less than $\Delta 0.23V$.

If the modules are the same Lot. , it should be designed with $\alpha= 10\%$.
If the modules are not the same Lot., it should also be designed with $\alpha= 20\%$.

Connection method for auxiliary terminals

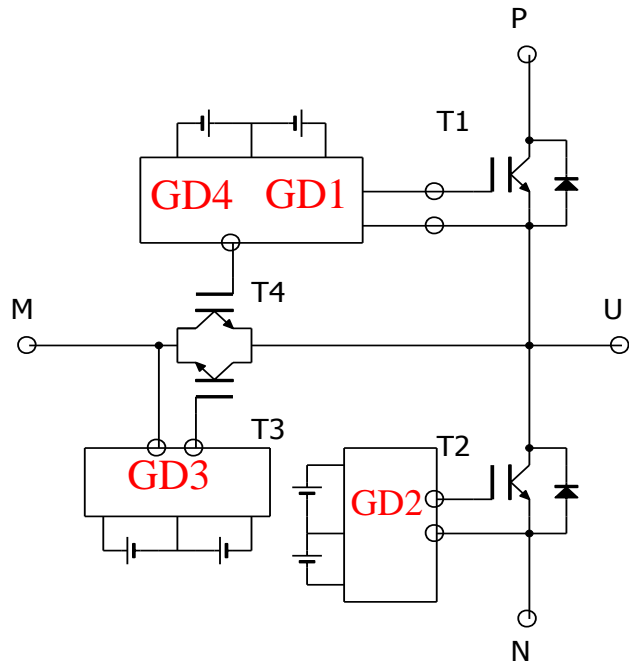

The emitter terminal of T1 and T4 is the same so that gate driver GD1 and GD4 can be used with the same gate driver power supply.

Three gate driver power supplies are enough for M403.

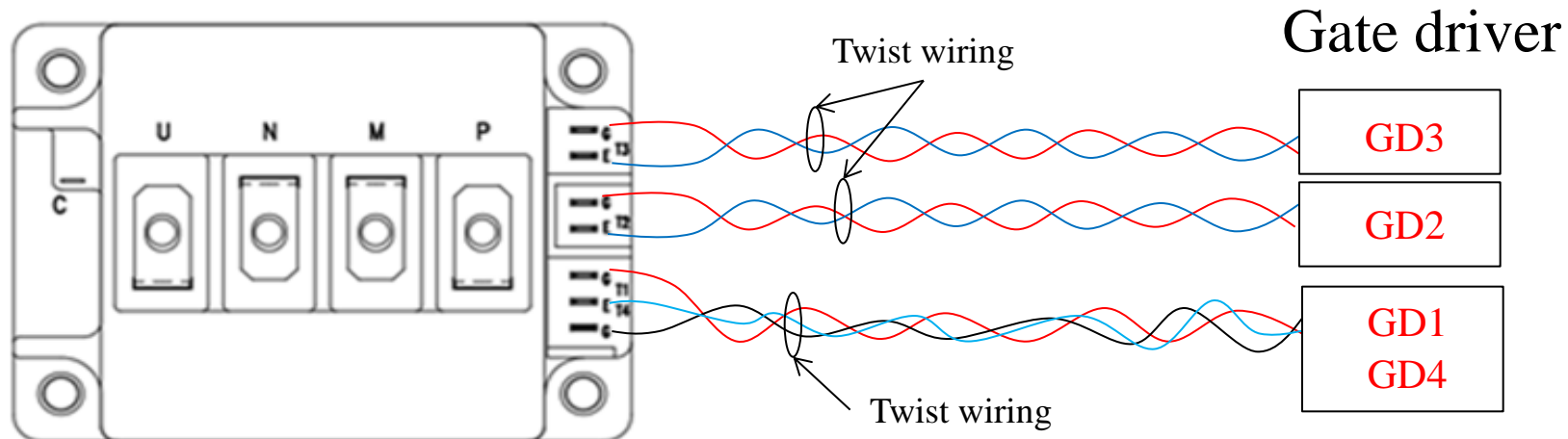

Gate driver

$$C_s = \frac{L * I_o^2}{(V_{CEP} - E_d)^2}$$

L: Main circuit wiring parasitic inductance

I_o: Collector current at IGBT turn-off

V_{CEP}: Snubber capacitor peak voltage

E_d: DC supply voltage

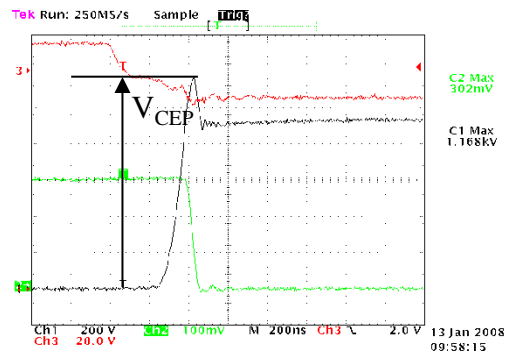

Module rating		DC line inductance	snubber capacitance
V _{ces}	I _c		
1200V/1700V	100A	0.2 μ H	0.47μ F
	300A	0.1μ H	3.3μ F
	450A	0.08 μ H	4.7μ F
	1000A	0.07μ H	6.8μ F
	1400A	0.06μ H	12μ F

Snubber Capacitor for M403

M403 (4in1)



Capacitor for Snubber circuit

➤ 4-in-1 package for T-type 3-level circuits

Specifications

	600YC	
Category Temperature Range	-40 ~ +105°C	
Rated Voltage	600Vdc	
Capacitance	1.0μF * 2	
Capacitance Tolerance	±10% (K)	
Permissible Current	8.0Arms (at 10kHz)	
ESL	≤ 20 nH (at 10MHz)	
Voltage Proof	Between the terminals	900Vdc
	Between the terminal and case	2000Vdc
Insulation Resistance	Between the terminals	≥ 1500M Ω
Case	PPS	
Filling Resin	Epoxy Resin	

*Different capacitance and rated voltage item is available.

Circuit

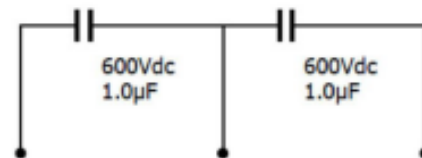

Outline

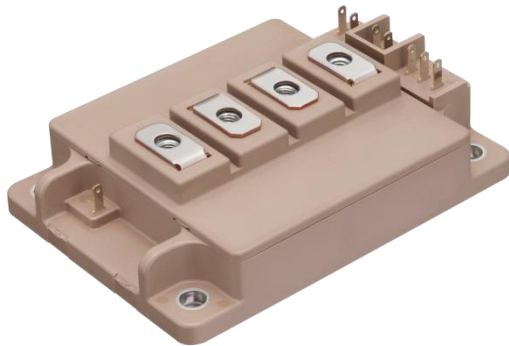
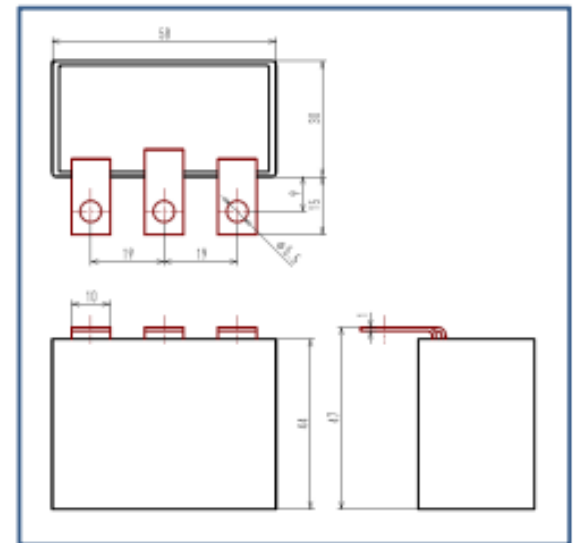

For more information:

Please visit : <http://www.rubycon.co.jp/en/profile/oversea.html>