

---

# Chapter 4

## Examples of Application Circuits

---

Contents	Page
1. Examples of Application Circuits.....	4-2
2. Precautions .....	4-7
3. Photocoupler and Peripheral Circuits .....	4-10
4. Connectors .....	4-11

**1** Examples of Application Circuits

Fig. 4-1 shows an example of an application circuit for P610, P611, and P612 (types with built-in brake).

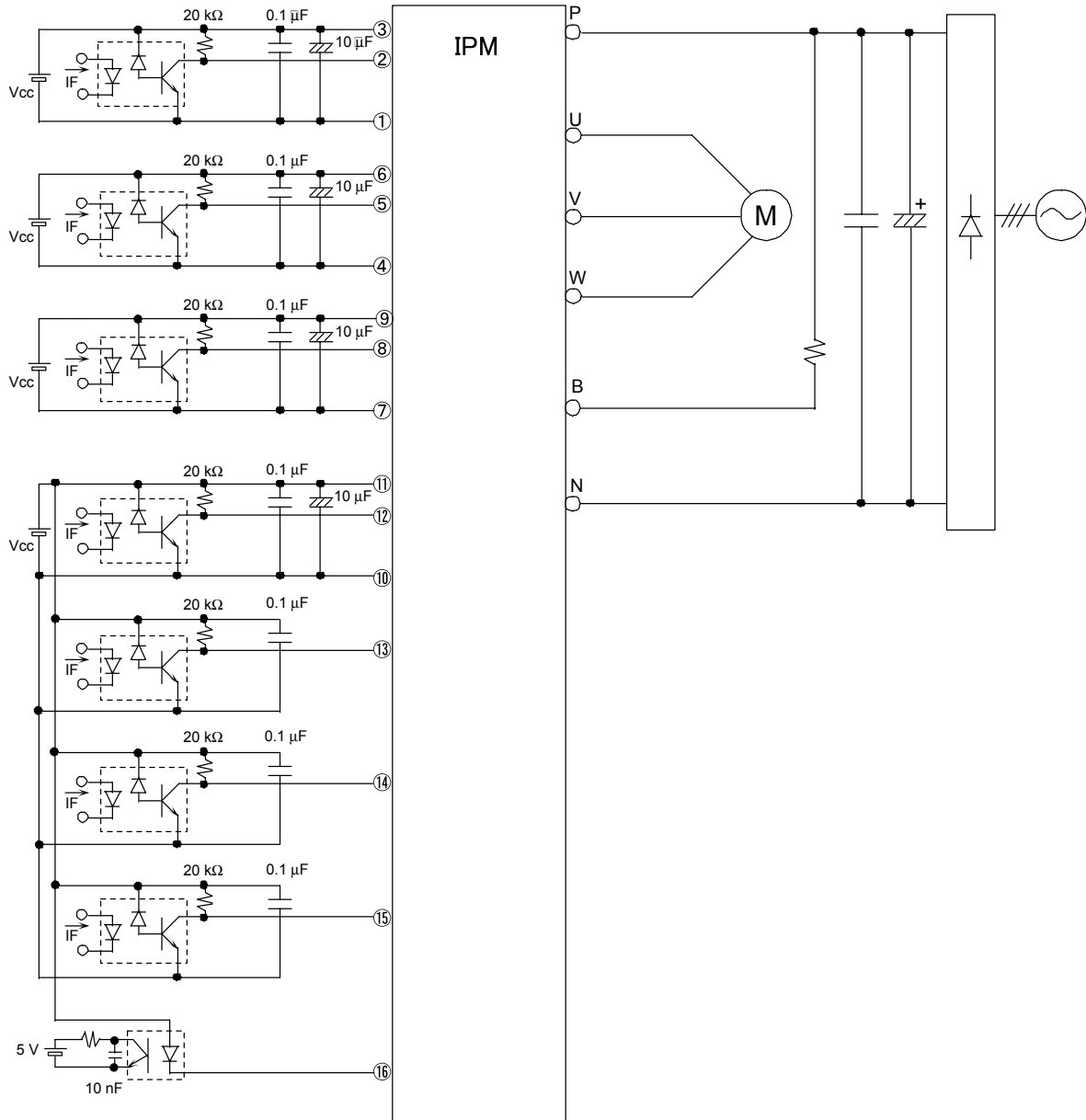

Fig. 4-1 Example of Application Circuit for P610, P611, and P612 (Types with Built-in Brake)

Fig. 4-2 shows an example of an application circuit for P610, P611, and P612 (types without brake).

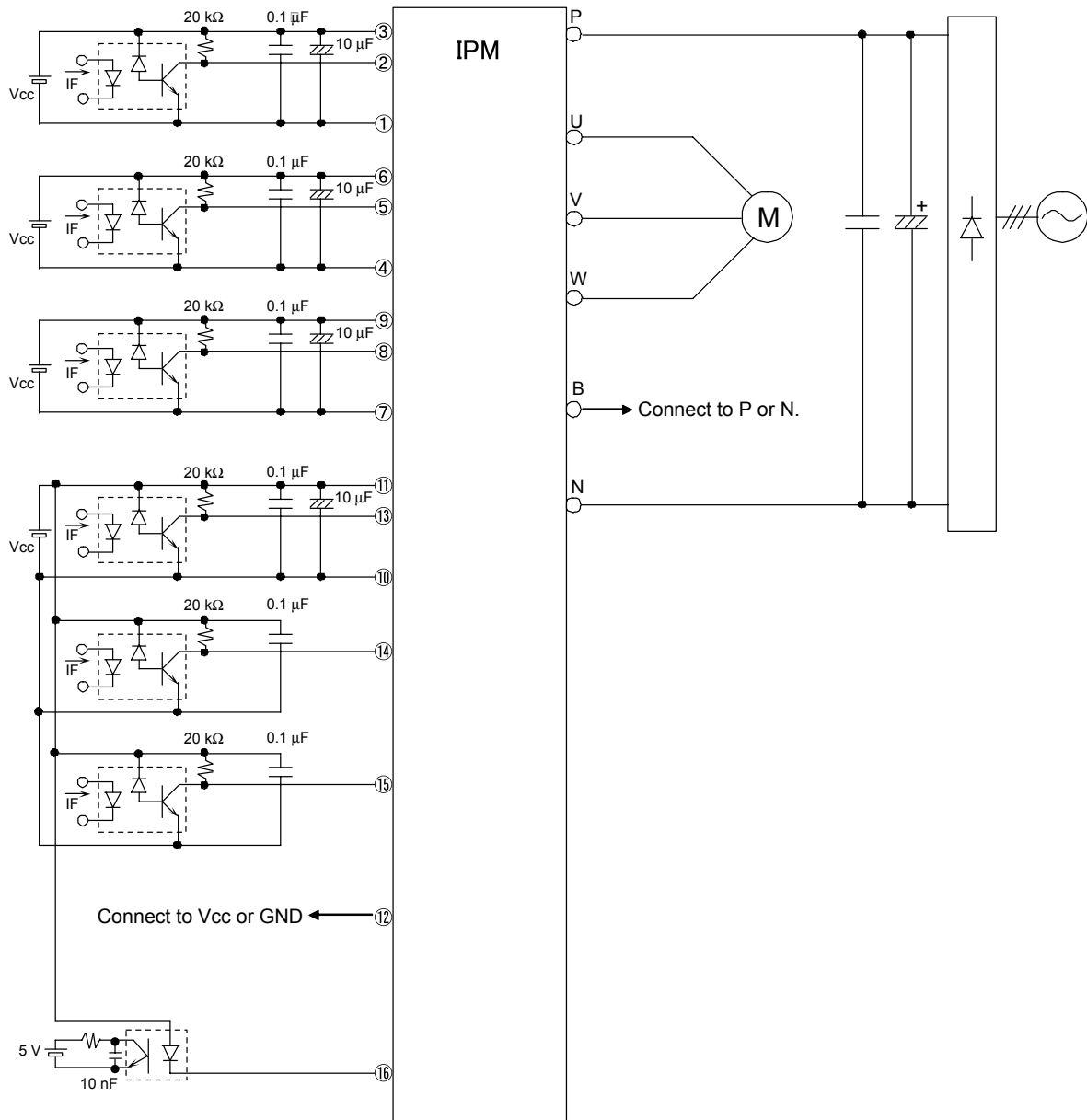

Fig. 4-2 Example of Application Circuit for P610, P611, and P612 (Types Without Brake)

Fig. 4-3 shows an example of an application circuit for P621 and P622 (types with built-in brake).

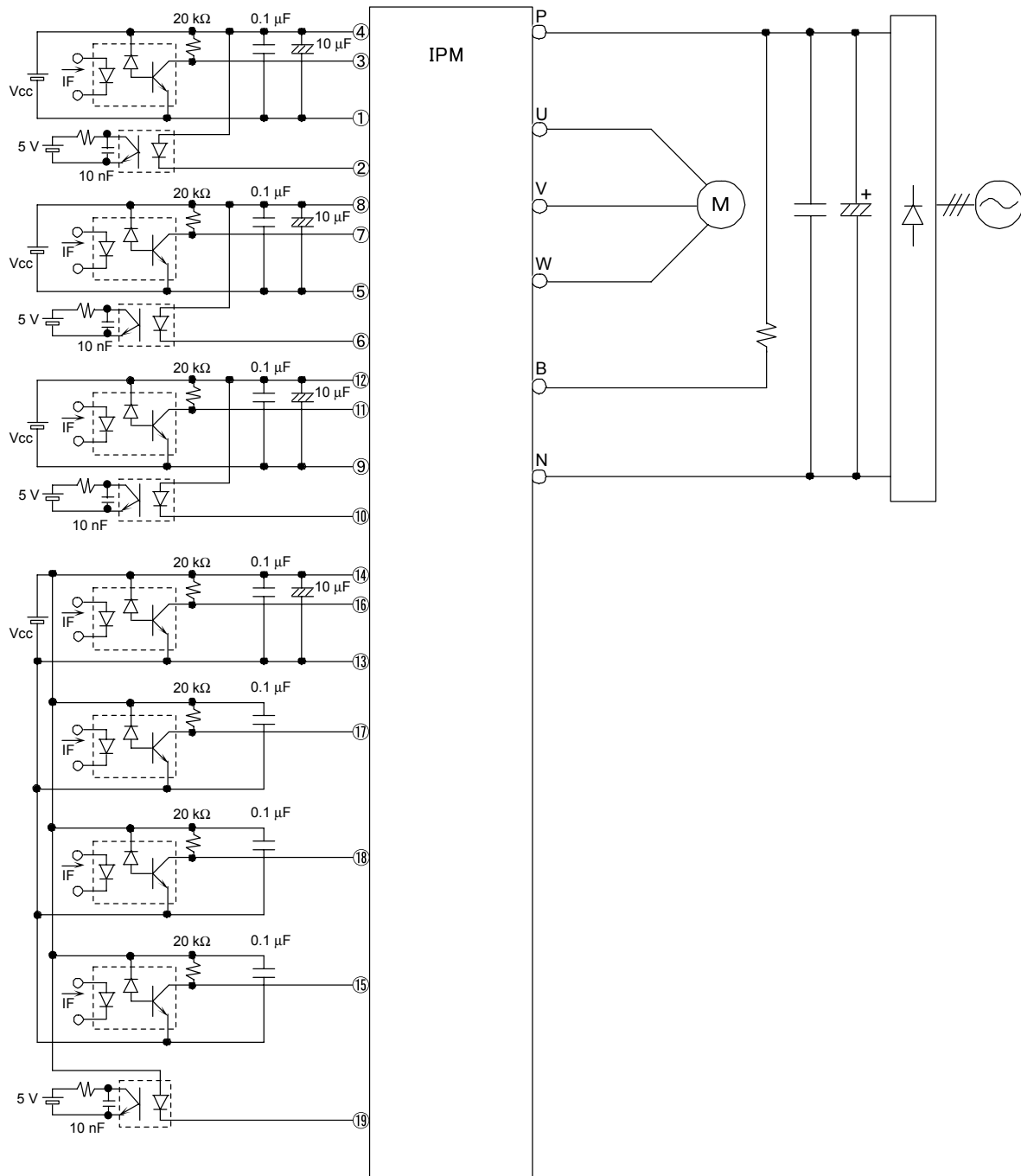

Fig. 4-3 Example of Application Circuit for P621, P622 (with Upper Arm Alarm)  
(Types with Built-in Brake)

Fig. 4-4 shows an example of an application circuit for P621 and P622 (types without brake).

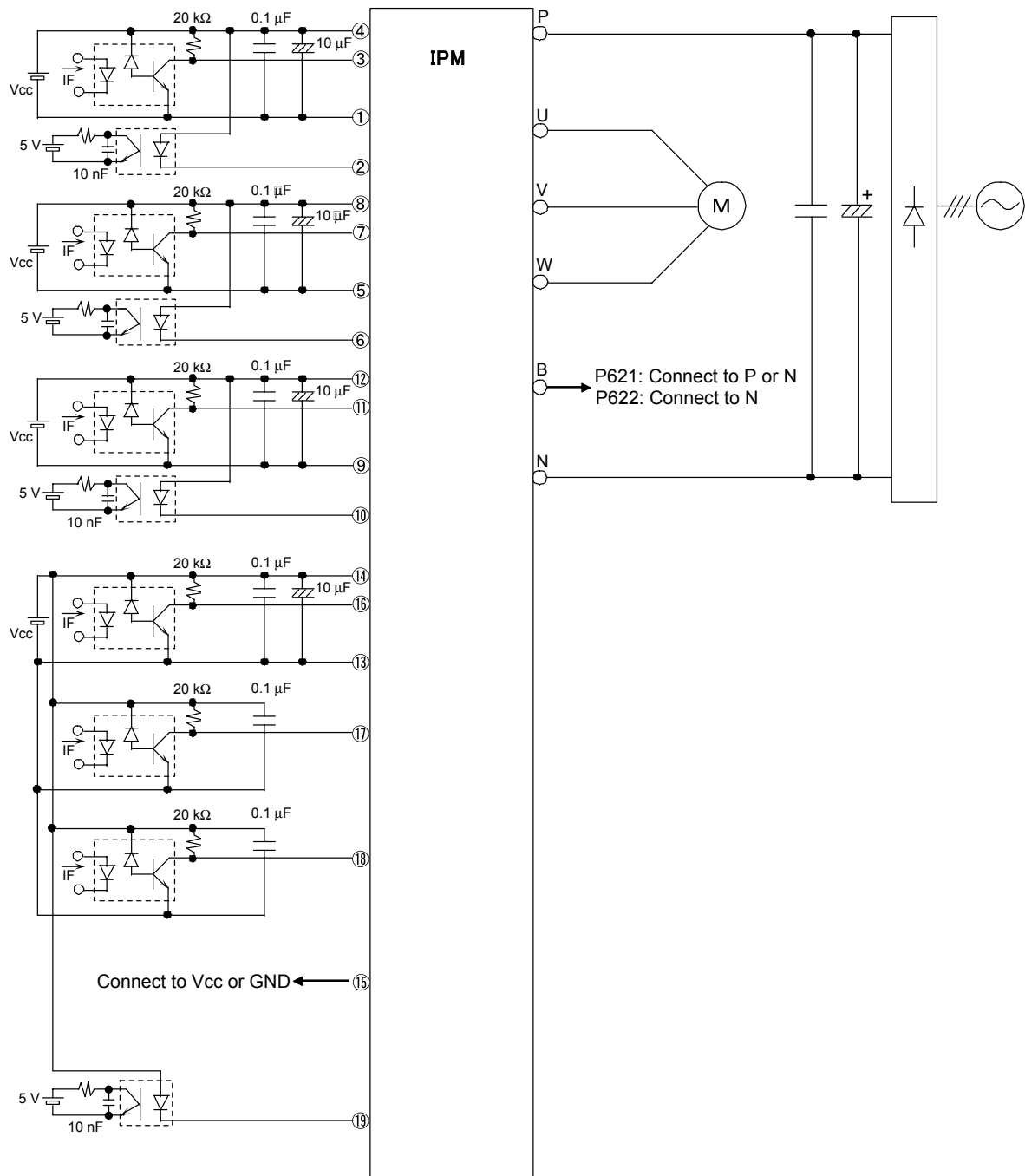

Fig. 4-4 Example of Application Circuit for P621, P622 (with Upper Arm Alarm) (Types Without Brake)

Fig. 4-5 shows an example of an application circuit for P617.

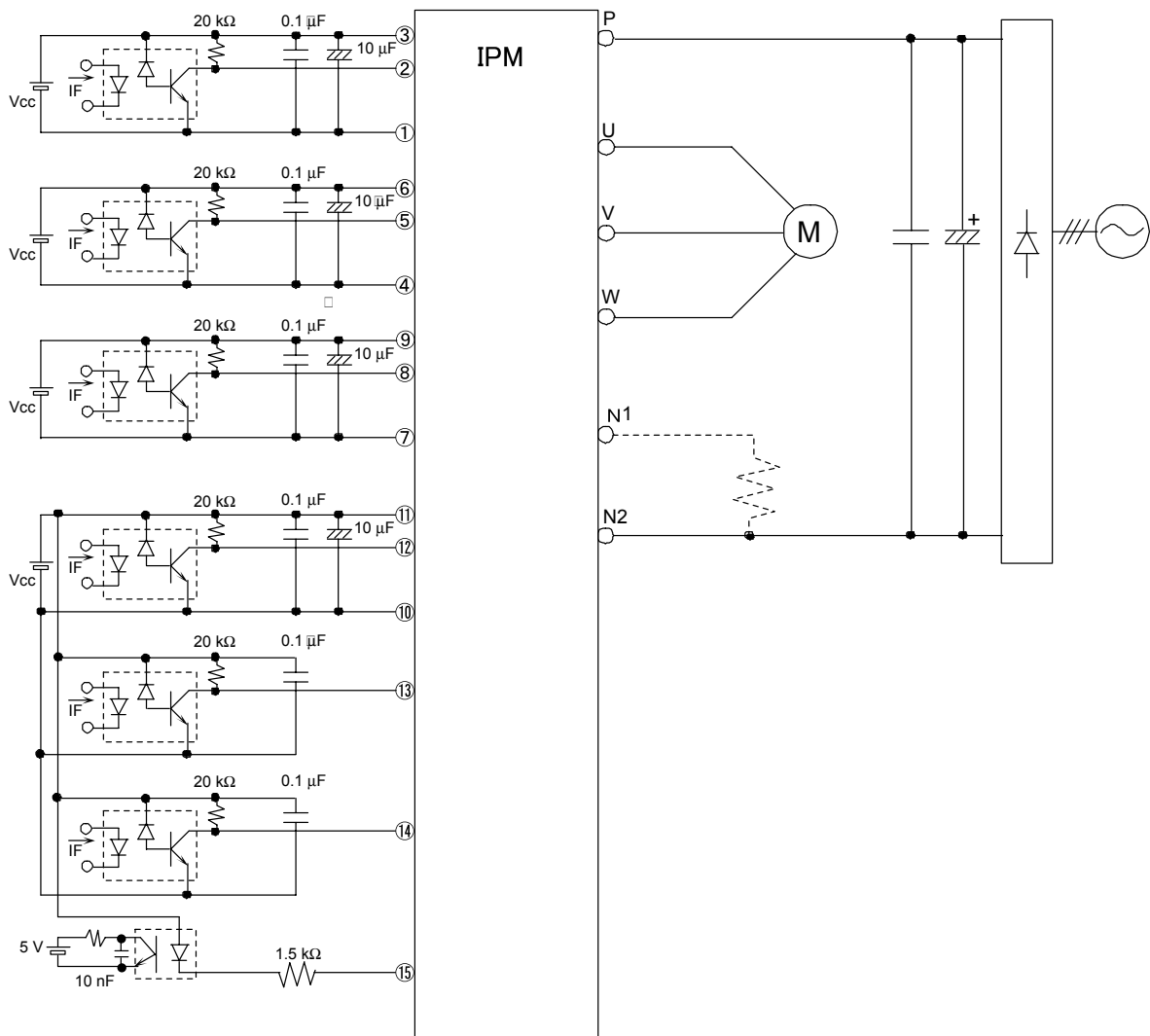

Fig. 4-5 Example of Application Circuit for Small-capacity IPM P617

Fig. 4-6 shows an example of an application circuit for P619.

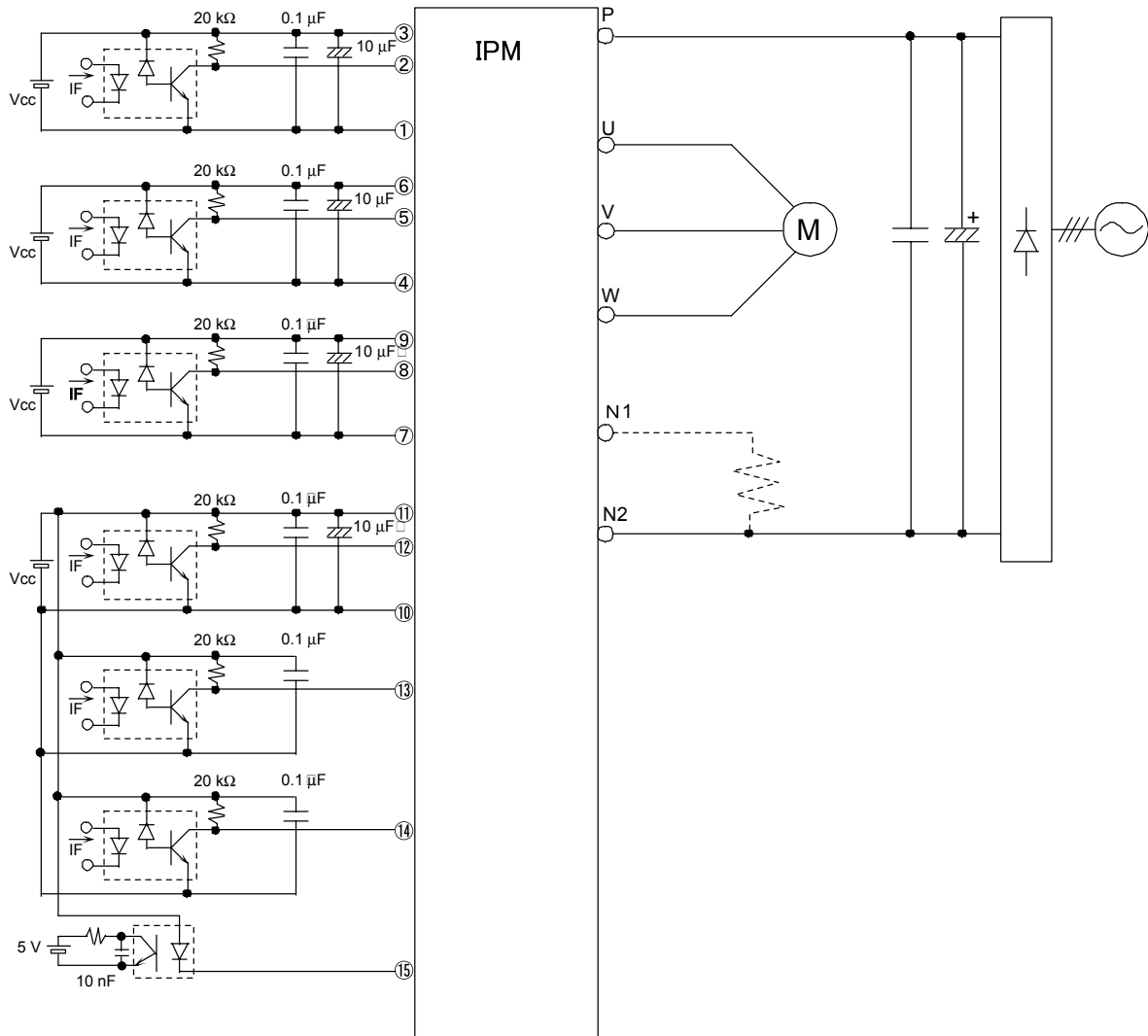

Fig. 4-6 Example of Application Circuit for Small-capacity IPM P619

## 2 Precautions

### 2.1 Control power source

As shown in the application circuit examples, a total of four isolation power sources are required for the control power sources, 3 on the upper arm side and 1 on the lower arm side.

If you are using commercial power source units, do not connect the GND terminal on the side of the power source output.

When the GND on the output side is connected to + or -, faulty operation occurs because each power source is connected to the ground on the side of power source input. Stray capacity between each power source and ground should be reduced to a minimum.

### 2.2 Structural isolation among four power sources (input connectors and PC boards)

Isolation is needed between each of the four power sources and the main power source.

Since a large amount of  $dv/dt$  is applied to this isolation during IGBT switching, keep sufficient clearance between the components and the isolation. (2 mm or more is recommended.)

### 2.3 GND connection

The control power source GND on the lower arm side and the main power source GND are connected inside the IPM. Never connect them outside the IPM. If you connect them outside the IPM, loop currents generated inside and outside the IPM flow to the lower arm due to  $di/dt$  and cause malfunctioning of the photocoupler and the IPM. The input circuit of the IPM may also be damaged.

### 2.4 Control power source capacitor

The 10  $\mu\text{F}$  and 0.1  $\mu\text{F}$  capacitors connected to each control power source as shown in the application circuit examples are not intended for smoothing the control power sources, but for compensating the wiring impedance up to the IPM. Capacitors for smoothing are needed separately.

Since transient variations may be caused in the wiring impedance from the capacitor to the control circuit, connect the capacitor as close to the IPM control terminal and photocoupler pin as possible.

Select capacitors with lower impedance and better frequency characteristics for the electrolytic capacitors. In addition, connect capacitors with better frequency characteristics, such as film capacitors, in parallel.

### 2.5 Alarm circuits

- The potential on the secondary side of the alarm photocoupler may vary due to  $dv/dt$ . It is recommended to stabilize the potential by connecting a capacitor of approximately 10 nF.
- As P617 does not have a built-in alarm resistor, a resistor of 1.5 k $\Omega$  must be connected on the outside of the IPM.

### 2.6 Pull-up of the signal input terminal

Pull up the control signal input terminal to  $V_{cc}$  with a resistor of 20 k $\Omega$ . Even if you do not use the brake in the built-in brake IPM, still pull up the DB input terminal. If you do not pull up the terminal, a malfunction may be caused by  $dv/dt$ .

### 2.7 Snubber

Connect the snubber to the PN terminals directly. For the P612 package set up the snubber for each PN terminal on both sides.

### 2.8 B terminal

In the case of the 6 in 1 package (without brake) type, connecting the B terminal to the N or P terminal as described below is recommended.

P610, P611, P612, P621 .....N or P terminal

P622(Econo-IPM) .....N terminal (connection to the P terminal causes an internal short-circuit)



**2.9 Upper arm alarm**

When the upper arm alarm of an IPM with upper arm alarm output is not used, connect the alarm terminal to Vcc to stabilize the potential.

**2.10 Overcurrent protection for small-capacity IPMs**

The limit level for overcurrent protection can be adjusted to a high level by adding a resistor between the N1 and N2 terminals of small-capacity IPMs (P617, 619). The resistor added at that time must be mounted close to the N1 and N2 terminals. A long distance from the N1 and N2 terminals can cause faulty operation of the IPM.

**2.11 IPM input circuit**

The constant-current circuit shown in Fig. 4-7 is provided in the input section of our IPMs, and outflow from the IPM takes place at the timing shown in the figure. For this reason, the IF on the primary side of the photocoupler must be determined so that a current of  $I_R + 1\text{ mA}$  flows through the pull-up resistor on the secondary side of the photocoupler. If the IF is not sufficient, faulty operation on the secondary side is possible.

Also, the pull-up resistor must be selected so that a current of  $I_R + 1\text{ mA}$  flows on the secondary side of the photocoupler when the photocoupler is ON and that the current flowing into the IPM at the time of OFF does not exceed the  $I_{in\text{ MAX}}$  listed in the specifications.

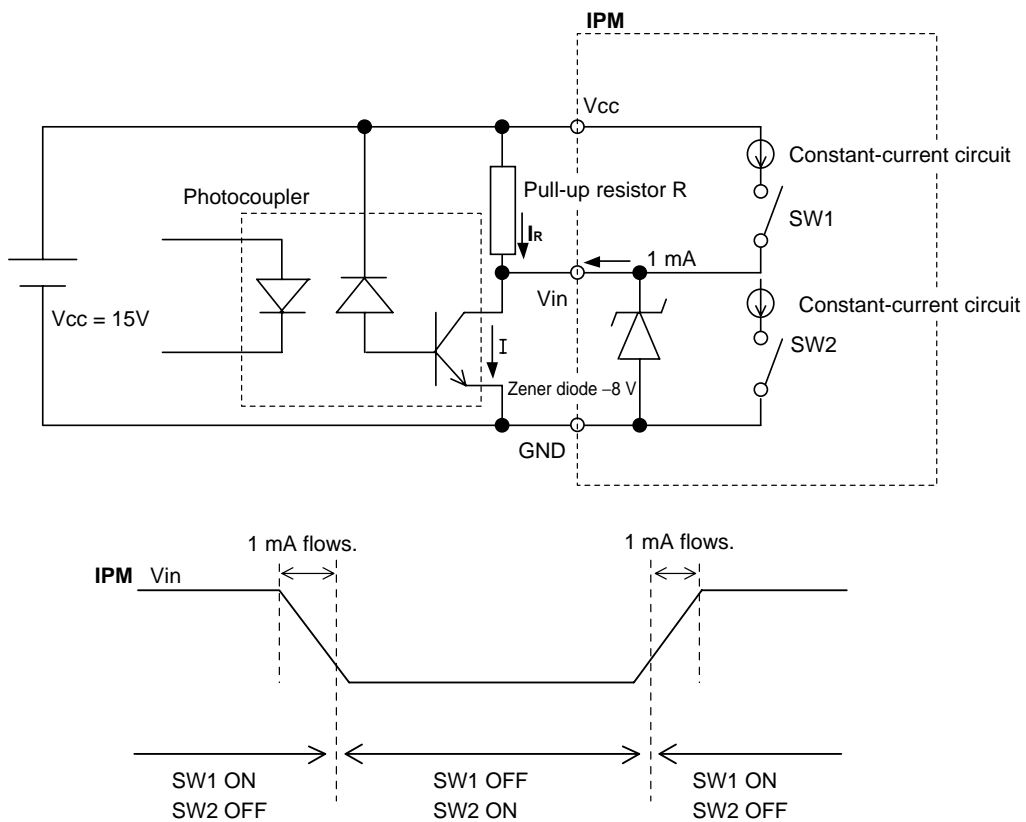

Fig. 4-7 IPM Input Circuit and Rated Current Operation Timing

### 3 Photocoupler and Peripheral Circuits

#### 3.1 Photocoupler for control input

- Photocoupler rating

Use a photocoupler satisfying the following characteristics.

- $CMH = CML > 15 \text{ kV}/\mu\text{s}$  or  $10 \text{ kV}/\mu\text{s}$
- $tpHL = tpLH < 0.8 \mu\text{s}$
- $tpLH - tpHL = -0.4$  to  $0.9 \mu\text{s}$
- $CTR > 15\%$

Example: Product of Agilent: HCPL-4504

Product of Toshiba: TLP759 (IGM)

Note: Safety standards such as UL and VDE should also be applied.

- Wiring between photocoupler and IPM

Make the wiring between the photocoupler and the IPM as short as possible to reduce the wiring impedance between the photocoupler and the IPM control terminal. Separate each wire between the primary and secondary circuits so that floating capacitance does not become large, since a strong  $dv/dt$  is applied between the primary and secondary circuits.

- Light emitting diode driving circuit

The  $dv/dt$  withstand capability of the photocoupler is also affected by the input light emitting diode driving circuit. A driving circuit example is shown in Fig. 4-8.

Good example: Totempole output IC

Current limiting resistor on the cathode side of the photo diode

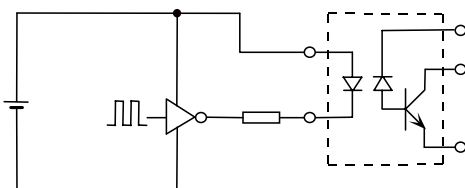

Bad example: Open collector

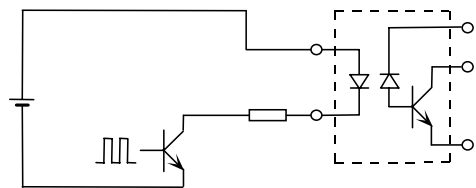

Good example: Photo diode A-K is shorted by transistors C-E (example which is particularly fit for photocoupler OFF)

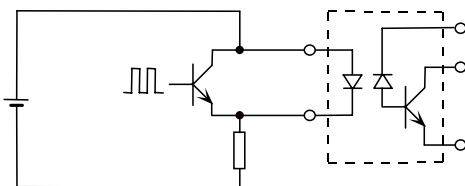

Bad example: Current limiting resistor on the anode side of the photo diode

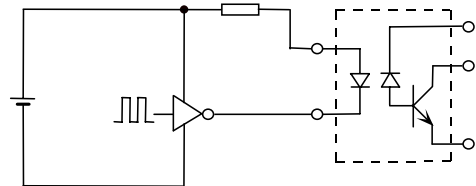

Fig. 4-8 Photocoupler Input Circuits

### 3.2 Photocoupler for alarm output

- Photocoupler rating

General-purpose photocouplers can be used, but photocouplers satisfying the following characteristics are recommended.

- $100\% < \text{CTR} < 300\%$
- Single-element type

Example: TLP521-1-GR rank

Note: Safety standards such as UL and VDE should also be applied.

- Input current limiting resistor

A current limiting resistor for the light emitting diode in the photocoupler input is included in the IPM.

$R_{\text{ALM}} = 1.5 \text{ k}\Omega$  and if connected directly to  $V_{\text{CC}}$ , about 10 mA of  $I_{\text{F}}$  flows with  $V_{\text{CC}} = 15 \text{ V}$ .

Therefore, there is no need to connect any current limiting resistor.

However, if a large amount of current, i.e.,  $I_{\text{out}} > 10 \text{ mA}$ , is needed on the photocoupler output, increase the CTR value of the photocoupler to the required value.

- Wiring between the photocoupler and the IPM

Since a large amount of  $dv/dt$  is also applied on the photocoupler for the alarm, the same precautions as described in 3.1 should be taken.

## 4 Connectors

Connectors suitable for the shape of the R-IPM control terminals are commercially available.

16-pin connector for P610, 611, 612: MDF7-25S-2.54DSA made by Hirose Electric

For P621: DF10-31S-2DSA made by Hirose Electric

Please confirm the reliability and the specifications of the above connectors with the manufacturer.

## WARNING

1. This Catalog contains the product specifications, characteristics, data, materials, and structures as of February 2004.  
The contents are subject to change without notice for specification changes or other reasons. When using a product listed in this Catalog, be sure to obtain the latest specifications.
2. All applications described in this Catalog exemplify the use of Fuji's products for your reference only. No right or license, either express or implied, under any patent, copyright, trade secret or other intellectual property right owned by Fuji Electric Device Technology Co., Ltd. is (or shall be deemed) granted. Fuji Electric Device Technology Co., Ltd. makes no representation or warranty, whether express or implied, relating to the infringement or alleged infringement of other's intellectual property rights which may arise from the use of the applications described herein.
3. Although Fuji Electric Device Technology Co., Ltd. is enhancing product quality and reliability, a small percentage of semiconductor products may become faulty. When using Fuji Electric semiconductor products in your equipment, you are requested to take adequate safety measures to prevent the equipment from causing a physical injury, fire, or other problem if any of the products become faulty. It is recommended to make your design fail-safe, flame retardant, and free of malfunction.
4. The products introduced in this Catalog are intended for use in the following electronic and electrical equipment which has normal reliability requirements.
  - Computers
  - OA equipment
  - Communications equipment (terminal devices)
  - Measurement equipment
  - Machine tools
  - Audiovisual equipment
  - Electrical home appliances
  - Personal equipment
  - Industrial robots etc.
5. If you need to use a product in this Catalog for equipment requiring higher reliability than normal, such as for the equipment listed below, it is imperative to contact Fuji Electric Device Technology Co., Ltd. to obtain prior approval. When using these products for such equipment, take adequate measures such as a backup system to prevent the equipment from malfunctioning even if a Fuji's product incorporated in the equipment becomes faulty.
  - Transportation equipment (mounted on cars and ships)
  - Trunk communications equipment
  - Traffic-signal control equipment
  - Gas leakage detectors with an auto-shut-off feature
  - Emergency equipment for responding to disasters and anti-burglary devices
  - Safety devices
6. Do not use products in this Catalog for the equipment requiring strict reliability such as (without limitation)
  - Space equipment
  - Aeronautic equipment
  - Nuclear control equipment
  - Submarine repeater equipment
  - Medical equipment
7. Copyright © 1996-2004 by Fuji Electric Device Technology Co., Ltd. All rights reserved.  
No part of this Catalog may be reproduced in any form or by any means without the express permission of Fuji Electric Device Technology Co., Ltd.
8. If you have any question about any portion in this Catalog, ask Fuji Electric Device Technology Co., Ltd. or its sales agents before using the product.  
Neither Fuji Electric Device Technology Co., Ltd. nor its agents shall be liable for any injury caused by any use of the products not in accordance with instructions set forth herein.