

Small IPM (Intelligent Power Module)

P633A Series

6MBP**XS*060-50

Application Manual

Cautions

This Instruction contains the product specifications, characteristics, data, materials, and structures as of June 2022. The contents are subject to change without notice for specification changes or other reason. When using a product listed in this Instruction be sure to obtain the latest specifications.

The application examples in this note show the typical examples of using Fuji products and this note shall neither assure to enforce the industrial property including some other rights nor grant the license.

Although Fuji Electric Co., Ltd. continually strives to enhance product quality and reliability, a small percentage of semiconductor products may become faulty. When using Fuji Electric semiconductor products in your equipment, be sure to take adequate safety measures such as redundant, flame-retardant and fail-safe design in order to prevent a semiconductor product failure from leading to a physical injury, property damage or other problems.

The products described in this application manual are manufactured with the intention of being used in the following industrial electronic and electrical devices that require normal reliability.

- Compressor motor inverter
- Fan motor inverter for room air conditioner
- Compressor motor inverter for heat pump applications, etc.

If you need to use a semiconductor product in this application note for equipment requiring higher reliability than normal, such as listed below, be sure to contact Fuji Electric Co., Ltd. to obtain prior approval. When using these products, take adequate safety measures such as a backup system to prevent the equipment from malfunctioning when a Fuji Electric's product incorporated in the equipment becomes faulty.

- Transportation equipment (mounted on vehicles and ships)
- Trunk communications equipment
- Traffic-signal control equipment
- Gas leakage detectors with an auto-shutoff function
- Disaster prevention / security equipment
- Safety devices, etc.

Do not use a product in this application note for equipment requiring extremely high reliability such as:

- Space equipment • Airborne equipment • Atomic control equipment
- Submarine repeater equipment • Medical equipment

All rights reserved. No part of this application note may be reproduced without permission in writing from Fuji Electric Co., Ltd.

If you have any question about any portion of this application note, ask Fuji Electric Co., Ltd. or its sales agencies. Neither Fuji Electric Co., Ltd. nor its agencies shall be liable for any injury or damage caused by any use of the products not in accordance with instructions set forth herein.

Chapter 1 Product Outline

1. Introduction	1-2
2. Product line-up	1-5
3. Definition of Type Name and Marking Spec	1-6
4. Package outline dimensions	1-8
5. Absolute Maximum Ratings	1-10

The objective of this manual is to introduce Fuji IGBT Intelligent-Power-Module “Small-IPM”.

First, the product outline of this module is described.

Next, the terminal symbols and terminology used in this manual and the specification sheet are explained. Then, the design guidelines for signal input terminals and power terminals are shown. Finally, the recommended wiring and layout, along with the mounting guidelines are given.

1. Introduction

<Product concept>

- 7th gen. IGBT technology offers high-efficiency and energy-saving operation.
- Guarantee $T_{vjop}=150^{\circ}\text{C}$ allows expansion of output current.
- Higher accuracy of short circuit detection contribute to expansion of over load operating area.
- Compatible pin assignments, foot print size and mounting dimensions with 1st gen. Small IPM series.
- Product range: 15A – 35A / 600V.
- The total dissipation loss has been improved by improvement of the trade-off between the Collector-Emitter saturation voltage $V_{CE(sat)}$ and switching loss.

<Built-in drive circuit>

- Drives the IGBT under optimal conditions.
- The control IC of upper side arms (HVIC) have a built-in high voltage level shift circuit.
- This product can be driven directly by a microprocessor on both the upper side and lower side arms. The voltage level of input signals are 3.3V or 5V.
- Since the wiring length between the internal drive circuit and IGBT is short and the impedance of the drive circuit is low, no reverse bias DC source is required.
- Normally, IPM device requires a total of four isolated control power supplies: one for the lower sides and three for the upper sides. However, since this IPM has built-in bootstrap diodes (BSD), isolated power supplies for the upper sides are not needed.

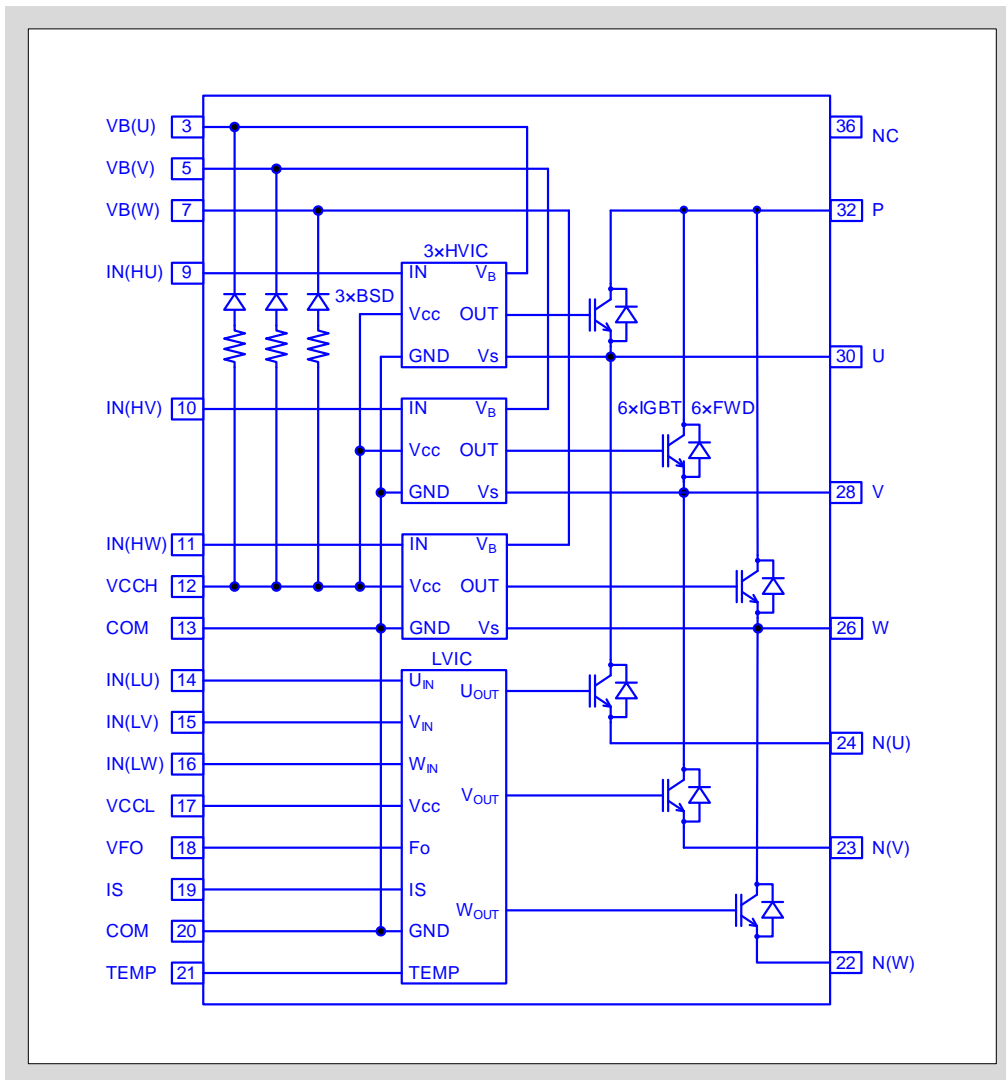

Fig.1-1 Block Diagram of Internal Circuit

<Built-in protection circuits>

- The following built-in protection circuits are incorporated in the product:
 - (OC): Over current protection
 - (UV): Under voltage protection for power supplies of control IC
 - (LT): Temperature sensor output function
 - (OH): Overheating protection (only applied to some products)
 - (FO): Fault alarm signal output
- The OC protection circuits protect the IGBT against over current, load short-circuit or arm short-circuit.
- The protection circuit can monitor the emitter current using external shunt resistor in each lower side IGBT and thus it can protect the IGBT against arm short-circuit.
- The UV protection circuit operates when the control power supply voltage drops below the trip voltage level. It is built into all of the IGBT drive circuits.
- The OH protection circuit protects the product from overheating. The OH protection circuit is built into the control IC of the lower side arm (LVIC).
- The temperature sensor output function is built into the LVIC and converts the detected temperature into analog voltage output.
- The FO function outputs a fault signal when the circuit detects abnormal conditions, thus making it possible to shut down the system reliably and preventing destruction by outputting the fault signal to the microprocessor unit controlling the product.

<Compact package>

- This product uses high heat dissipation aluminum insulated metal substrate (IMS), which improves the heat radiation.
- The control input terminals have a shrink pitch of 1.778mm (70mil).
- The power terminals have a standard pitch of 2.54mm (100mil).

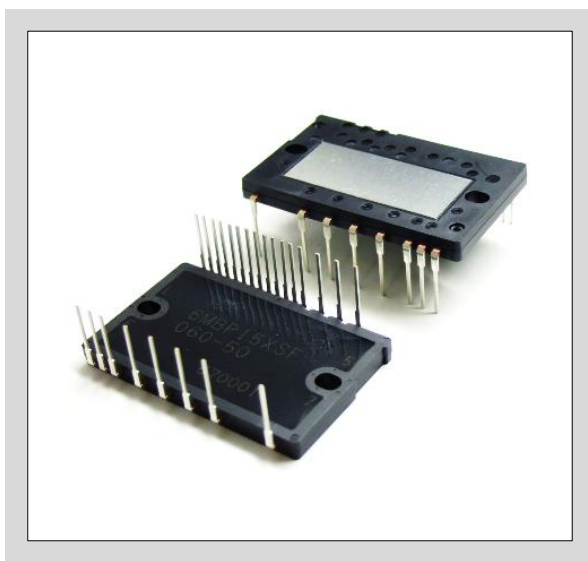

Fig.1-2 Package overview

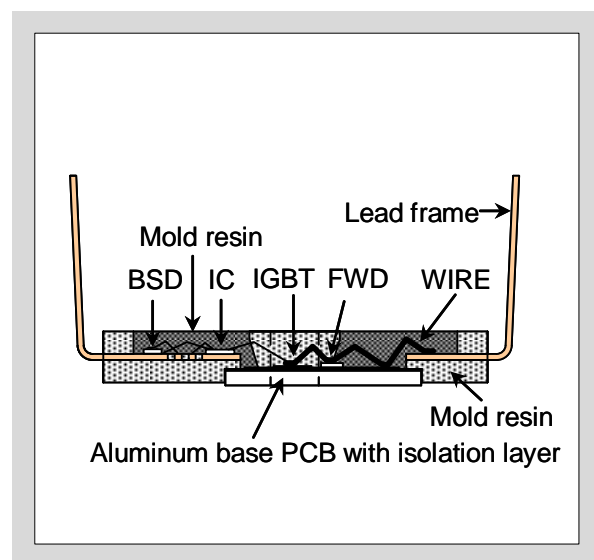

Fig.1-3 Package cross section diagram

2. Product line-up and applicable products for this manual

Table. 1-1 Line-up

Type name	Rating of IGBT		Isolation Voltage [Vrms]	Variation*1
	Voltage [V]	Current [A]		
6MBP15XSD060-50	600	15	1500Vrms Sinusoidal 60Hz, 1min. (Between all shorted terminals and case)	LT
6MBP15XSF060-50				LT OH
6MBP20XSD060-50		20		LT
6MBP20XSF060-50				LT OH
6MBP30XSD060-50		30		LT
6MBP30XSF060-50				LT OH
6MBP35XSD060-50		35		LT
6MBP35XSF060-50				LT OH

*1 LT: Temperature sensor output function
OH: Overheating protection function

3. Definition of Type Name and Marking Spec

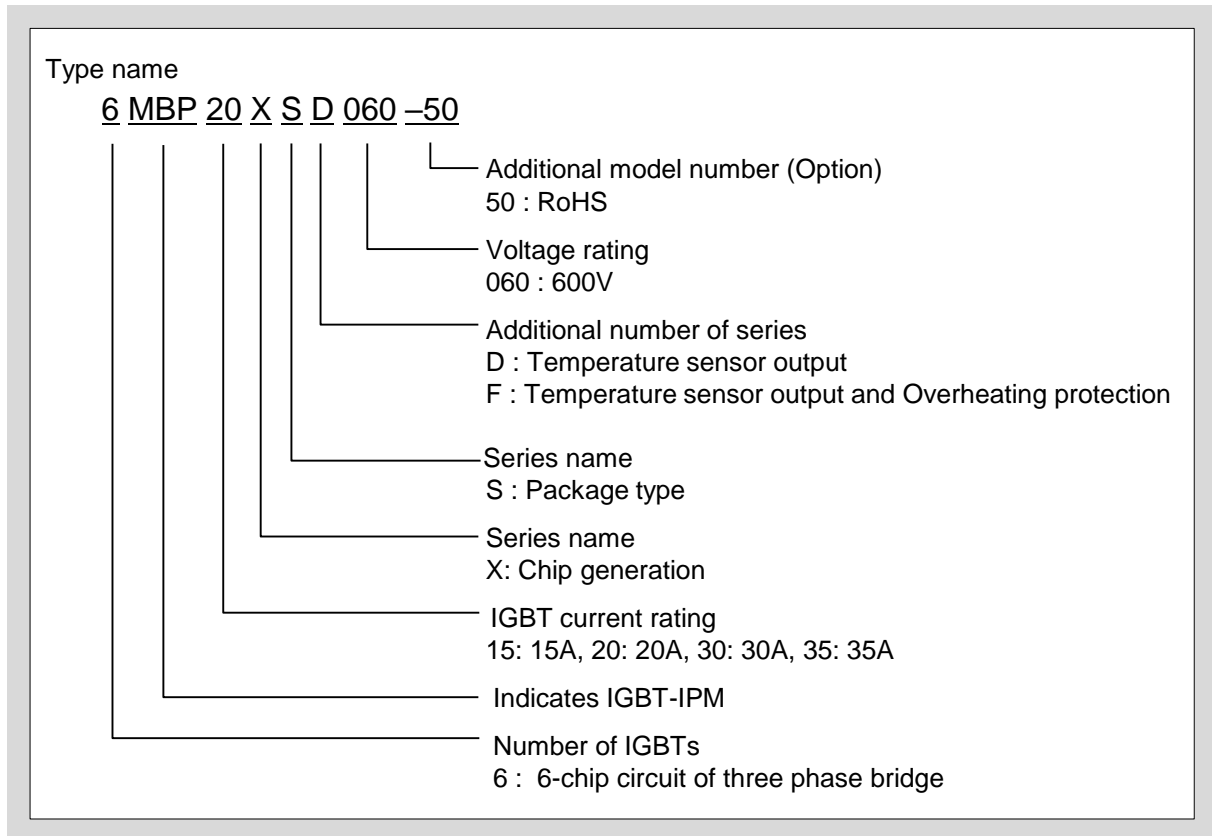

Fig.1-4 Part numbers

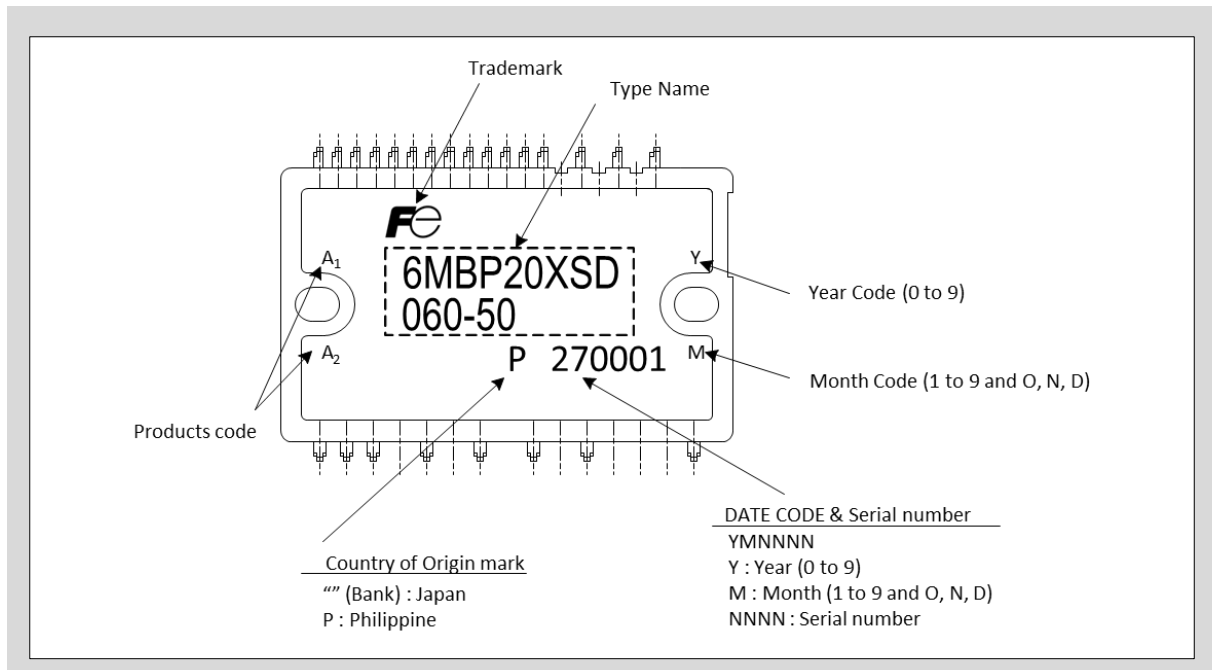

Fig.1-5 Marking Specification

Table. 1-2 Products code

TYPE NAME	PRODUCTS CODE	
	A1	A2
6MBP15XSD060-50	L	D
6MBP15XSF060-50	L	F
6MBP20XSD060-50	M	D
6MBP20XSF060-50	M	F
6MBP30XSD060-50	O	D
6MBP30XSF060-50	O	F
6MBP35XSD060-50	P	D
6MBP35XSF060-50	P	F

4. Package Outline dimensions

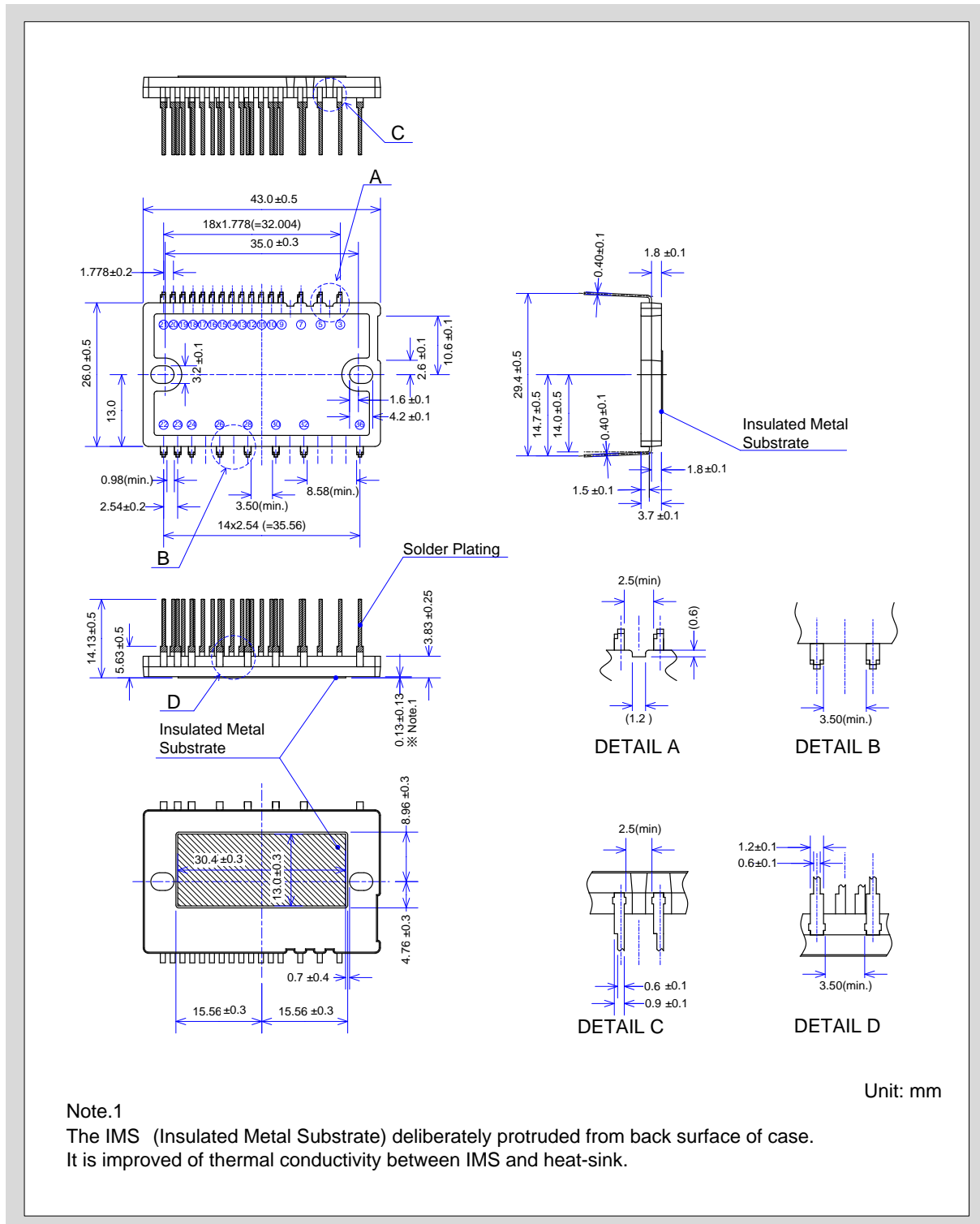

Fig.1-6 Case outline drawings

Table. 1-3 Case outline drawings

Pin No.	Pin Name	Pin No.	Pin Name
3	VB(U)	22	N(W)
5	VB(V)	23	N(V)
7	VB(W)	24	N(U)
9	IN(HU)	26	W
10	IN(HV)	28	V
11	IN(HW)	30	U
12	VCCH	32	P
13	COM	36	NC
14	IN(LU)		
15	IN(LV)		
16	IN(LW)		
17	VCCL		
18	VFO		
19	IS		
20	COM		
21	TEMP		

5. Absolute Maximum Ratings

An example of the absolute maximum ratings of 6MBP20XSD060-50 is shown in Table 1-4.

Table 1-4 Absolute Maximum Ratings at $T_{vj}=25^{\circ}\text{C}$, $V_{CC}=15\text{V}$ (unless otherwise specified)

Item	Symbol	Rating	Unit	Description
DC Bus Voltage	V_{DC}	450	V	DC voltage that can be applied between P-N(U),N(V),N(W) terminals
Bus Voltage (Surge)	$V_{DC(\text{Surge})}$	500	V	Peak value of the surge voltage that can be applied between P-N(U),N(V),N(W) terminals during switching operation
Collector-Emitter Voltage	V_{CES}	600	V	Maximum voltage that can be applied between collector and emitter with V_{IN-COM} shorted
Collector Current	I_C	20	A	Maximum collector current for the IGBT chip $T_c=25^{\circ}\text{C}$, $T_{vj}=150^{\circ}\text{C}$
Peak Collector Current	I_{CP}	40	A	Maximum pulse collector current for the IGBT chip $T_c=25^{\circ}\text{C}$, $T_{vj}=150^{\circ}\text{C}$
Forward Current	I_F	20	A	Maximum forward current for the FWD chip $T_c=25^{\circ}\text{C}$, $T_{vj}=150^{\circ}\text{C}$
Peak Forward Current	I_{FP}	40	A	Maximum pulse forward current for the FWD chip $T_c=25^{\circ}\text{C}$, $T_{vj}=150^{\circ}\text{C}$
Collector Power Dissipation	P_{D_IGBT}	41.0	W	Maximum power dissipation for one IGBT element at $T_c=25^{\circ}\text{C}$, $T_{vj}=150^{\circ}\text{C}$
FWD Power Dissipation	P_{D_FWD}	27.8	W	Maximum power dissipation for one FWD element at $T_c=25^{\circ}\text{C}$, $T_{vj}=150^{\circ}\text{C}$
Virtual Junction Temperature of Inverter Block	T_{vj}	+150	$^{\circ}\text{C}$	Maximum virtual junction temperature of the IGBT chips and the FWD chips. Operating life is limited by junction temperature and power cycle.
Operating Virtual Junction Temperature of Inverter Block	T_{vjOP}	-40 ~ +150	$^{\circ}\text{C}$	Junction temperature of the IGBT and FWD chips during continuous operation. Operating life is limited by junction temperature and power cycle.

Table 1-5 Absolute Maximum Ratings at $T_{vj}=25^{\circ}\text{C}$, $V_{CC}=15\text{V}$ (Continued)

Item	Symbol	Rating	Unit	Descriptions
High-side Supply Voltage	V_{CCH}	-0.5 ~ 20	V	Voltage that can be applied between COM and V_{CCH} terminal
Low-side Supply Voltage	V_{CCL}	-0.5 ~ 20	V	Voltage that can be applied between COM and V_{CCL} terminal
High-side Bias Absolute Voltage	$V_{B(U)-COM}$ $V_{B(V)-COM}$ $V_{B(W)-COM}$	-0.5 ~ 620	V	Voltage that can be applied between $VB(U)-COM$, $VB(V)-COM$, $VB(W)-COM$ terminal
High-side Bias Voltage for IGBT Gate Driving	$V_{B(U)}$ $V_{B(V)}$ $V_{B(W)}$	20	V	Voltage that can be applied between U- $VB(U)$, V- $VB(V)$, W- $VB(W)$ terminal
Input Signal Voltage	V_{IN}	-0.5 ~ $V_{CCH}+0.5$ -0.5 ~ $V_{CCL}+0.5$	V	Voltage that can be applied between $IN(*)-COM$ terminal
Input Signal Current	I_{IN}	3	mA	Maximum input current that flows from $IN(*)$ to COM terminal
Fault Signal Voltage	V_{FO}	-0.5 ~ $V_{CCL}+0.5$	V	Voltage that can be applied between COM and V_{FO} terminal
Fault Signal Current	I_{FO}	1	mA	Sink current that flows from V_{FO} to COM terminal
Over Current Sensing Input Voltage	V_{IS}	-0.5 ~ $V_{CCL}+0.5$	V	Voltage that can be applied between IS and COM terminal
Maximum Junction Temperature of Control Circuit Block	T_{vj}	+150	$^{\circ}\text{C}$	Maximum junction temperature of the control circuit block
Operating Case Temperature	T_c	-40 ~ +125	$^{\circ}\text{C}$	Operating case temperature (temperature of the aluminum plate directly under the IGBT or the FWD)
Storage Temperature	T_{stg}	-40 ~ +125	$^{\circ}\text{C}$	Range of ambient temperature for storage or transportation, when there is no electrical load
Isolation Voltage	V_{iso}	AC 1500	Vrms	Maximum effective value of the sine-wave voltage between the terminals and the heat sink, when all terminals are shorted simultaneously. (Sine wave = 60Hz / 1min)

<Absolute Maximum Rating of Collector-Emitter Voltage>

During operation of the Small IPM, the voltage between P-N(U, V, W) is usually applied to one phase of upper or lower side IGBT. Therefore, the voltage applied between P-N(U, V, W) must not exceed the absolute maximum ratings of IGBT.

- V_{CES} : Absolute Maximum rating of IGBT Collector-Emitter Voltage.
- V_{DC} : DC bus voltage applied between P-N(U, V, W) .
- $V_{DC(Surge)}$: The total of DC bus voltage and surge voltage generated by the wiring (or pattern) inductance between P-N(U, V, W) terminal and bulk capacitor.

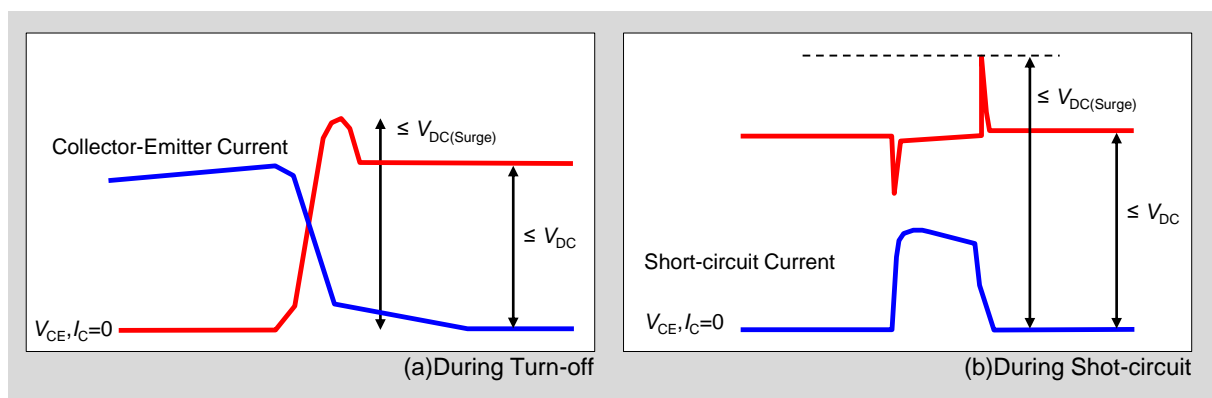

Fig. 1-7 Collector-Emitter voltage

Fig. 1-7 shows example of (a) turn-off and (b) short-circuit waveforms.

The $V_{DC(surge)}$ is different in each situation, therefore V_{DC} should be set considering these situations.

V_{CES} represents the absolute maximum rating of IGBT Collector-Emitter voltage.

$V_{DC(Surge)}$ is specified considering the margin of the surge voltage generated by wiring inductance.

V_{DC} is specified considering the margin of the surge voltage generated by wiring (or pattern) stray inductance between the P-N(U, V, W) terminal and bulk capacitor.