

Evaluation Driver Board for AT-NPC 3-level 4in1 IGBT module



November 2014

Device application Technology Dept.

Semiconductor Div.

Sales Group

Fuji Electric co.,Ltd

Introduction

■ Summary

This evaluation board is used to drive the AT-NPC 3-level 4in1 module. The board includes DC/DC converters, signal I/O connectors and the main I/O terminals. The IGBT&RB-IGBT are driven by the control signal obtained by supplying 15V from an external source.

■ Feature

- 1) The board includes a DC/DC converter.
Gate drive is possible with a single 15V power supply.
- 2) The input are CMOS TTL compatible and can be driven by a 5V signal.
- 3) The gate driver can drive up to 2 modules in parallel.
- 4) The board also features a check pin for IGBT gate voltage conformation.
- 5) The conventional IGBTs of the 4in1 module have a Short circuit protection function built in. (Feature unavailable for RB-IGBTs)

■ IGBT Modules

4MBI300VG-120R-50

4MBI400VF-120R-50

4MBI400VG-060R-50

■ Warning/Notes/Caution

- 1) The driver board has been developed for evaluation purposes only, and does not have any commercial value.
- 2) This application note does not ensure to enforce the industrial property and other rights, such as license rights and license the enforcement rights.
- 3) The component values in this design are intended to aid in your design. Standard variations and operating environment induced variations are not taken into account. It is strongly advised that you verify and account for these variations.

■ Board Dimensions

30mm × 38mm(L × W)

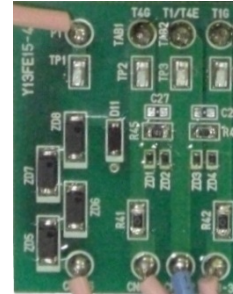

39mm × 38mm(L × W)

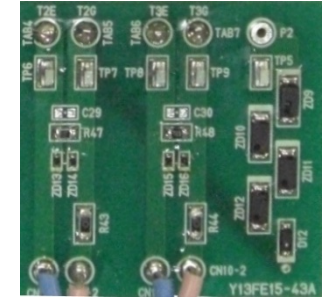

165mm × 100mm(L × W)

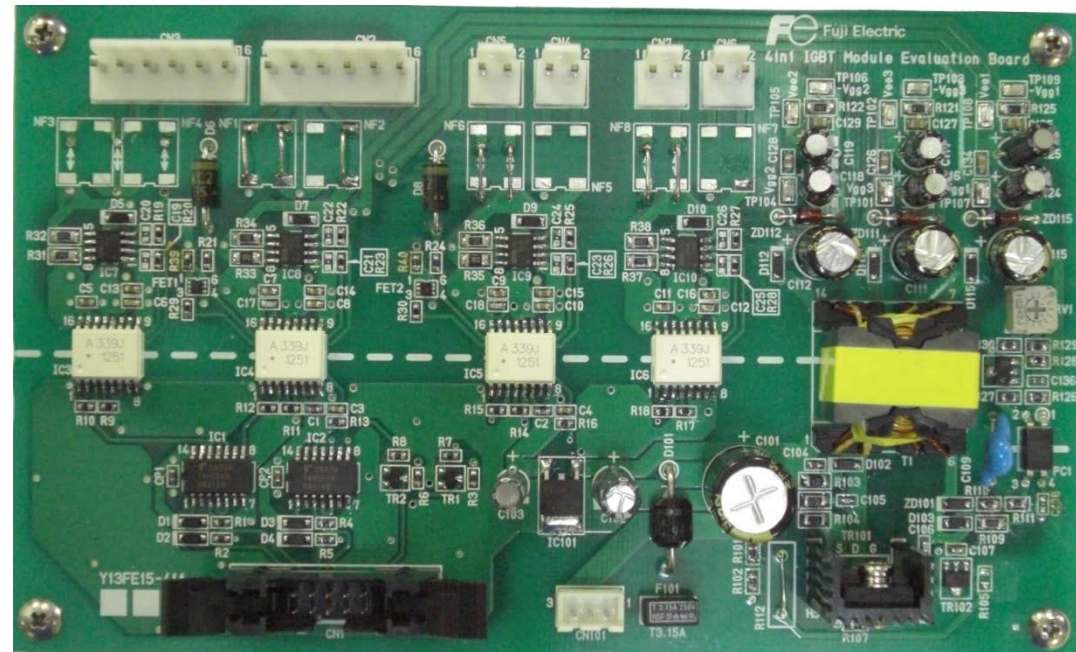

Electrical characteristics

Parameter		Value	Unit	Remarks
VDC(in)	Primary DC/DC voltage supply range	10~18	V	Recommended value 15V
Vout1	Output voltage from DC/DC voltage	+15/-10	V	For IGBT drive supply
Vout2	Primary side control voltage	5	V	Non-isolation
Iout(DC)	DC output current	0.15	A	per 1 output. IGBT drive supply
Iout(peak)	Peak output current (t=1us)	10	A	per 2 output. IGBT drive supply
VLogicIN	PWM signals for High,low side IGBT and RB-IGBT	0/+5	V	Follow the specification of TC74HC04AF
VFAULT	FAULT detection output	0/+5	V	Follow the specification of ACPL-339J
IFault	FAULT detection output load current	8	mA	Follow the specification of ACPL-339J
Vout	IGBT drive voltage level for high, low side	+15/-10	V	
IG	MAX. peak output current	±5.5	A	Follow the specification of ACPL-339J
Pout	MAX. output power	1200	mW	Follow the specification of ACPL-339J
fsw	MAX. PWM signal frequency	35	kHz	single drive condition
		17.5	kHz	pallarel drive condition
tPDELAY	propagation delay time	250	ns	
tPDISTO	input to output propagation distortion	25	ns	
dmax	MAX. duty cycle	100	%	
VCES(IGBT)	MAX. collector-emitter voltage on IGBT	1200	V	4MBI300VG-120R-50
		600	V	4MBI400VG-060R-50
VCES(RB-IGBT)	MAX. collector-emitter voltage on RB-IGBT	600	V	
Top	operateing temperature design target	-10~50	deg	
Tstg	Storage temperature design target	-30~80	deg	

Note: Other specifications follow specifications of TC74HC04AF and ACPL-339J

I/O explanation of the evaluation board

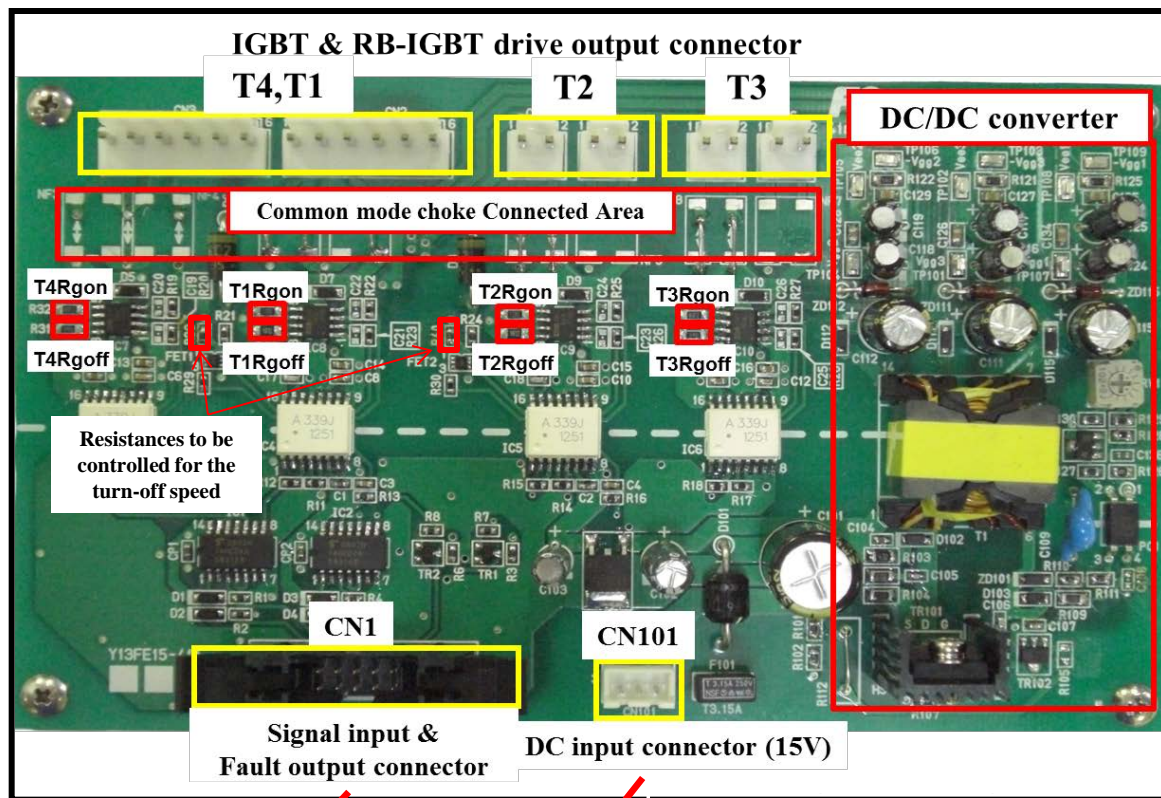

Input and output for connector(CN1)

PIN	
1	PWM signal for high side IGBT(T1)
2	PWM signal for RB-IGBT(T4)
3	PWM signal for RB-IGBT(T3)
4	PWM signal for low side IGBT(T2)
5	GND
6	GND
7	GND
8	GND
9	GND
10	Fault detection output IGBT (T1,T2)

The connector is a XG4M-1030-T(omron) or equivalent.

Input for DC/DC converter connector(CN101)

PIN		
1	VDC	15V
2	NC	
3	GND	0V

The connector is a XHP-3(JST) or equivalent.

Initial value

	Rgon(Ω)	Rgoff(Ω)
T1,T2	10	1
T3,T4	8.2	39

- For a single module drive, please use a through hole to short the pattern in the common mode choke connected area.
- Please attach this board only when performing a parallel drive in the common mode choke. Common mode choke is not connected initially.
- Please adjust the Rgon, Rgoff as required by circuit conditions, the initial suggested values are shown in the table to the left.

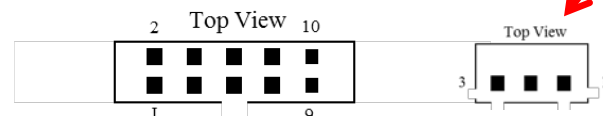

Connector connection

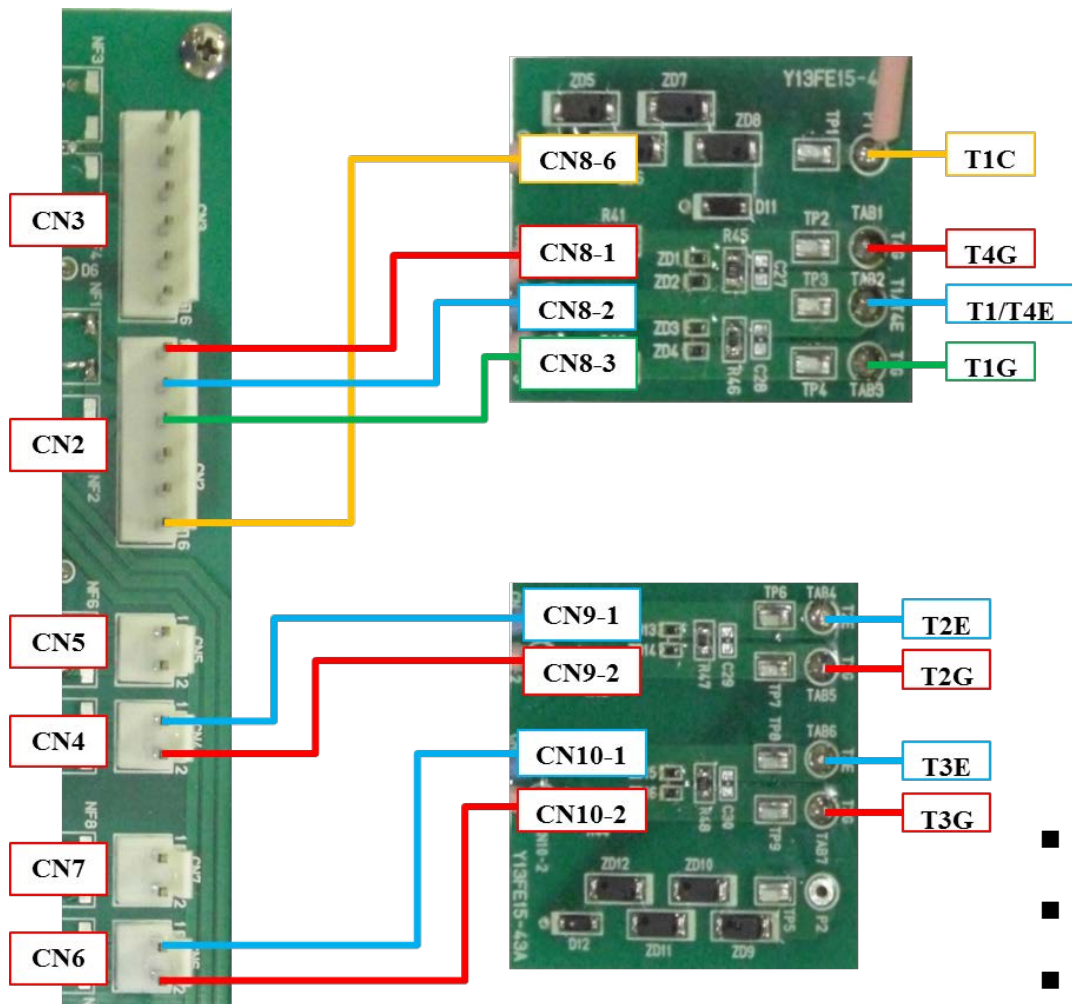

Top View



Output for IGBT and RB-IGBT drive connector (CN2, CN3)

PIN	Remarks
1	RB-IGBT Gate(T4G) connect to CN8-1
2	high side IGBT and RB-IGBT Emitter(T1/T4E) connect to CN8-2
3	high side IGBT Gate(T1G) connect to CN8-3
4	NC
5	NC
6	high side IGBT Collector(T1C) connect to CN8-6

The connector is a VHR-6N(JST) or equivalent

Top View



Output for IGBT drive connector (CN4, CN5)

PIN	Remarks
1	low side IGBT Emitter(T2E) connect to CN9-1
2	low side IGBT Gate(T2G) connect to CN9-2

Output for RB-IGBT drive connector (CN6, CN7)

PIN	Remarks
1	RB-IGBT Emitter(T3E) connect to CN10-1
2	RB-IGBT Gate(T3G) connect to CN10-2

The connector is a VHR-2N(JST) or equivalent

- Connect CN8-1, CN8-2, CN8-3 and CN8-6 on the sub board to CN2. **Don't use CN3 when single module driving.**
- Connect CN9-1 and CN9-2 on the sub board to CN4. CN5 can be used instead of CN4 even if single if single module driving.
- Connect CN10-1 and CN10-2 on the sub board to CN6. CN7 can be used instead of CN6 even if single if single module driving.
- Connect T1C on the sub board to T1 collector terminal as shown in page 6. **Don't operate the IGBT without connecting T1C and T1 collector terminal.**

GDU sub circuit board

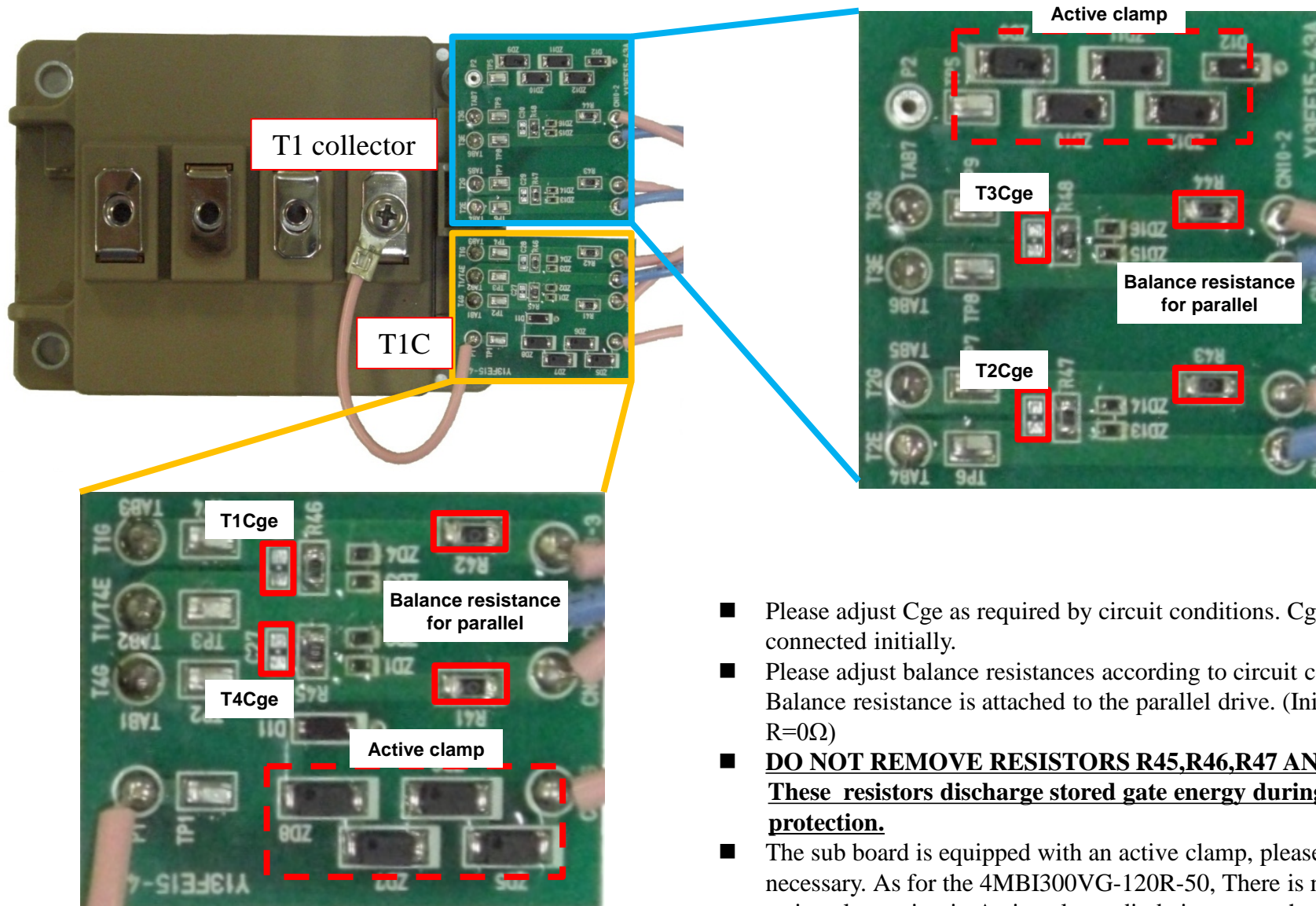

- Please adjust Cge as required by circuit conditions. Cge is not connected initially.
- Please adjust balance resistances according to circuit conditions. Balance resistance is attached to the parallel drive. (Initial value: $R=0\Omega$)
- **DO NOT REMOVE RESISTORS R45,R46,R47 AND R48.** **These resistors discharge stored gate energy during short circuit protection.**
- The sub board is equipped with an active clamp, please use if deemed necessary. As for the 4MBI300VG-120R-50, There is no need for active clamp circuit. Active clamp diode is not attached initially.

GDU & IGBT module connection (1 phase)

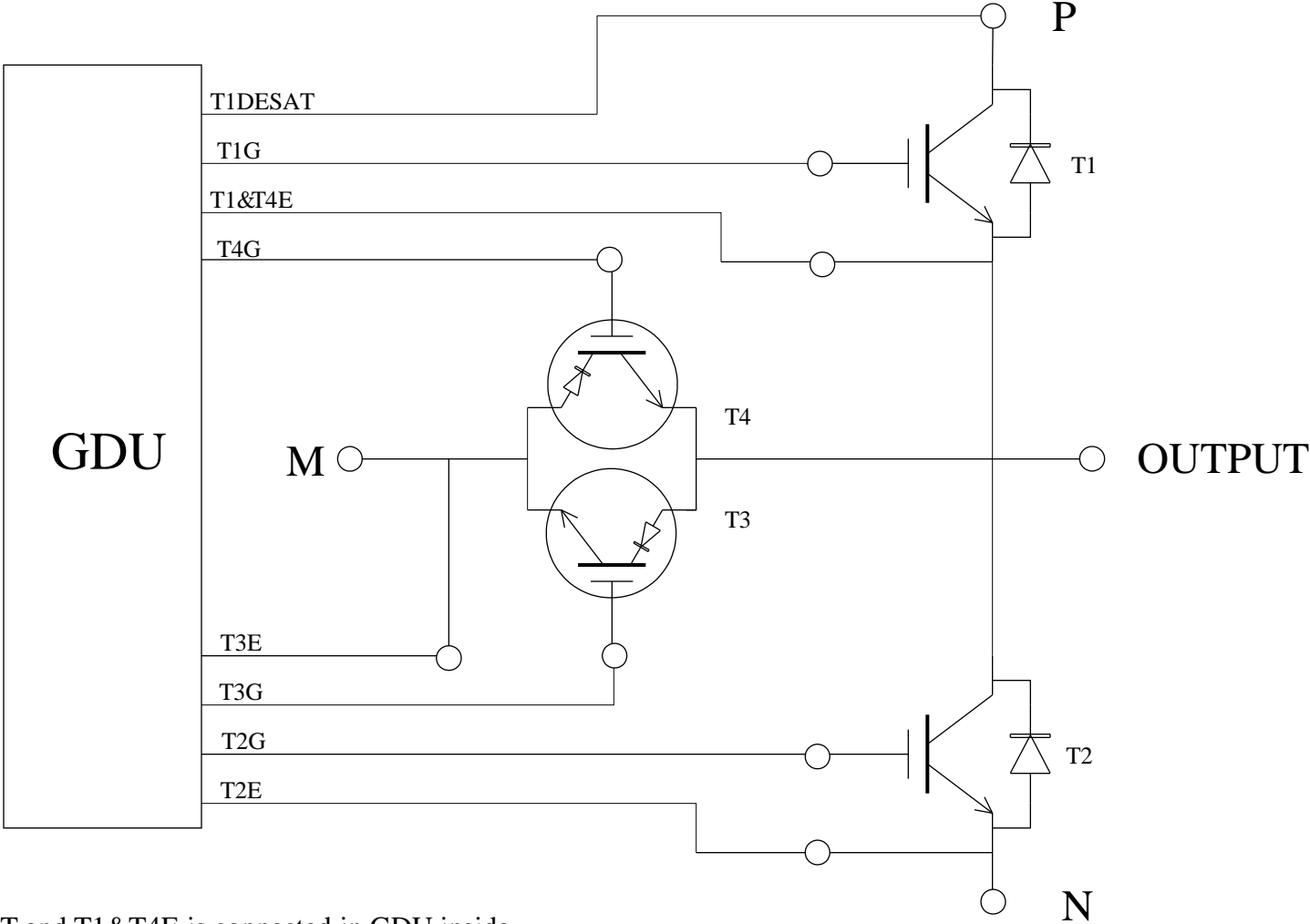

T2DESAT and T1&T4E is connected in GDU inside

Operation of AT-NPC 3-level IGBT module

SW mode	A	B	A	B
T1	SW	OFF	OFF	OFF
T2	OFF	OFF	SW	OFF
T3	OFF	SW	ON	ON
T4	ON	ON	OFF	SW

SW: Connect to drive circuit and input gate signal
 ON: Bias voltage of gate +15V
 OFF: Reverse bias voltage of gate -10V
 $V_{cc2} = V_{cc1}/2$

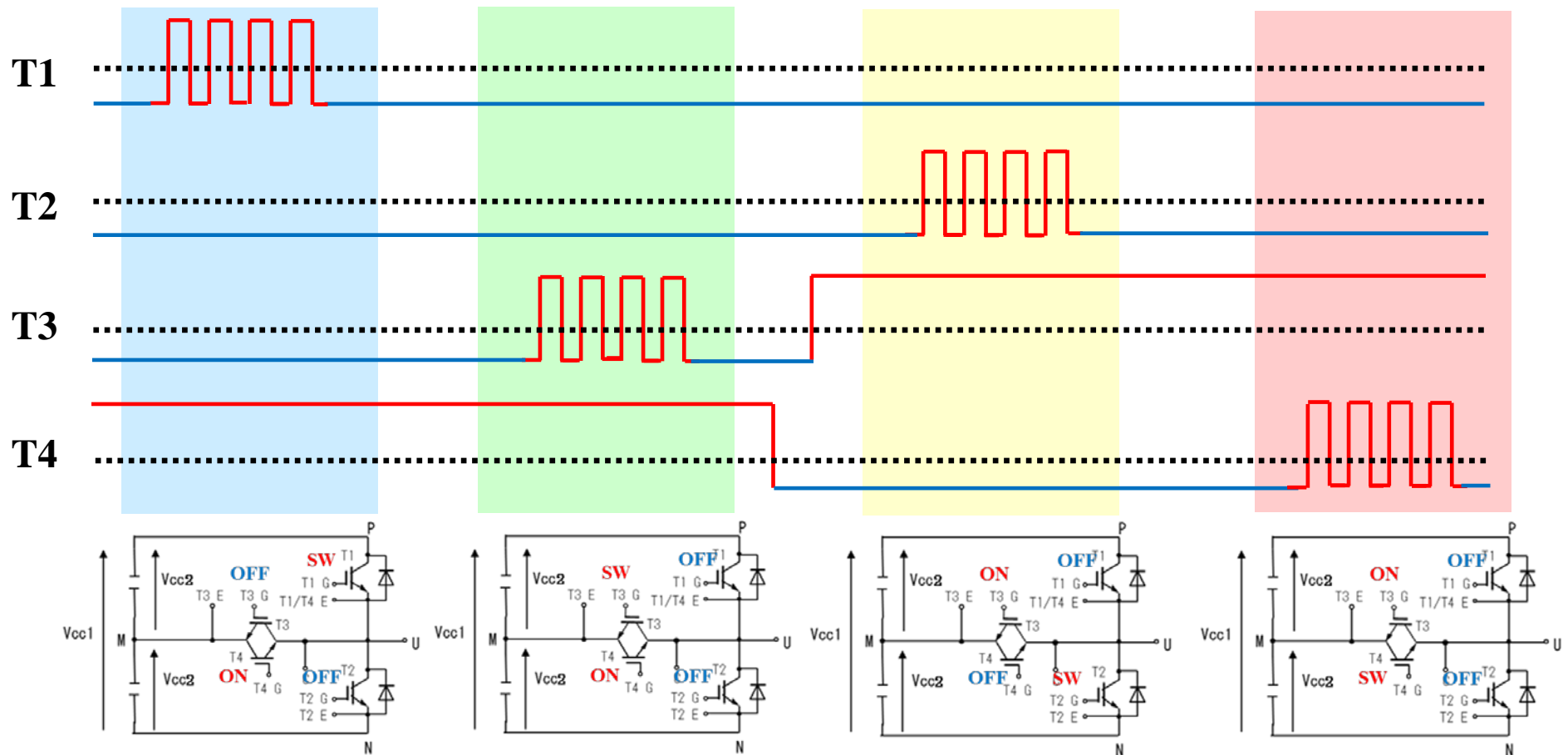

Conversion circuit example from 2-level signal to 3-level signal

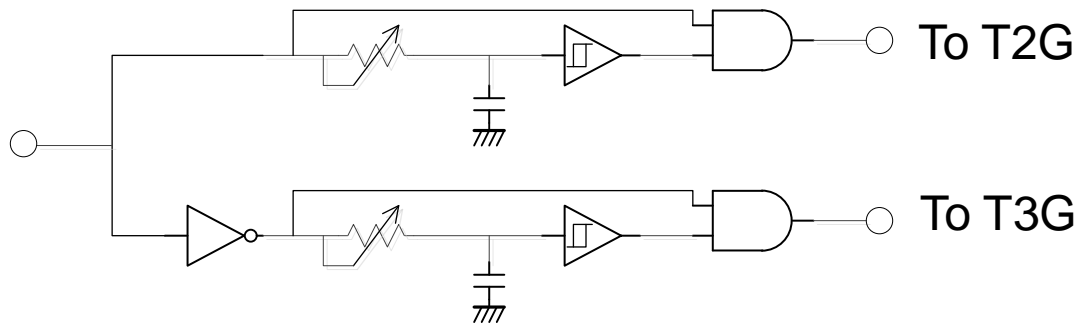
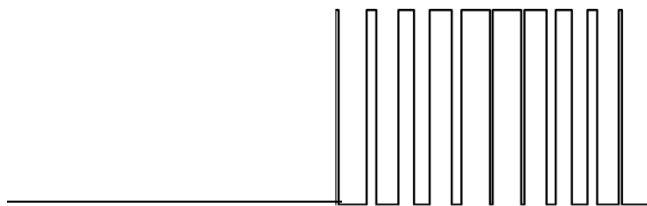
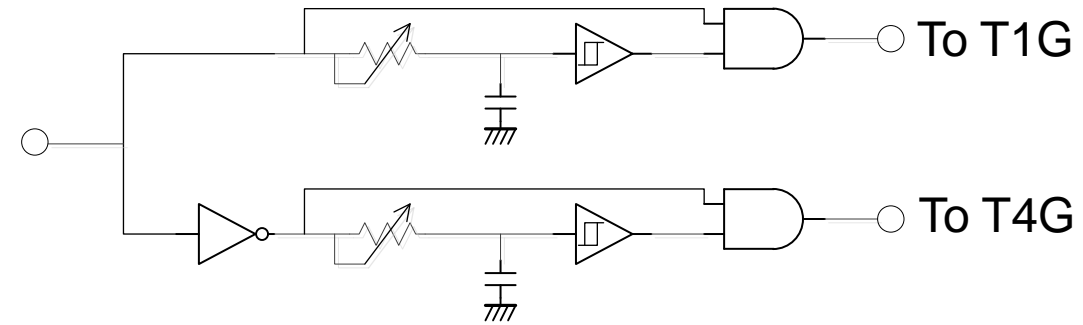
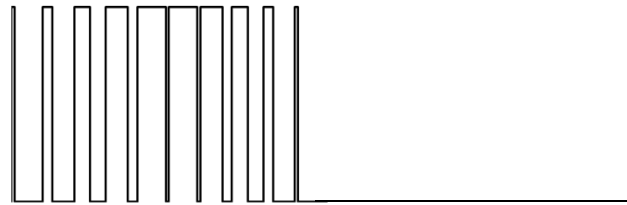
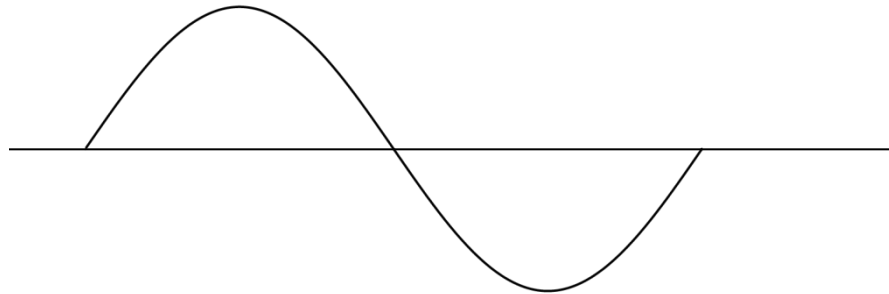

Switching waveform of main IGBT(A-mode)

Module: 4MBI300VG-120R-50

Measured conditions: $V_{cc2}=400V$, $I_c=300A$, $T_j=125^{\circ}C$, $V_{GE}=+15V/-10V$

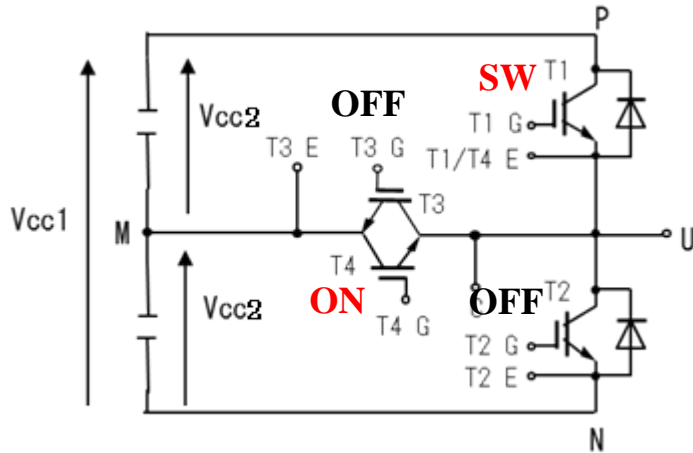

Initial value

	Rgon(Ω)	Rgoff(Ω)
T1,T2	10	1
T3,T4	8.2	39

SW mode	Load L	T1	T2	T3	T4
A	M-U	SW	OFF	OFF	ON
	M-U	OFF	SW	ON	OFF
B	P-U	OFF	OFF	SW	ON
	U-N	OFF	OFF	ON	SW

SW: Connect to drive circuit and input gate signal
 ON: Bias voltage of gate +15V
 OFF: Reverse bias voltage of gate -10V
 $V_{cc2}=V_{cc1}/2$

ton

toff

trr

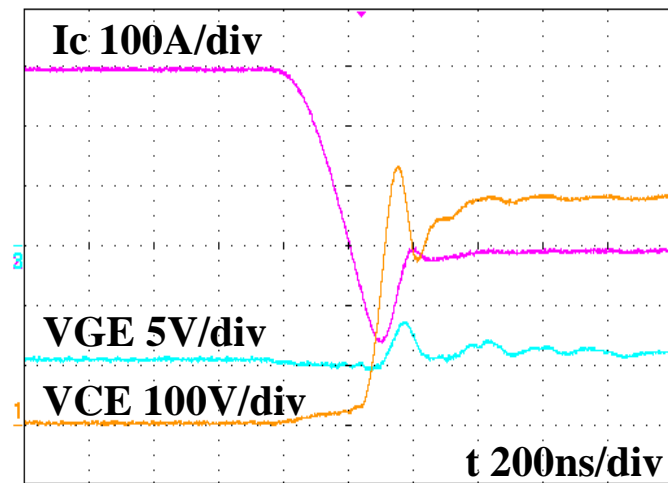
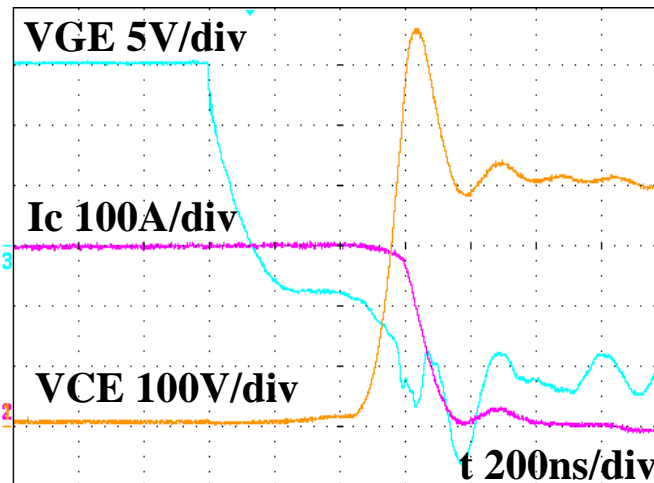
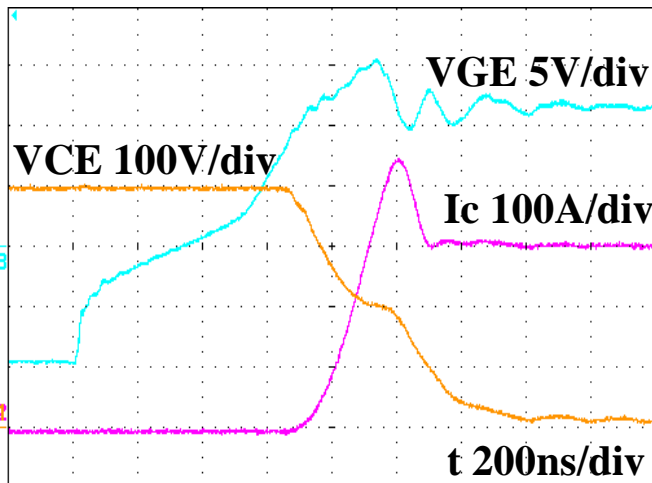

Switching waveform of RB-IGBT(B-mode)

Module: 4MBI300VG-120R-50

Measured conditions: $V_{cc2}=400V$, $I_c=300A$, $T_j=125^\circ C$, $V_{GE}=+15V/-10V$

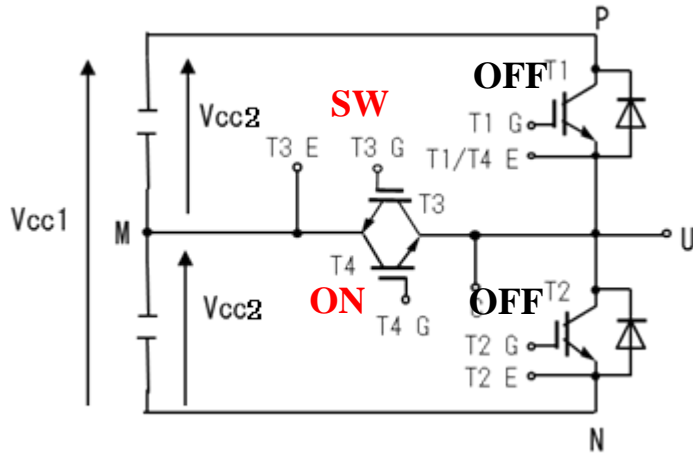

Initial value

	Rgon(Ω)	Rgoff(Ω)
T1,T2	10	1
T3,T4	8.2	39

SW mode	Load L	T1	T2	T3	T4
A	M-U	SW	OFF	OFF	ON
	M-U	OFF	SW	ON	OFF
B	P-U	OFF	OFF	SW	ON
	U-N	OFF	OFF	ON	SW

SW: Connect to drive circuit and input gate signal
 ON: Bias voltage of gate +15V
 OFF: Reverse bias voltage of gate -10V
 $V_{cc2}=V_{cc1}/2$

ton

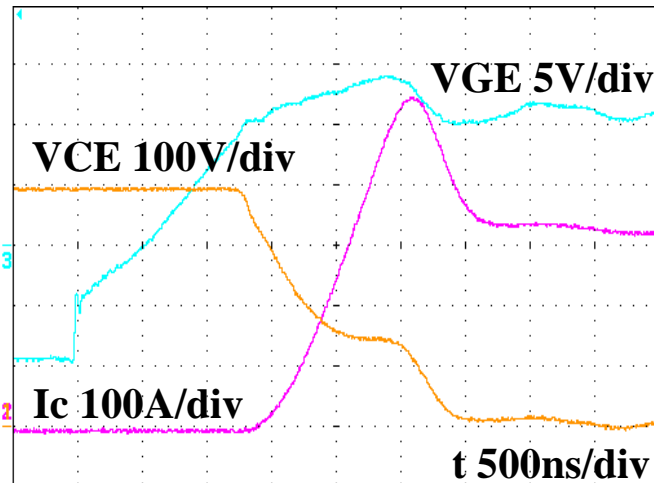

toff

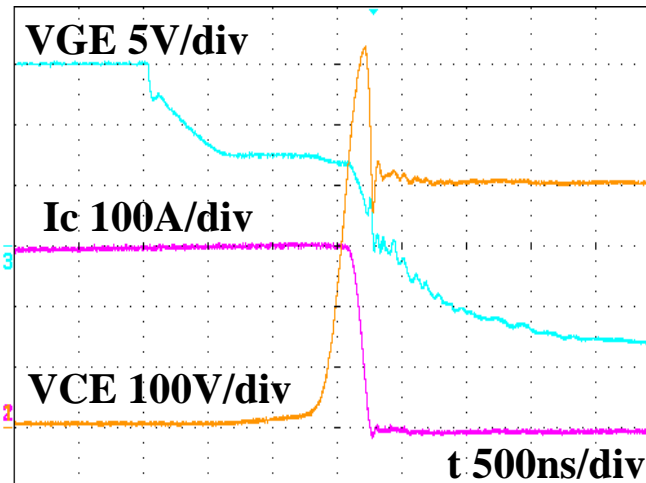

trr

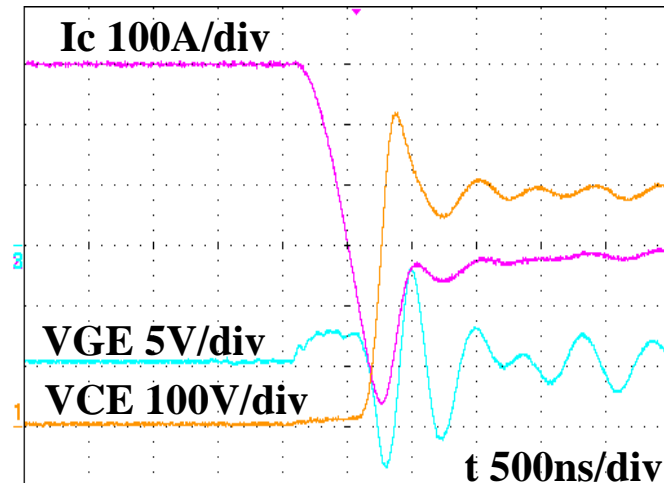

Short circuit protection

Module: 4MBI300VG-120R-50

Measured conditions: $V_{cc2}=400V$, $T_j=125^{\circ}C$, $V_{GE}=+15V/-10V$

Initial value

	$R_{gon}(\Omega)$	$R_{goff}(\Omega)$
T1,T2	10	1
T3,T4	8.2	39

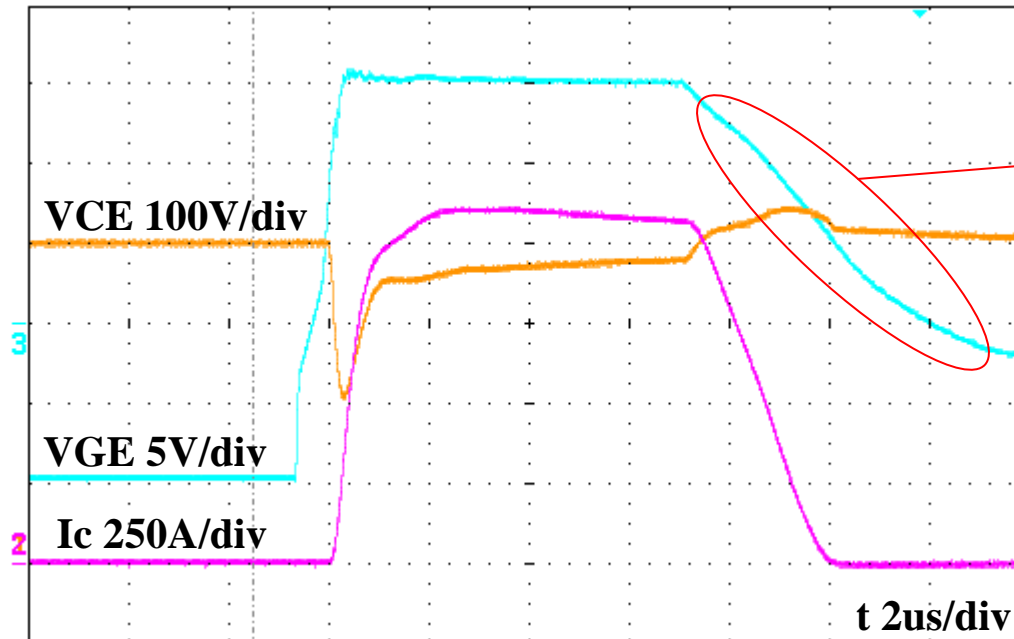

The turn-off speed can be controlled by changing the value of resistances : R46,R47.

The T1 and T2 gate drive circuit has a built-in function of short-circuit protection. The DESAT pin monitors a short circuit. When a DESAT fault is detected, the IGBT is turned off softly. The soft turn-off speed is adjustable by changing the value of resistances R46 and R47. The soft turn-off circuit is different from the typical gate drive circuit on the datasheet of AVAGO ACPL-339J (AV02-3784EN)

FAULT output

Before short circuit detection

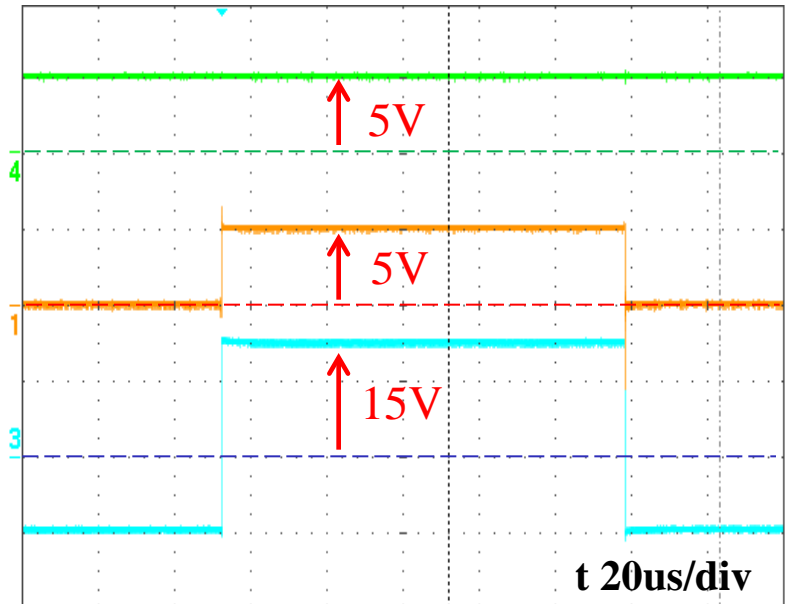

FAULT output
5V/div

Input signal
5V/div

Output signal
10V/div

After short circuit detection

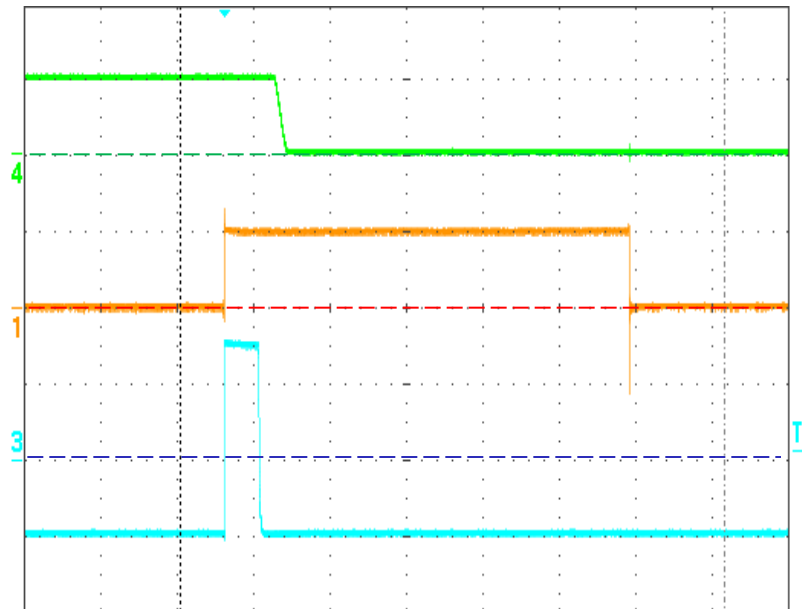

FAULT output, PWM input and IGBT gate-emitter voltage waveforms when a DESAT fault is detected are shown in the above figures.

When the DESAT fault is detected, the IGBT is turned off and FAULT output switches from high to low.

Please refer the data sheet for AVAGO ACPL-339J (AV02-3784EN) for more detail.

Schematic diagram of DC/DC converter circuit

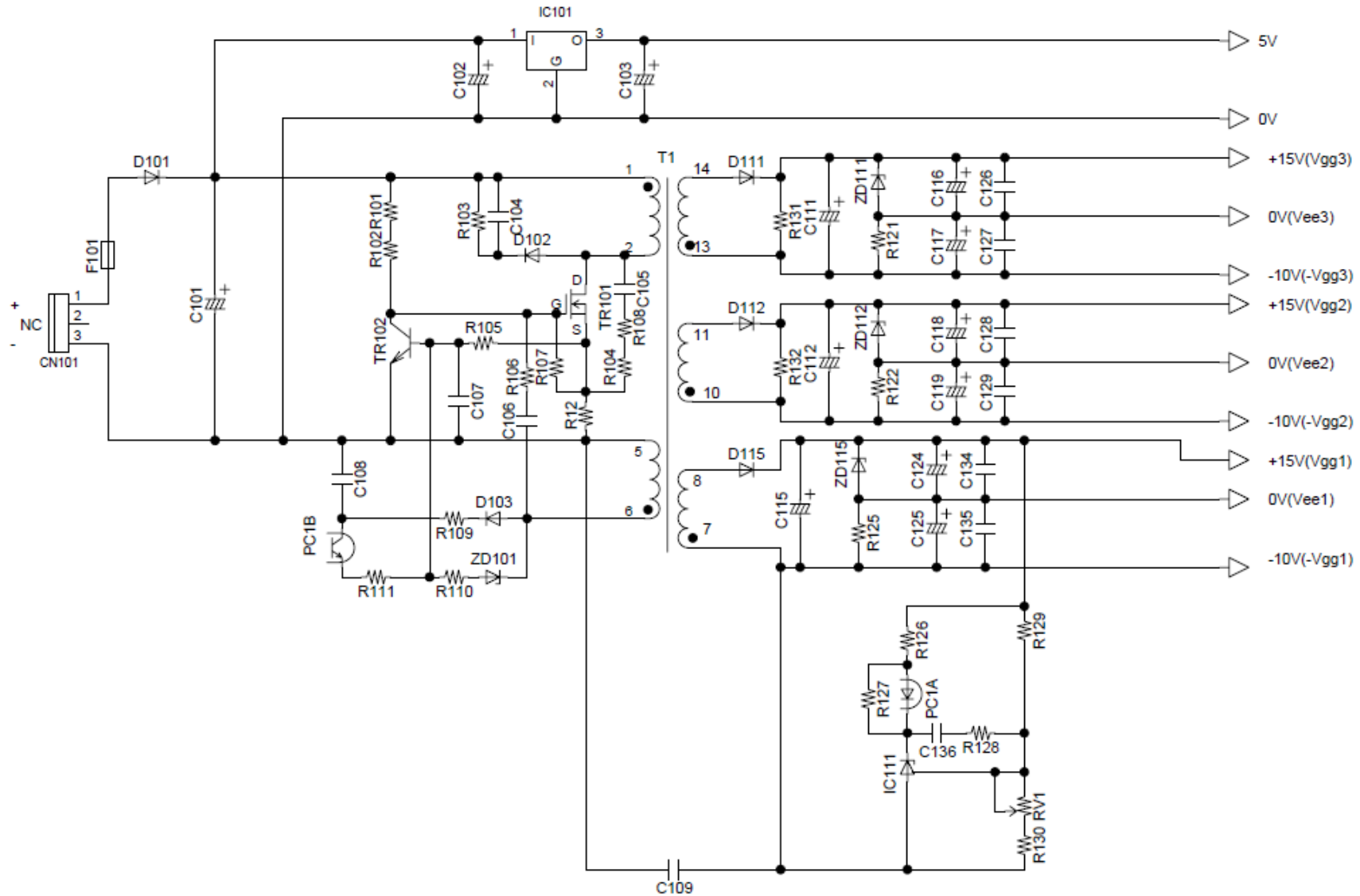

Schematic diagram of GDU sub circuit board

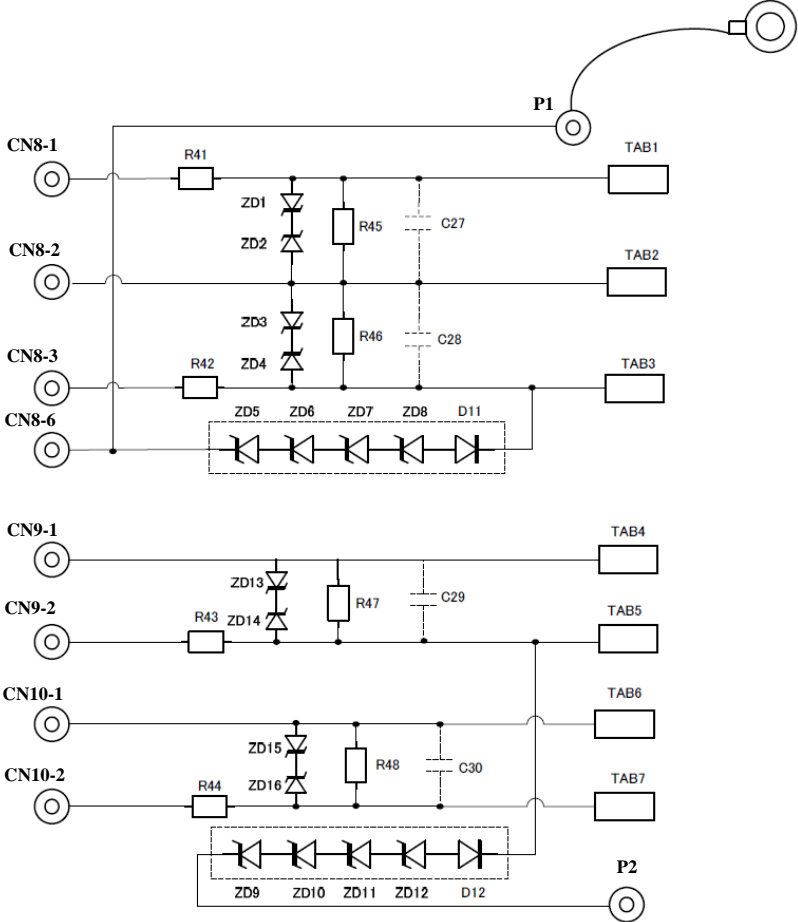

Schematic diagram of GDU main circuit board Fuji Electric Innovating Energy Technology

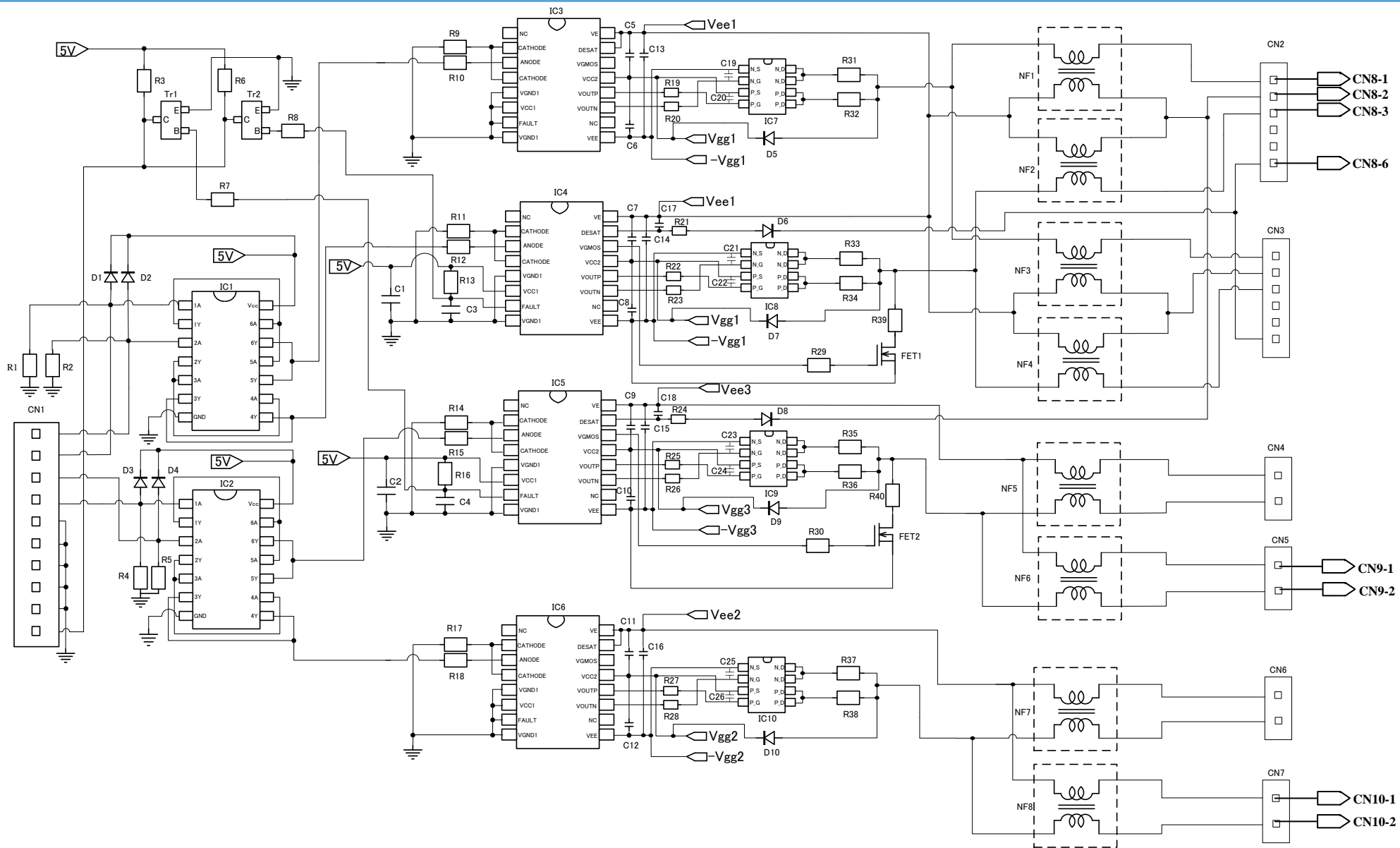

BOM (D/D converter)

Type	Q'ty	Value/Device	Package size	Part Name	Recommended Manufacturer	Assembled	Remarks
Resistor	1	0		R112			Jumper
Resistor	3	10	3216	R104,R108,R109			
Resistor	1	47	3216	R106			
Resistor	1	470	2125	R111			
Resistor	1	1k	2125	R126			
Resistor	3	1.5k	3216	R121,R122,R125			
Resistor	1	2k	2125	R130			
Resistor	1	2.2k	2125	R127			
Resistor	1	3.6k	2125	R110			
Resistor	1	4.7k	2125	R102			
Resistor	1	4.7k	3216	R103			
Resistor	1	8.2k	2125	R101			
Resistor	1	10k	2125	R107			
Resistor	3	22k	2125	R129,R131,R132			
Resistor	1	220k	2125	R128			
Resistor	1	FT63-EP102		RV1			Variable resistance
Capacitor	1	1000pF		C109			
Capacitor	1	1000pF	1608	C105			
Capacitor	2	2200oF, 50V	1608	C106,C107			
Capacitor	2	0.1uF,50V	1608	C104,C136			
Capacitor	6	2.2uF,25V	2125	C126,C127,C128 C129,C134,C135			
Capacitor	6	22uF,50V	5*11	C116,C117,C118, C119,C124,C125			
Capacitor	1	100uF,10V	5*11	C103			
Capacitor	1	100uF,25V	6.3*11	C102			
Capacitor	3	100uF,50V	8*11.5	C111,C112,C115			
Capacitor	1	1500uF,25V	12.5*25	C101			

BOM (D/D converter, GDU sub board)

Type	Q'ty	Value/Device	Package size	Part Name	Recommended Manufacturer	Assembled	Remarks
Diode	1	40V,5A		D101			
Diode	5	200V,1A		D102,D103,D111, D112,D115			
FET	1	2SK3587-01MR		TR101			
transistor	1	2SC2873Y(TE12L,F)		TR102			
Zener diode	1	2.2V		ZD101			
Zener diode	3	15V		ZD111,ZD112,ZD115			
IC	1	TA7805F(TE16L1,NQ)		IC101			
IC	1	TA76431F(TE12L,F)		IC111			
Photocoupler	1	TLP781F(D4-GRF)		PC1			
Fuse	1	SLT250V3.15A		F101			
CONNECTER	1	B3B-XH-A(LF)(SN)		CN101			
TERMINAL	9	HK-2		TP101,TP102,TP103, TP104,TP105,TP106, TP107,TP108,TP109			
Heat sink	1	S19225-BP					
PCB	1	Y13FE16-41B					

Type	Q'ty	Value/Device	Package size	Part Name	Recommended Manufacturer	Assembled	Remarks
Resistor	8	0	3216	R41,R42,R43,R44			
Resistor	8	10K	2125	R45,R46,R47,R48			
Capacitor	8	Cge	1608	C27,C28,C29,C30		no	
Diode	2			D11,D12		no	For active clamp
Zener diode	16	DF2S24F		ZD1,ZD2,ZD3,ZD4,ZD13, ZD14,ZD15,ZD16			
Zener diode	16			ZD5,ZD6,ZD7,ZD8,ZD9, ZD10,ZD11,ZD12		no	For active clamp

BOM (GDU main board)

Type	Q'ty	Value/Device	Package size	Part Name	Recommended Manufacturer	Assembled	Remarks
Resistor	2	1	3216	R33,R35			
Resistor	8	6	1608	R19,R20,R22,R23,R25 R26,R27,R28			
Resistor	2	8.2	3216	R32,R38			
Resistor	2	10	3216	R34,R36			
Resistor	2	39	3216	R31,R37			
Resistor	2	50	1608	R29,R30			
Resistor	2	100	1608	R21,R24			
Resistor	4	143	1608	R9,R11,R14,R17			
Resistor	4	287	1608	R10,R12,R15,R18			
Resistor	2	330	1608	R39,R40			
Resistor	2	4.7K	1608	R3,R6,			
Resistor	6	10K	1608	R1,R2,R4,R5,R13,R16			
Resistor	2	47K	1608	R7,R8			
Capacitor	2	220pF	1608	C17,C18			
Capacitor	2	1nF	1608	C3,C4			
Capacitor	2	0.3uF	1608	C1,C2			
Capacitor	8	1uF	1608	C5,C7,C9,C11,C13,C14, C15,C16			
Capacitor	4	10uF	1608	C6,C8,C10,C12			
Capacitor	8		1608	C19,C20,C21,C22,C23, C24,C25,C26		no	
common mode choke	8	CPFC85NP-WHφ7		NF1,NF2,NF3,NF4,NF5 NF6,NF7,NF8	sumida	no	For 2 paralell conection
Diode	8	CRS12		D1,D2,D3,D4,D5,D7, D9,D10			
Diode	2	RC2		D6,D8			
transistor	2	30V/0.5A		Tr1,Tr2			
IC	2	TC74HC04AF		IC1,IC2			Hex Inverter
IC	4	ACPL-339J-000E		IC3,IC4,IC5,IC6	Avago Technologies		
IC	4	IRF7343		IC7,IC8,IC9,IC10			
FET	2	SSM6K407TU		FET1,FET2			
CONNECTER	1	XG4A-1031		CN1			
CONNECTER	2	B6P-VH		CN2,CN3			
CONNECTER	4	B2P-VH		CN4,CN5,CN6,CN7			
TERMINAL	18	HK-2		TP1,TP2,TP3,TP4,TP5, TP6,TP7,TP8,TP9,			

GDU sub board pattern layouts

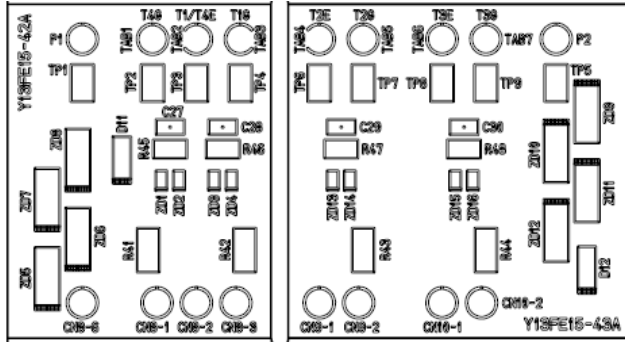

Assembly drawing

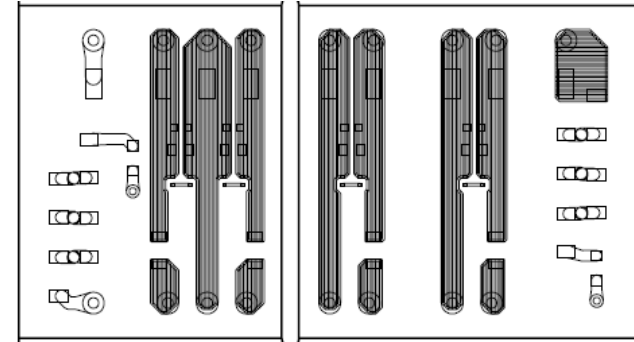

Top layer pattern

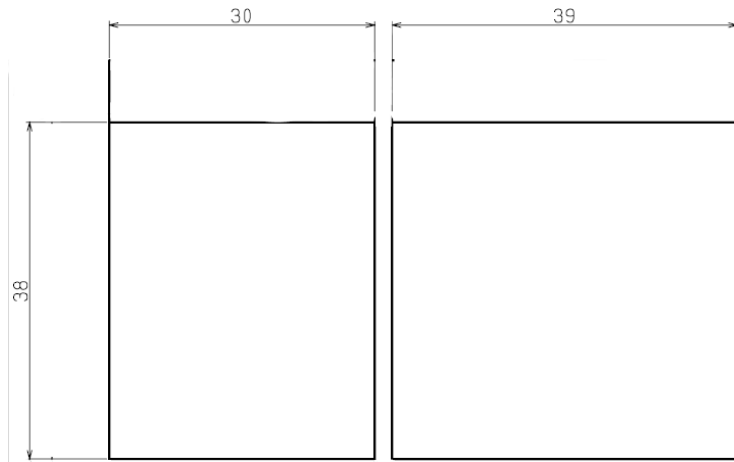

Board dimensions

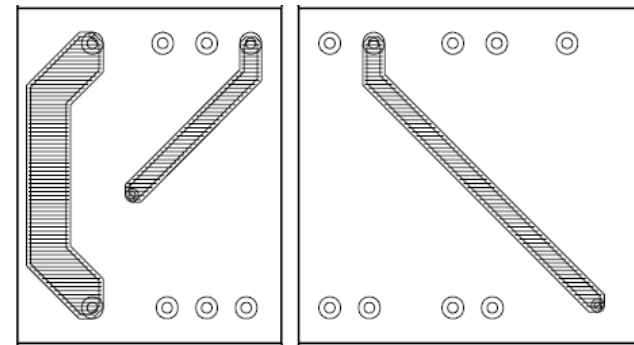

Bottom layer pattern

GDU main board pattern layout 1

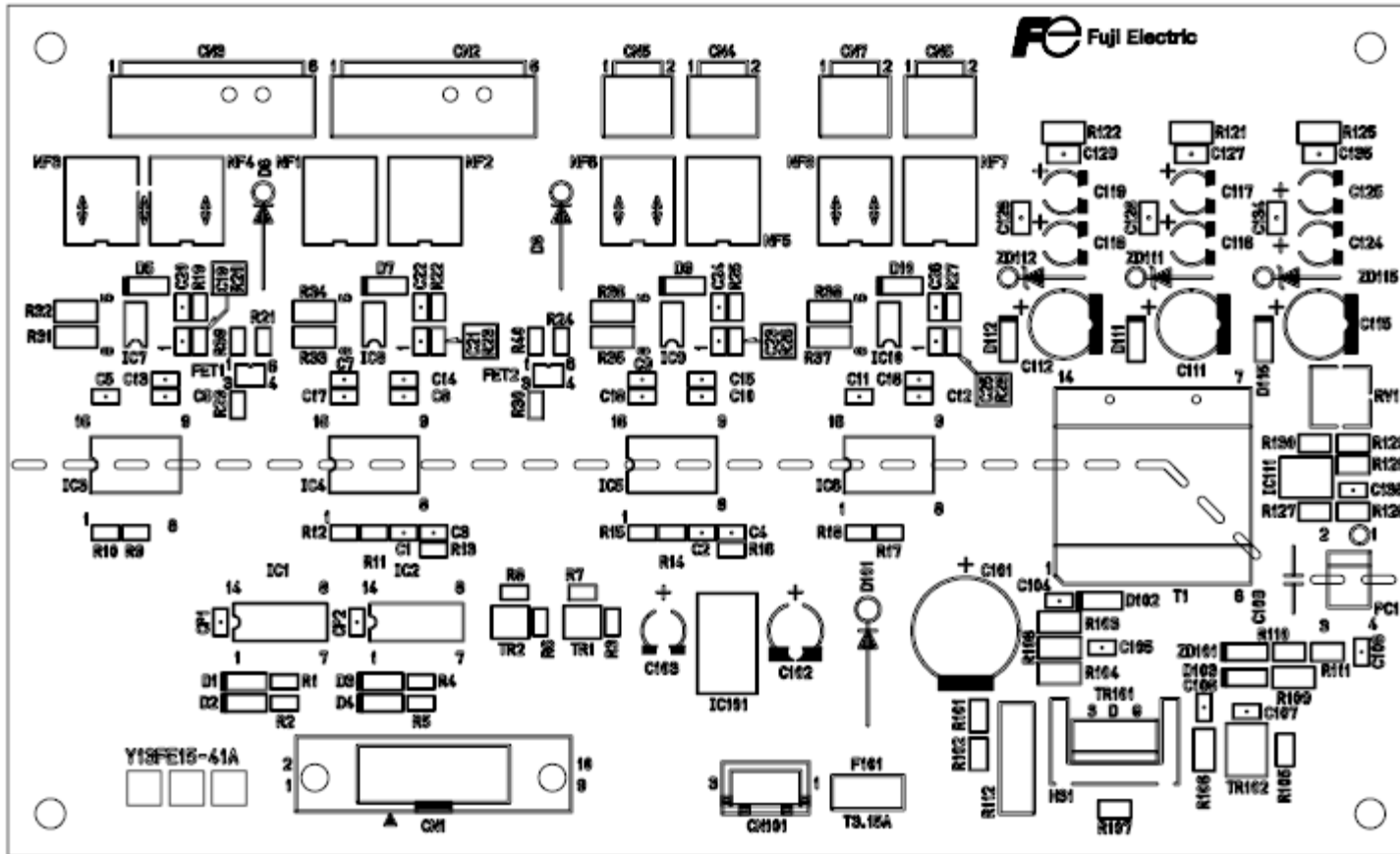

Assembly drawing

GDU main board pattern layout 2

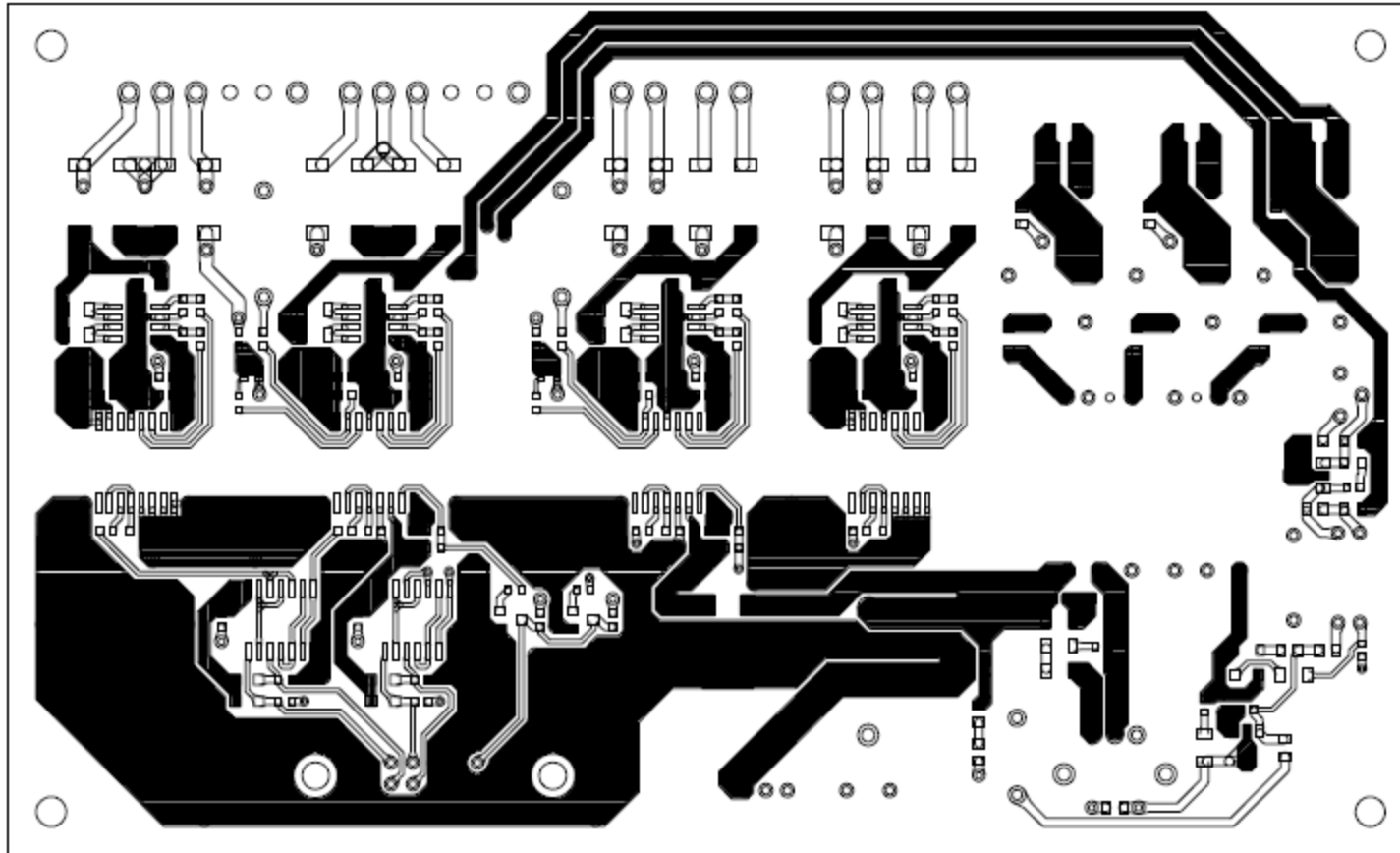

Top layer pattern

GDU main board pattern layout 3

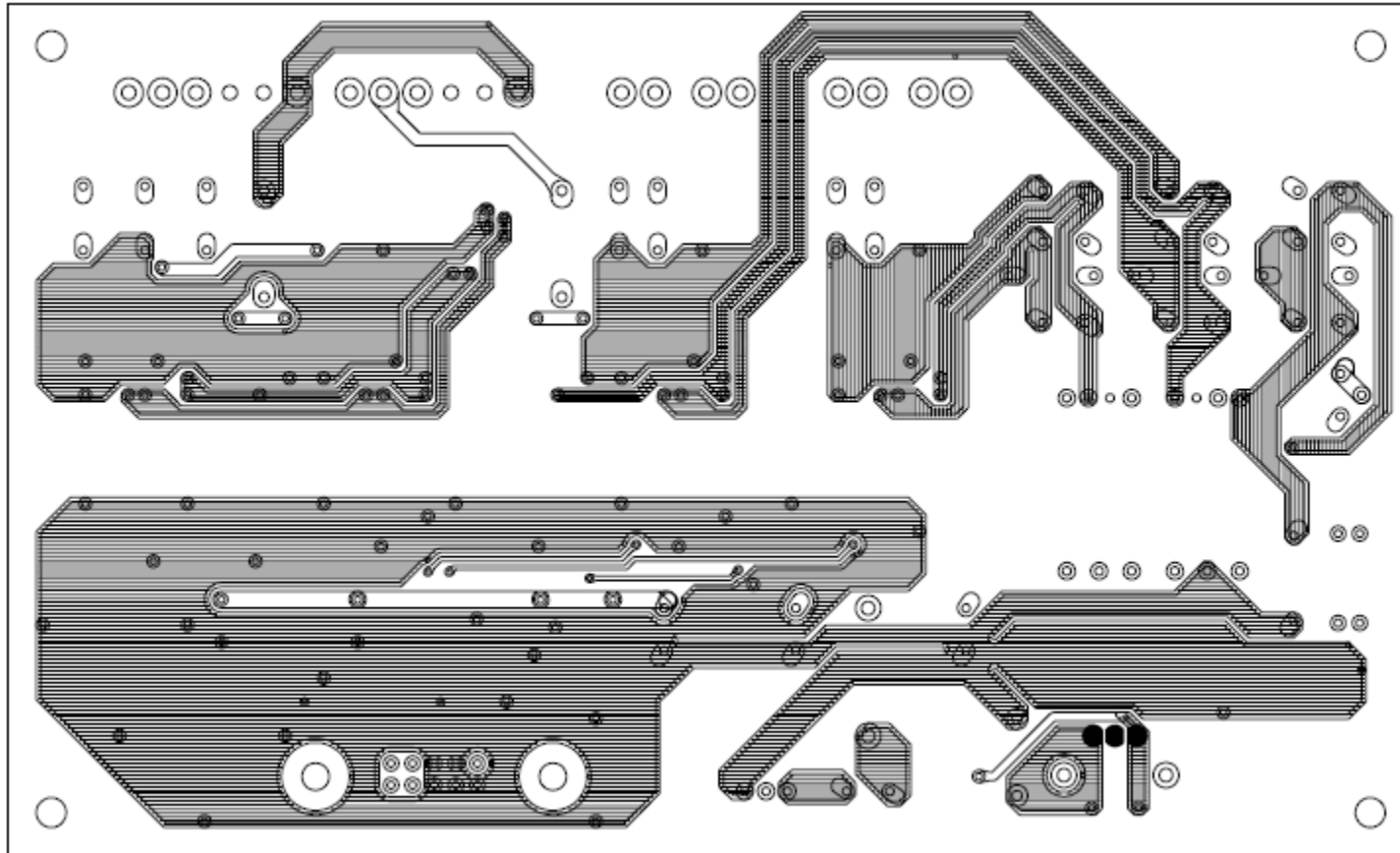

Bottom layer pattern

GDU main board pattern layout 4

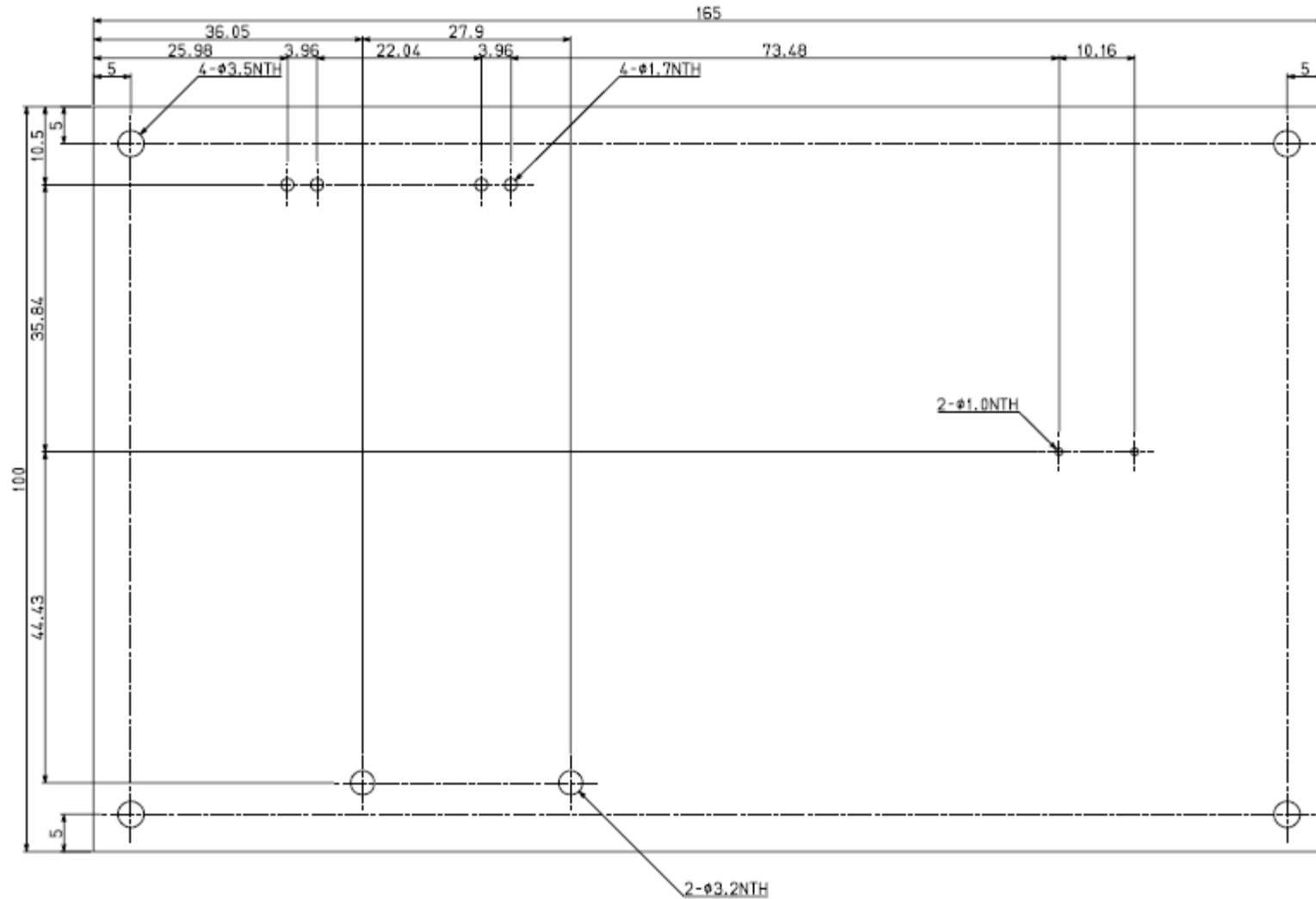

Board dimensions

Unit:mm