

Fuji 7th Generation IGBT-IPM X Series



Application Manual

Warning:

This manual contains the product specifications, characteristics, data, materials, and structures as of October 2021.

The contents are subject to change without notice for specification changes or other reasons. When using a product listed in this manual, be sure to obtain the latest specifications.

All applications described in this manual exemplify the use of Fuji's products for your reference only. No right or license, either express or implied, under any patent, copyright, trade secret or other intellectual property right owned by Fuji Electric Co., Ltd. is (or shall be deemed) granted. Fuji Electric Co., Ltd. makes no representation or warranty, whether express or implied, relating to the infringement or alleged infringement of other's intellectual property rights which may arise from the use of the applications described herein.

Cautions

(1) During transportation and storage

Keep locating the shipping carton boxes to suitable side up. Otherwise, unexpected stress might affect to the boxes. For example, bend the terminal pins, deform the inner resin case, and so on.

When you throw or drop the product, it gives the product damage.

If the product is wet with water, that it may be broken or malfunctions, please subjected to sufficient measures to rain or condensation.

Temperature and humidity of an environment during transportation are described in the specification sheet. There conditions shall be kept under the specification.

(2) Assembly environment

Since this power module device is very weak against electro static discharge, the ESD countermeasure in the assembly environment shall be suitable within the specification described in specification sheet. Especially, when the conducting pad is removed from control pins, the product is most likely to get electrical damage.

(3) Operating environment

If the product had been used in the environment with acid, organic matter, and corrosive gas (hydrogen sulfide, sulfurous acid gas), the product's performance and appearance can not be ensured easily.

Chapter 4 Typical application circuits

1. Typical application circuits	4-2
2. Important remarks	4-6
3. Optocoupler peripheral circuits	4-9
4. Connector	4-10

This chapter describes the typical application circuits of the X series IPM.

1. Typical application circuits

Figure 4-1 shows the typical application circuits of P629 and P639 (6in1, only lower arm has alarm signal output function.)

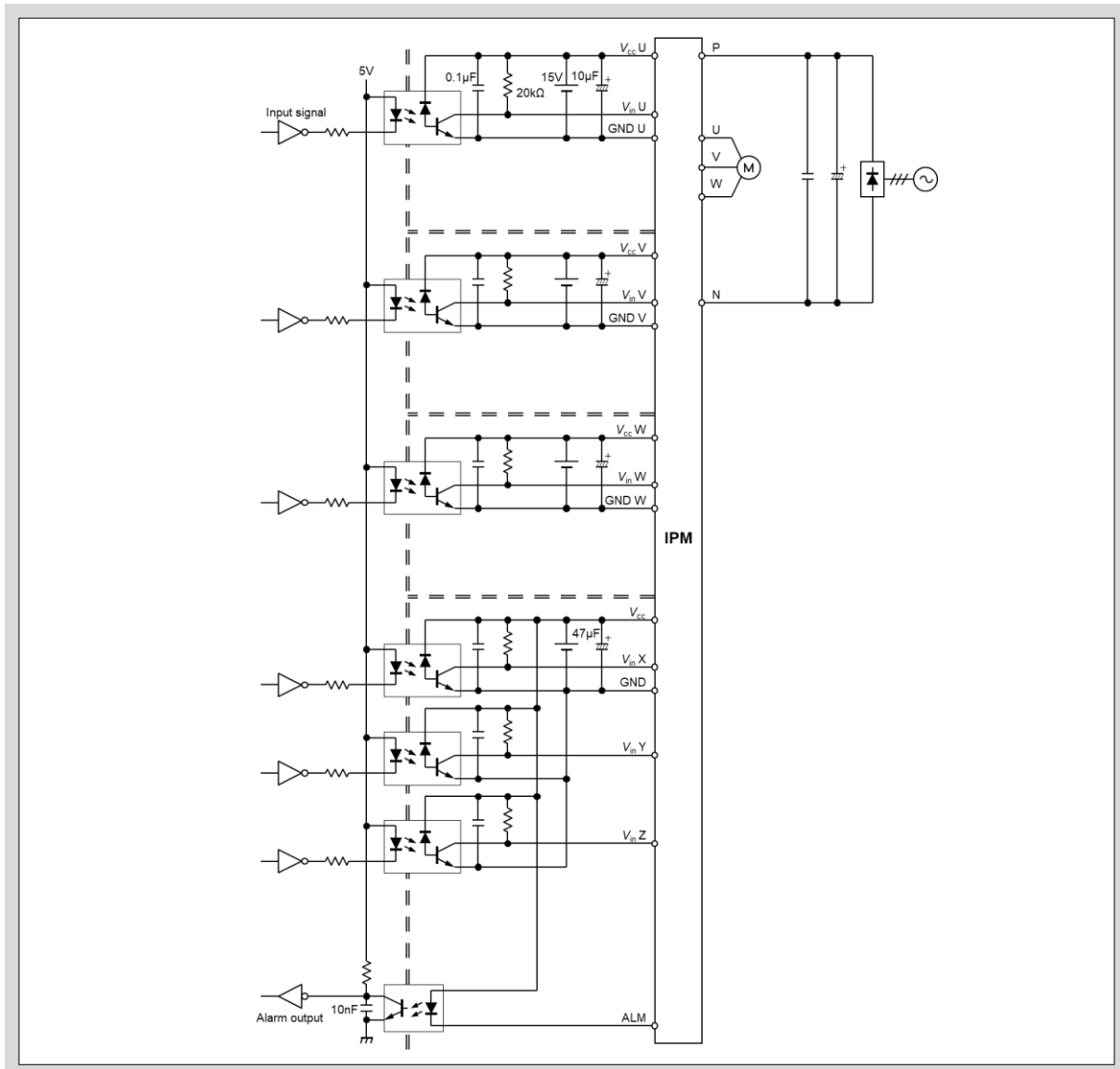

Fig.4-1 Typical application circuits of P629 and P639

Figure 4-3 shows the typical application circuits of P626, P630, P631, P636 and P638 (6in1, with temperature warning function type).

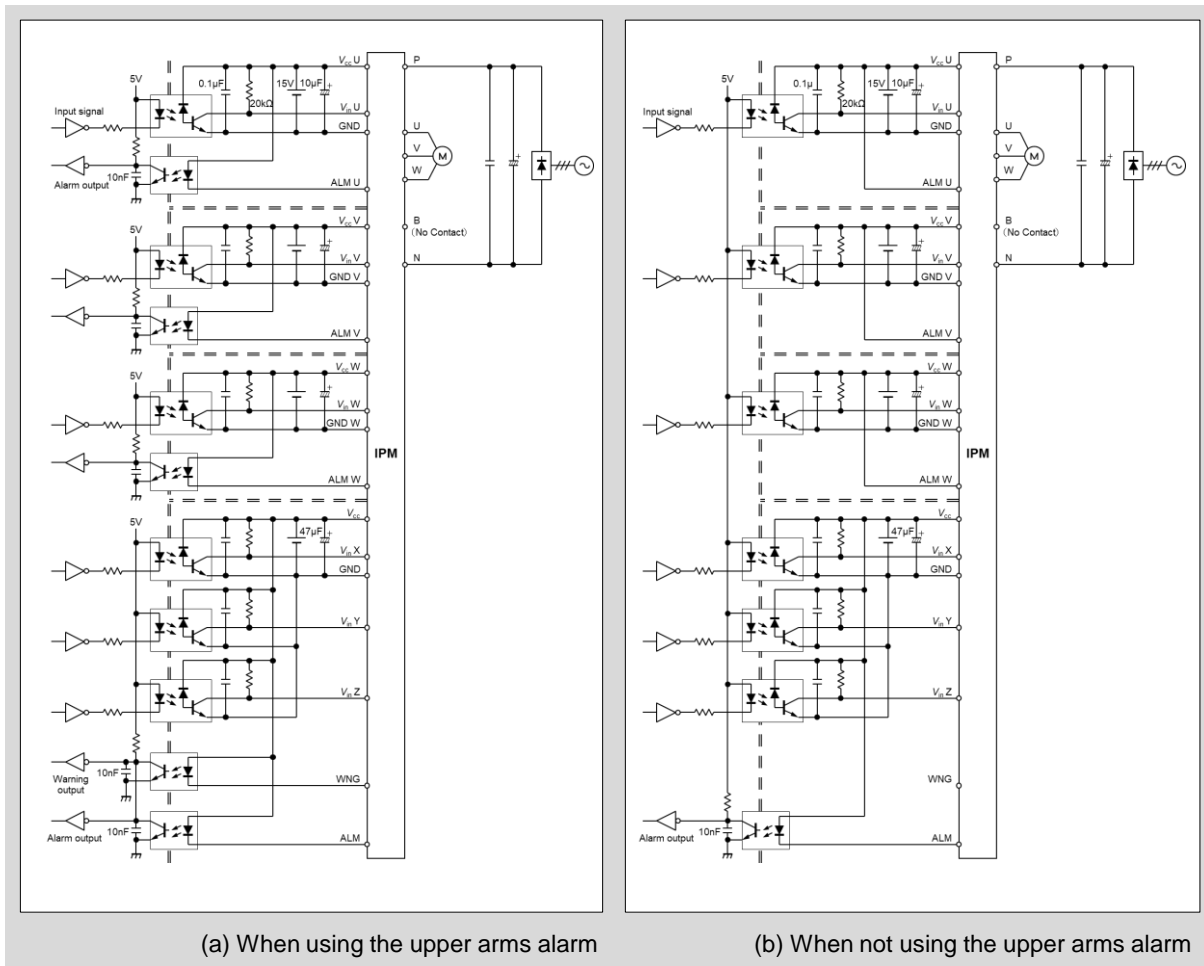

Fig.4-3 Typical application circuits of P626, P630, P631, P636 and P638 (6in1, with temperature warning function)

- If the temperature warning function is not used, open the WNG terminal.
If the WNG terminal is connected to the V_{CC} terminal, the consumption current I_{CC} increases when the temperature of the IPM reaches the temperature warning level.

Figure 4-4 shows the typical application circuits of P630, P631, P636 and P644 (7in1, with built-in brake).

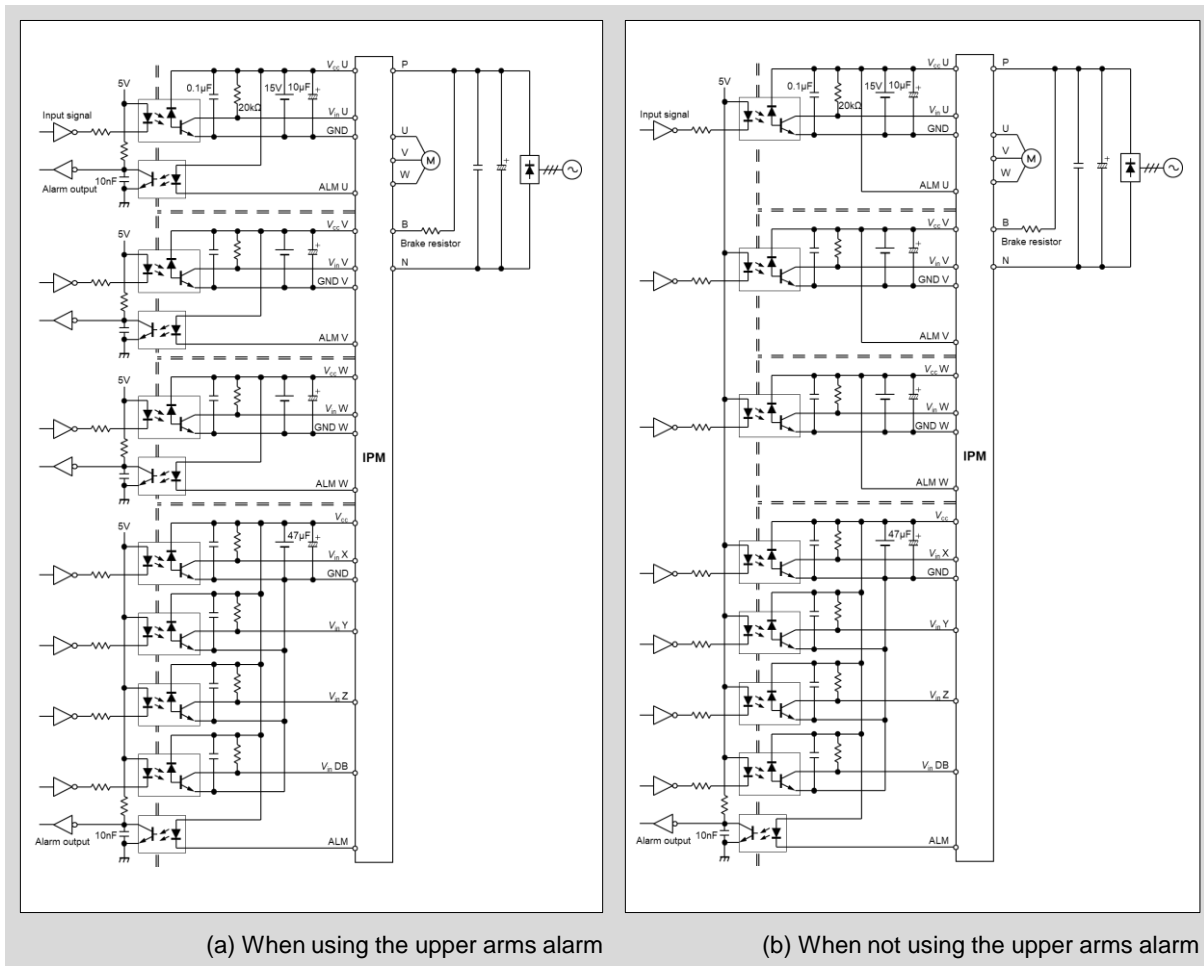

Fig.4-4 Typical application circuits of P630, P631, P636 and P644 (7in1)

2. Important remarks

2.1 Control power supply units

A total of four isolated power supply units; three for the upper arm and one for the lower arm are required as shown in the application circuit examples. Mount an aluminum electrolytic capacitor (upper arm: approx.50V/10 μ F, lower arm: approx.50V/47 μ F) as close as possible to the control power terminal V_{CC} of the IPM. This capacitor is not for smoothing the control power supply, but for compensating the wiring impedance up to IPM. It is predicted that the use of only a single power supply such as a bootstrap causes voltage fluctuations. Thus, careful consideration and verification are required.

When using a commercially available power supply unit, do not use the output GND terminal of the power supply unit. If the GND of the output side is connected to the + or - terminals, it may cause a malfunction because each power supply unit is connected to the power ground of input side. Furthermore, reduce the stray capacitance (floating capacitance) between the power supply unit and the GND as much as possible.

In addition, use a power supply unit with sufficient I_{CC} supply capacity and reduce output voltage fluctuations.

2.2 Structural insulation between four power supply units (input portion connector and PCB)

The four power supply units and the main power source have to be insulated from each other. Be sure to secure a sufficient insulation distance because high dv/dt is applied to this insulation part during IGBT switching. (2 mm or longer is recommended)

2.3 GND connection

Do not connect the control terminal GND U and the main terminal U, control terminal GND V and main terminal V, control terminal GND W and main terminal W, control terminal GND and main terminal N (N1 and N2 in the case of P631) to external circuits. In that case, it may cause a malfunction.

2.4 External capacitors for control power supply

Capacitors of 10 μ F (47 μ F) and 0.1 μ F connected to each power supply unit shown in typical application circuits are not used for smoothing the output voltage of the power supply units, but for compensating the wiring impedance from the power supply unit up to the IPM. Additional smoothing capacitors are required. Furthermore, these external capacitors should be connected as close as possible to the IPM control terminals or optocoupler terminals because transient fluctuation occurs in the wiring impedance between these capacitors and the control circuits.

An electrolytic capacitor which has low impedance and good frequency characteristics is recommended. In addition, it is recommended to connect a film capacitor with good frequency characteristics in parallel.

2.5 Alarm circuit

The X-IPM has a built-in 1.3k Ω alarm output resistor, so that an optocoupler can be connected to the terminal directly without an external resistor. The wiring distance between the optocoupler and the IPM should be as short as possible. Also, the pattern layout should be designed to minimize the floating capacitance between the primary side and the secondary side of the optocoupler.

Since a dv/dt may cause the secondary side potential of the optocoupler to fluctuate, it is recommended to connect a capacitor of about 10nF to the output terminal on the secondary side of the optocoupler to stabilize the potential as shown in Figure 4-4.

Furthermore, regarding IPMs with an upper arm alarm output function, connect the alarm output terminal to V_{CC} as shown in Figure 4-4 (b) in order to stabilize the potential if the upper arm alarm output function is not used.

2.6 Warning circuit (specific models only)

Since the X-IPM has a built-in 1.3k Ω warning output resistor, the optocoupler can be directly connected without an external resistor. When connecting the optocoupler, make not only the wiring between the optocoupler and the IPM as short as possible, but also the pattern layout that reduces the stray capacitance between the primary and secondary sides of the optocoupler.

Since a dv/dt may cause the secondary side potential of the optocoupler to fluctuate, it is recommended to connect a capacitor of about 10nF to the output terminal on the secondary side of the optocoupler in order to stabilize the potential.

Also, when the temperature warning function is operating, the consumption current by V_{CC}/R_{WNG} increases, so please consider the design of the power supply. If the temperature warning function is not used, it is recommended to keep the WNG terminal open. If the warning terminal is pulled up to V_{CC} , the consumption current increases when the temperature warning function operates. Thus, design the power supply properly. In addition, do not pull down the warning terminal to GND.

2.7 Pull-up of signal input terminal

Connect the control signal input terminals to V_{CC} through a 20k Ω pull-up resistor. Furthermore, unused input terminals also have to be pulled up to V_{CC} through the 20k Ω resistor. If these terminals are not pulled up to V_{CC} , UV protection is activated and IPM cannot operate.

2.8 Connection when there is an unused phase

If there are cases when a 6in1 (without brake part) is used in only single phase or a 7in1 (with brake part) is used without brake part, supply control voltage to these unused phase and connect the input/alarm terminals to V_{CC} to stabilize the potential of these terminals. The warning signal output terminal is excluded. (refer to 4.2.6)

2.9 Handling of unconnected terminals (no contact terminals)

Unconnected terminals (no contact terminals) are not connected inside of the IPM. These terminals are insulated from other terminals. There is no need of special treatment such as potential stabilization.

Also, guide pins are not connected inside of the IPM.

2.10 Snubber

Directly connect a snubber circuit to the P/N terminals as close as possible. For P631 package which has two P/N terminals, it is effective to connect snubber circuits to both P1-N1 and P2-N2 terminals to reduce surge voltage. Do not connect snubber circuits across the two terminals such as P1-N2 and P2-N1 as it may cause a malfunction.

2.11 Grounding capacitor

Connect grounding capacitors between each AC input line and its ground to prevent noise from flowing in the system.

2.12 Input circuit of IPM

There are constant current circuits in the input circuit of IPMs as shown in Figure 4-5(a). The constant current of $I_{in} = 0.15 \text{ mA}$ or $I_{in} = 0.65 \text{ mA}$ flows at that timing shown in Figure 4-5(b). The current of the secondary side of optocoupler is the sum of the constant current I_{in} and the current through a pull-up resistor I_R . Therefore, it is necessary to determine the current of the primary side of optocoupler I_F so that sufficient current can flow in the secondary side of optocoupler. If I_F is insufficient, the secondary side may a malfunction.

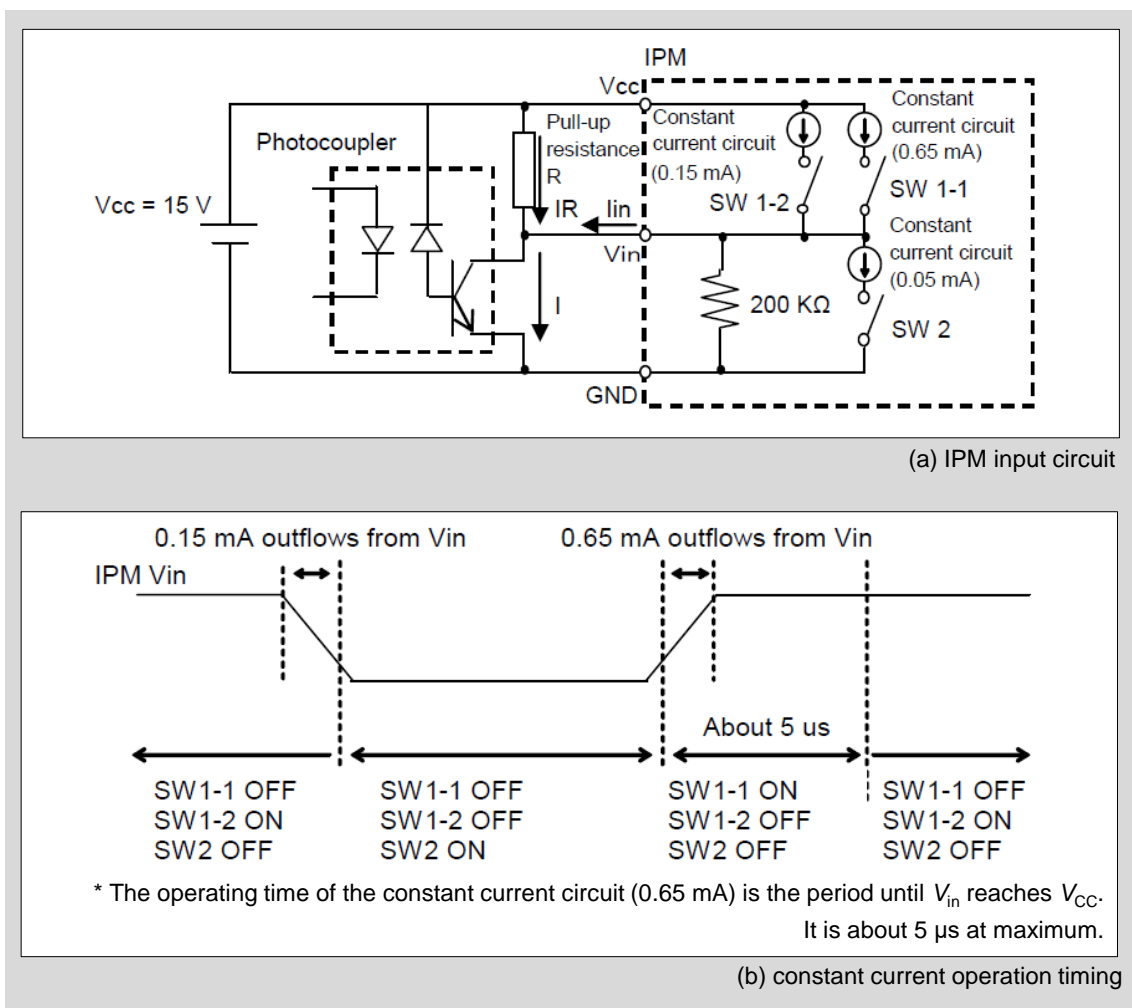

Fig.4-5 IPM input circuit and constant current operation timing

3. Optocoupler peripheral circuits

3.1 Optocoupler for control input

3.1.1 Optocoupler rating

Use an optocoupler that satisfies the following characteristics.

- $CMH = CML > 15kV/\mu s$ or $10kV/\mu s$
- $tpHL = tpLH < 0.8\mu s$
- $tpLH - tpHL = -0.4 \sim 0.9\mu s$
- $CTR > 15\%$

Example:

HCPL-4504 by Broadcom

TLP759 (IGM) by Toshiba

TLP2958 by Toshiba

PS9513 by Renesas Electronics

Pay attention to safety standards such as UL and VDE.

The reliability and characteristics of these optocouplers are not guaranteed by Fuji Electric.

3.1.2 Primary side current limiting resistor

The current limiting resistor on the primary side should be selected so that sufficient current can flow on the secondary side. Also, deterioration of CTR of the optocoupler over time should be considered in the design of the current limiting resistor.

3.1.3 Wiring between optocoupler and IPM

The wiring distance between the optocoupler and the IPM should be short as much as possible to reduce the wiring impedance. Make sure that the primary and secondary lines of the optocoupler are not close together to reduce the floating capacitance. A high dv/dt is applied between the primary side and the secondary side.

3.2 Optocoupler for alarm signal output and temperature warning output

3.2.1 Optocoupler rating

A general-purpose optocoupler can be used but an optocoupler with the following characteristics is recommended.

- $100\% < \text{CTR} < 300\%$
- Single channel type

Example:

TLP781-1-GR rank or TLP785-1-GR rank by Toshiba

Pay attention to safety standards such as UL and VDE.

The reliability and characteristics of these optocouplers are not guaranteed by Fuji Electric.

3.2.2 Input current limiting resistance

The current limiting resistor for the primary side of optocoupler is built in the X-IPMs.

The resistance is $R_{\text{ALM}}=1.3\text{k}\Omega$. When the optocoupler is directly connected to $V_{\text{CC}}=15\text{V}$, IF flows about 10mA. Therefore, external current limiting resistors are unnecessary.

If a large current $I_{\text{out}} > 10\text{mA}$ is required for the optocoupler output side, it is necessary to increase the optocoupler's CTR value in order to supply the required current.

3.2.3 Wiring between optocoupler and IPM

Note that a high dv/dt will be applied to the optocoupler for alarm signal output and temperature warning output, please take the same precautions as in section 3.1.3.

4. Connector

For the connector's electrode surface material (plating, etc.), select the same material as the IPM control terminal plating material.

Connectors that conform to the shape of control terminals of X-IPM are commercially available.

For P630: MA49-19S-2.54DSA and MA49-19S-2.54DSA (01) by Hirose Electric

For P631: MDF7-25S-2.54DSA by Hirose Electric

Furthermore, please contact the connector manufacturer for the details of reliability and use of these connectors.

Please note that the reliability and the characteristics of these connectors are not guaranteed by Fuji Electric.