

Small IPM (Intelligent Power Module)

P642 Series

6MBP\*\*XT\*065-50

## Application Manual

## CONTENTS

### Chapter 1 Product Outline

1. Introduction	1-2
2. Product Lineup and Target Application	1-4
3. Definition of Type Name and Marking Specification	1-5
4. Package Outline Dimensions	1-6
5. Absolute Maximum Ratings	1-7

### Chapter 2 Description of Terminal Symbols and Terminology

1. Description of Terminal Symbols	2-2
2. Description of Terminology	2-3

### Chapter 3 Details of Control & Protection Functions

1. Control Power Supply, VCCH(U,V,W), VCCL, COM	3-2
2. High-side Bias Voltage, VB(U,V,W), VS(U,V,W)	3-6
3. Function of Built-in BSDs (Bootstrap Diodes)	3-9
4. Signal Input, IN(HU,HV,HW), IN(LU,LV,LW)	3-14
5. Overcurrent Protection Function, IS	3-17
6. Fault Status Output Function, VFO, CFO	3-19
7. Temperature Output Function, TEMP	3-21
8. Overheating Protection Function	3-23

### Chapter 4 Details of Inverter Block

1. Connection of Bus Voltage Input Terminal and Low-side IGBTs Emitter	4-2
2. About Short Circuit Protection	4-4
3. Setting of External Shunt Resistor for Overcurrent Protection	4-6

### Chapter 5 Recommended Wiring and Layout

1. Examples of Application Circuit	5-2
2. Recommendations and Precautions in PCB Design	5-6

## CONTENTS

### Chapter 6 Mounting Guidelines and Thermal Design

1. Soldering to PCB	6-2
2. Mounting to Heat Sink	6-3
3. Spacer Position	6-4
4. Cooler (Heat Sink) Selection	6-5

### Chapter 7 Notes

1. Precautions for Use	7-2
2. Precautions for Handling and Storage	7-4
3. Notice	7-5

## Chapter 1 Product Outline

1. Introduction	1-2
2. Product Lineup and Target Application	1-4
3. Definition of Type and Marking Specification	1-5
4. Package Outline Dimension	1-6
5. Absolute Maximum Ratings	1-7

## 1. Introduction

This manual describes the following contents for Fuji IGBT Intelligent-Power-Module “Small-IPM P642 series”

- Product summary
- Explanation of terminal symbols and terms
- Detailed explanation and design guideline of control terminals and power terminals
- Recommended wiring, layout and mounting guidelines

### **1.1 Product features**

- 7th generation IGBT technology reduces power loss and realizes energy saving of equipment.
- Expansion of operating current by guaranteed  $T_{vjop}=150^{\circ}\text{C}$  and time limited  $T_{vj}=175^{\circ}\text{C}$  operation.
- Expansion of overload operating area by higher accuracy of short circuit protection detection.
- Lineup of 650V / 50A, 75A.

### **1.2 Built-in drive circuit**

- The control IC of upper side arms have built-in high voltage level shift circuit (HVIC).
- The IPM can be driven directly by a microprocessor. The high-side IGBT can be driven directly. The voltage level of input signal is 3.3V or 5.0V.
- No reverse bias power supply is required due to short wiring length between the built-in drive circuit and IGBT and the impedance of the drive circuit is low.
- The IPM doesn't need insulated power supplies for high-side drive because the IPM has built-in bootstrap diodes (BSD).

### **1.3 Built-in protection circuit**

- The following built-in protection circuits are incorporated in the IPM device:
  - (OC): Overcurrent protection
  - (UV): Under voltage protection for power supplies of control IC
  - (LT) or (OH): Temperature sensor output function or Overheating protection
  - (FO): Fault status output
- The OC protection circuit protects the IGBT from overcurrent due to load short-circuit and arm short-circuit. This protection circuit adopts both sense current method and external shunt resistor method, thus arm short-circuit protection is possible.
- The UV protection circuit is triggered when there is voltage drop at the control power supply and the high-side drive power supply. It is integrated into all IGBT drive circuits.
- The OH protection circuit protects the IPM from overheating. It is built into the low side control IC (LVIC).
- The temperature sensor output function outputs temperature as analog voltage. It is built into LVIC.
- The FO function outputs an alarm signal when the IPM detects abnormal conditions. By outputting an alarm signal to the microprocessor unit (MPU), it is possible to shut down and prevent destruction of the system.

### 1.4 Compact package

- This IPM adopts aluminum insulating metal substrate (IMS) and has excellent heat dissipation.
- The pitch between control terminals is 2.54mm.
- The pitch between power terminals is 10mm.
- Total power loss is reduced by improving the trade-off between Collector-Emitter saturation voltage  $V_{CE(sat)}$  and switching loss.

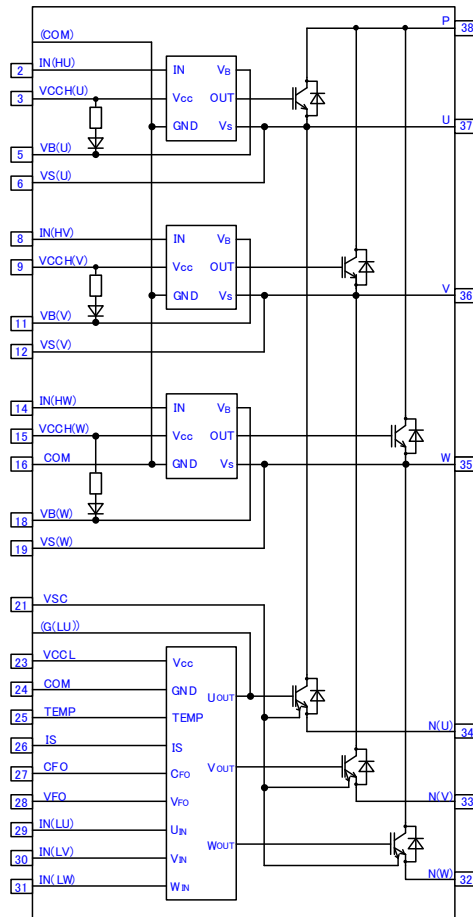

Fig. 1-1 Internal circuit diagram



Fig. 1-2 Package external view

## 2. Product Lineup and Target Application

Table 1-1 Lineup

Type Name	IGBT Rating		Isolation Voltage [Vrms]	Variation
	Voltage [V]	Current [A]		
6MBP50XTA065-50	650	50	2500Vrms Sinusoidal 60Hz, 1min. (Between shorted all terminals and IMS)	LT*1
6MBP50XTC065-50				LT*1 OH*1
6MBP75XTA065-50		75		LT*1
6MBP75XTC065-50				LT*1 OH*1

\*1 (LT): Temperature sensor output function  
(OH): Overheating protection

### 3. Definition of Type and Marking Specification

• Type Name

**6 MBP 50 X T C 065 -50**

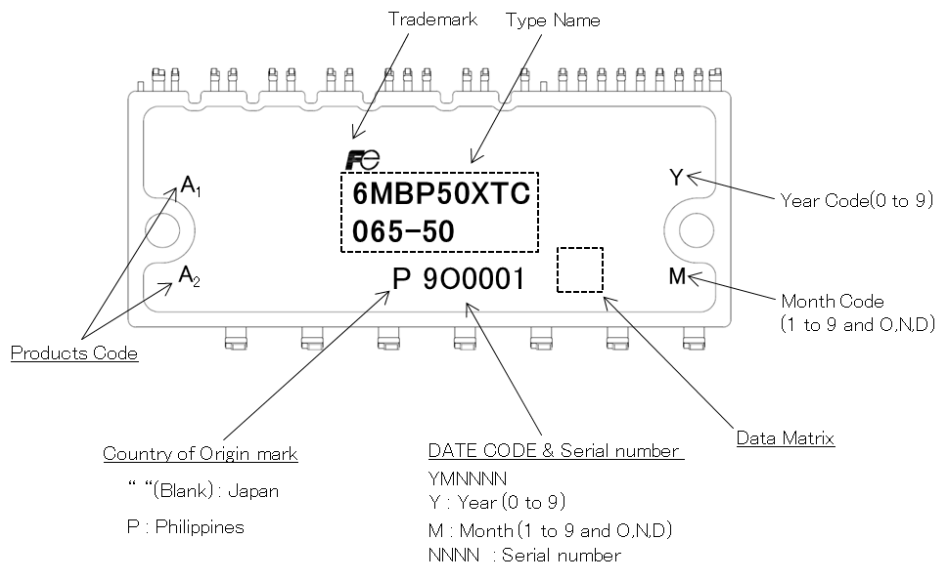
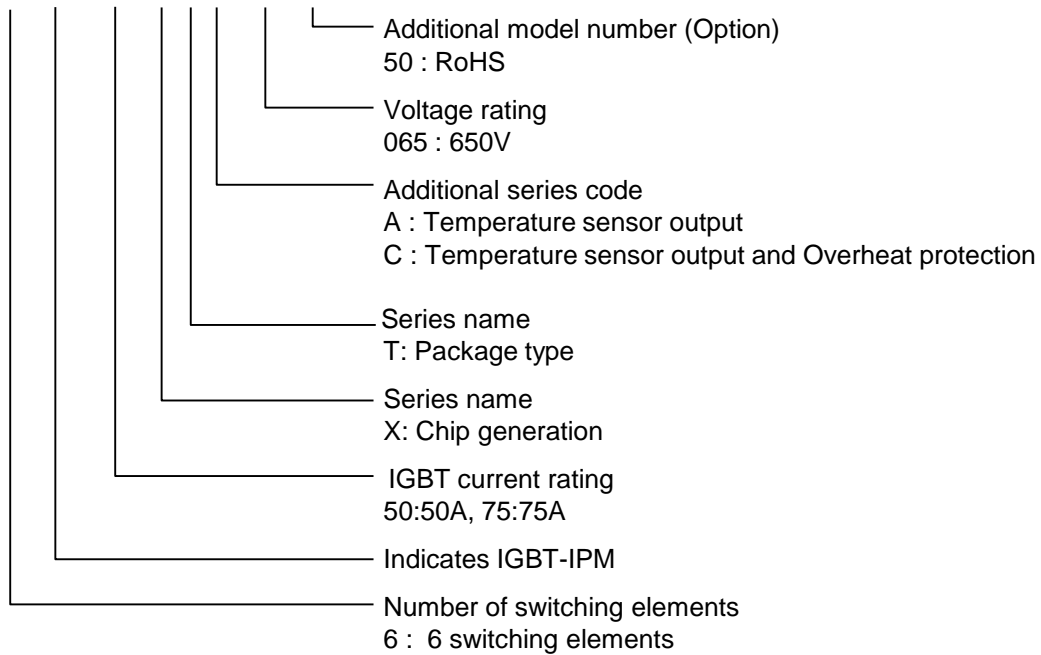

TYPE NAME	PRODUCT CODE	
	A <sub>1</sub>	A <sub>2</sub>
6MBP50XTA065-50	A	A
6MBP50XTC065-50	A	C
6MBP75XTA065-50	B	A
6MBP75XTC065-50	B	C

Fig. 1-3 Marking specification



## 4. Package Outline Dimension

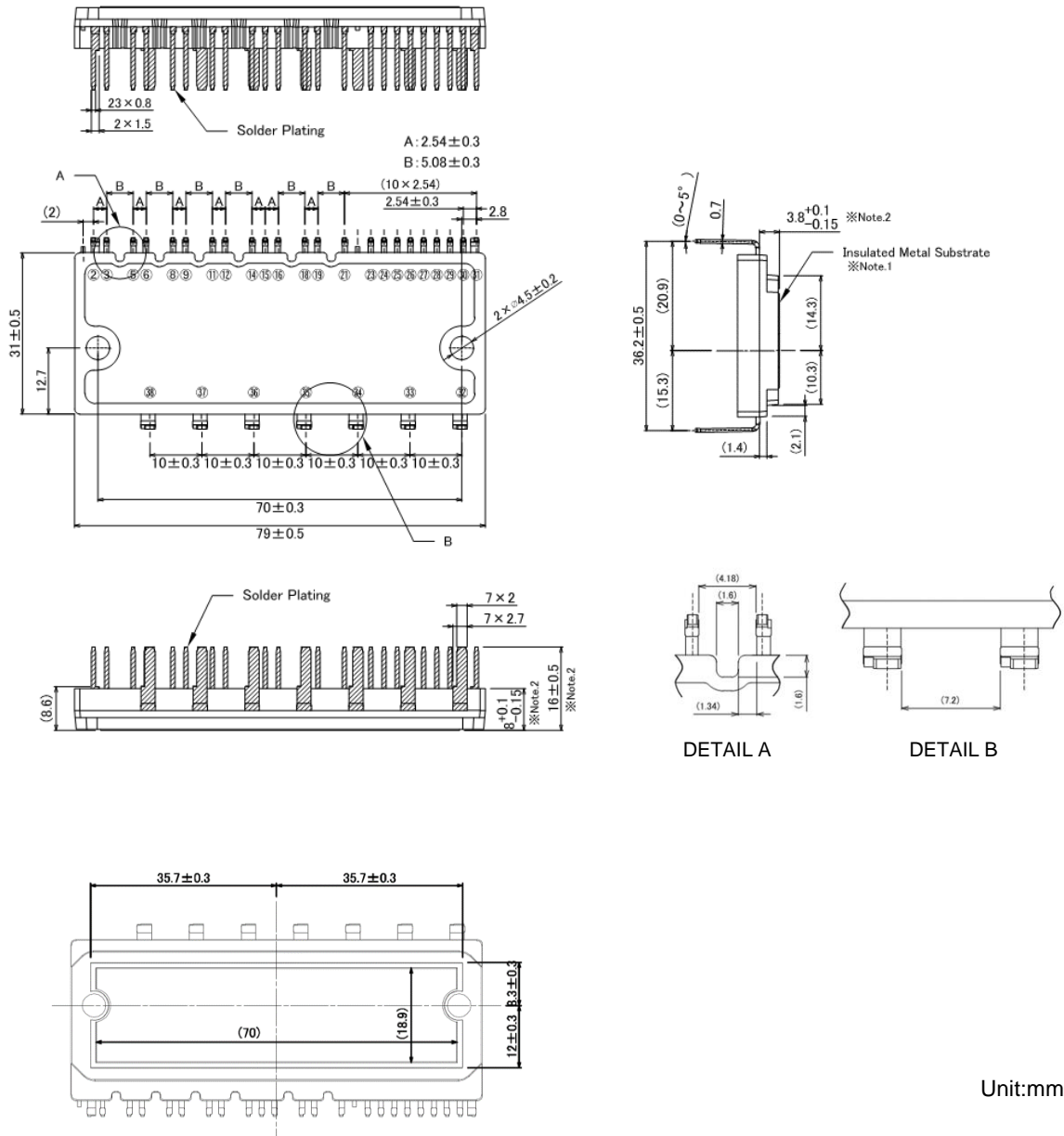

Unit:mm

**Note.1**

The IMS (Insulated Metal Substrate) is deliberately protruded to improve the thermal conductivity between IMS and heat-sink.

**Note.2**

Thickness from the package surface to the back side including the IMS.

Fig. 1-4 Case outline drawing

## 5. Absolute Maximum Ratings

An example of the absolute maximum ratings of 6MBP50XTA065-50 is shown in Table 1-2.

Table 1-2 Inverter Block Absolute Maximum Ratings at  $T_{vj}=25^{\circ}\text{C}$ ,  $T_c=25^{\circ}\text{C}$ ,  $V_{CC}^{*1}=15\text{V}$ ,  $V_{B(*)}=15\text{V}$  (unless otherwise specified)

Item	Symbol	Rating	Unit	Description
DC Bus Voltage	$V_{DC(\text{terminal})}$	450	V	DC voltage that can be applied between P-N(U),N(V),N(W) terminals. Please refer to Fig. 1-5 for details.
Bus Voltage (Surge)	$V_{DC(\text{Surge,terminal})}$	500	V	Peak value of the surge voltage that can be applied between P-N(U),N(V),N(W) terminals during switching operation. Please refer to Fig. 1-5 for details.
Collector-Emitter Voltage	$V_{CE(\text{chip})}$	650	V	Maximum collector-emitter voltage of IGBT and repeated peak reverse voltage of FWD. Please refer to Fig. 1-5 for details.
Collector Current	$I_C$	50	A	Maximum collector current of IGBT at $T_c=25^{\circ}\text{C}$ , $T_{vj}=150^{\circ}\text{C}^{*2}$
Peak Collector Current	$I_{CP}$	100	A	Maximum pulse collector current of IGBT at $T_c=25^{\circ}\text{C}$ , $T_{vj}=150^{\circ}\text{C}^{*2}$
Forward Current	$I_F$	50	A	Maximum forward current of FWD at $T_c=25^{\circ}\text{C}$ , $T_{vj}=150^{\circ}\text{C}^{*2}$
Peak Forward Current	$I_{FP}$	100	A	Maximum pulse forward current of FWD at $T_c=25^{\circ}\text{C}$ , $T_{vj}=150^{\circ}\text{C}^{*2}$
Collector Power Dissipation	$P_{D\_IGBT}$	132	W	Maximum power dissipation per IGBT at $T_c=25^{\circ}\text{C}$ , $T_{vj}=150^{\circ}\text{C}^{*2}$
FWD Power Dissipation	$P_{D\_FWD}$	89	W	Maximum power dissipation per FWD at $T_c=25^{\circ}\text{C}$ , $T_{vj}=150^{\circ}\text{C}^{*2}$
Self Protection DC Bus Voltage (arm short-circuit)	$V_{DC(\text{sc})}$	400	V	Maximum DC voltage at which IGBT can be safely shut off by the IPM's protection function during short-circuit or overcurrent. Please refer to Fig. 1-5 for details.
Maximum Virtual Junction Temperature of Inverter Block	$T_{vj}$	175	$^{\circ}\text{C}$	Maximum virtual junction temperature of IGBT and FWD <sup>*3</sup>
Operating Virtual Junction Temperature of Inverter Block	$T_{vjop}$	-40 ~ +150	$^{\circ}\text{C}$	Virtual Junction Temperature of IGBT and FWD during continuous operation <sup>*3</sup>

Table 1-2 Control Circuit Block Absolute Maximum Ratings at  $T_{vj}=25^{\circ}\text{C}$ ,  $T_c=25^{\circ}\text{C}$ ,  $V_{CC}^{*1}=15\text{V}$ ,  $V_{B(r)}=15\text{V}$   
 (continued)

Item	Symbol	Rating	Unit	Description
High-side Supply Voltage	$V_{CCH(U)}$ $V_{CCH(V)}$ $V_{CCH(W)}$	-0.5 ~ 20	V	Voltage that can be applied between VCCH(U)-COM, VCCH(V)-COM, VCCH(W)-COM terminals.
Low-side Supply Voltage	$V_{CCL}$	-0.5 ~ 20	V	Voltage that can be applied between VCCL-COM terminals.
High-side Bias Absolute Voltage	$V_{VB(U)-COM}$ $V_{VB(V)-COM}$ $V_{VB(W)-COM}$	-0.5 ~ 670	V	Voltage that can be applied between VB(U)-COM, VB(V)-COM, VB(W)-COM terminals.
High-side Bias Voltage for IGBT Gate Driving	$V_{B(U)}$ $V_{B(V)}$ $V_{B(W)}$	-0.5 ~ 20	V	Voltage that can be applied between VB(U)-VS(U), VB(V)-VS(V), VB(W)-VS(W) terminals.
High-side Bias Offset Voltage	$V_U$ $V_V$ $V_W$	-5 ~ 650	V	Voltage that can be applied between U-COM, V-COM, W-COM terminals. <sup>*4</sup>
Input Signal Voltage	$V_{IN}$	-0.5 ~ $V_{CCH}+0.5$ -0.5 ~ $V_{CCL}+0.5$	V	Voltage that can be applied between IN(HU)-COM, IN(HV)-COM, IN(HW)-COM, IN(LU)-COM, IN(LV)-COM, IN(LW)-COM terminals.
Input Signal Current	$I_{IN}$	3	mA	Maximum current between IN(HU)-COM, IN(HV)-COM, IN(HW)-COM, IN(LU)-COM, IN(LV)-COM, IN(LW)-COM terminals.
Fault Signal Voltage	$V_{FO}$	-0.5 ~ $V_{CCL}+0.5$	V	Voltage that can be applied between VFO-COM terminals.
Fault Signal Current	$I_{FO}$	1	mA	Maximum sink current between VFO-COM terminals.
CFO Signal Voltage	$V_{CFO}$	-0.5 ~ 5.0	V	Voltage that can be applied between CFO-COM terminals. <sup>*5</sup>
CFO Signal Current	$I_{CFO}$	-0.05 / 3	mA	Maximum source / sink current between CFO-COM terminals. <sup>*5</sup>
Over Current Sensing Input Voltage	$V_{IS}$	-0.5 ~ $V_{CCL}+0.5$	V	Voltage that can be applied between IS-COM terminals.
TEMP Signal Voltage	$V_{TEMP}$	-0.5 ~ 5.0	V	Voltage that can be applied between TEMP-COM terminals.
TEMP Signal Current	$I_{TEMP}$	-0.05 / 3	mA	Maximum source / sink current between TEMP-COM terminals.
VSC Signal Voltage	$V_{VSC}$	-0.5 ~ $V_{CCL}+0.5$	V	Voltage that can be applied between VSC-COM terminals. <sup>*6</sup>
VSC Signal Current	$I_{VSC}$	-20	mA	Maximum source current between VSC-COM terminals. <sup>*6</sup>

Table 1-2 Control Circuit Block Absolute Maximum Ratings at  $T_{vj}=25^{\circ}\text{C}$ ,  $T_c=25^{\circ}\text{C}$ ,  $V_{CC}^{*1}=15\text{V}$ ,  $V_{B(*)}=15\text{V}$  (continued)

Item	Symbol	Rating	Unit	Description
Virtual Junction Temperature of Control Circuit Block	$T_{vj}$	150	$^{\circ}\text{C}$	Average virtual junction temperature of the control circuit.
Operating Case Temperature	$T_c$	-40 ~ +125	$^{\circ}\text{C}$	Operating case temperature (temperature of IMS directly under the IGBT or FWD chip).
Storage Temperature	$T_{stg}$	-40 ~ +125	$^{\circ}\text{C}$	Ambient temperature range for storage and transportation (no load condition).
Isolation Voltage	$V_{isol}$	AC 2500	Vrms	Maximum voltage between IMS and all shorted terminals (Sine wave 60Hz, 1min)

\*1  $V_{CC}$  is applied between VCCH(U,V,W)-COM and VCCL-COM terminals.

\*2 Pulse width and duty are limited by  $T_{vj}$ .

\*3 The maximum virtual junction temperature during continuous operation is  $T_{vj}=150^{\circ}\text{C}$ . Continuous operation at over  $T_{vj}=150^{\circ}\text{C}$  may result in degradation of product lifetime such as power cycling capability with respect to the designed lifetime.

\*4 Apply 13.0V or more between VB(U)-U, VB(V)-V, VB(W)-W terminals.

The IPM might malfunction if the high-side bias offset voltage is less than -5V.

\*5 CFO is output terminal. Do not apply voltage or current.

Connect only the specified capacitor between CFO-COM terminals.

\*6 VSC is output terminal. Do not apply voltage or current.

Connect only the specified resistor between VSC-COM terminals.

### Absolute Maximum Rating of Collector-Emitter Voltage

The absolute maximum rating of collector-emitter voltage of the IGBT is specified below.

During operation, the voltage between P-N(\*)<sup>\*1</sup> is usually applied to high-side or low side of one phase.

Therefore, the voltage between P-N(\*) must not exceed the absolute maximum rating of IGBT.

The collector-emitter voltage absolute maximum rating is described below.

\*1 N(\*) : N(U), N(V), N(W)

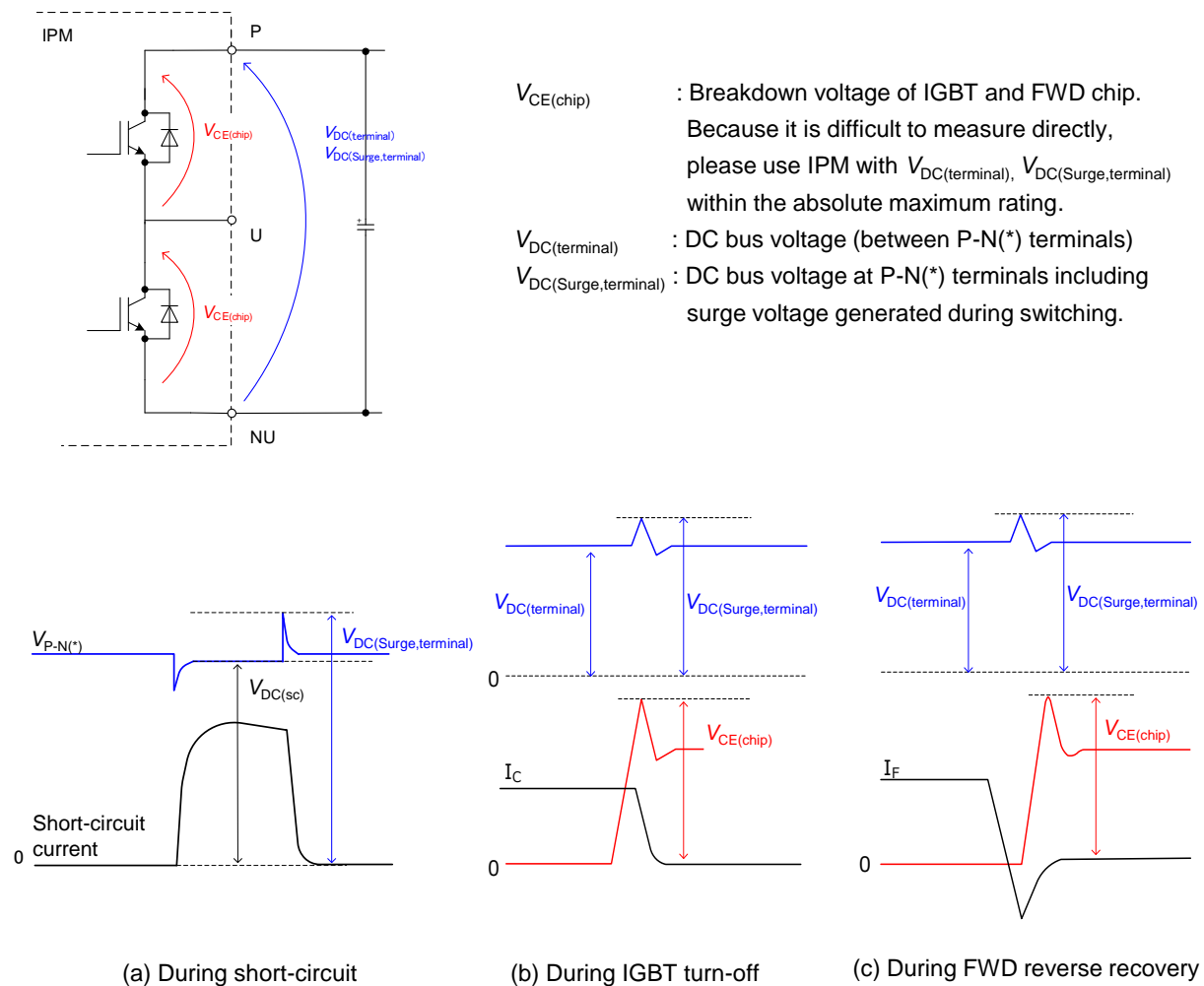

Fig.1-5 Collector-emitter voltage

Fig.1-5 shows the waveforms during short-circuit, IGBT turn-off and FWD reverse recovery.

Since  $V_{DC(Surge,terminal)}$  is different in each situation, it is necessary to set  $V_{DC(terminal)}$  considering these situations.

$V_{CE(chip)}$  is the collector-emitter voltage absolute maximum rating of the IGBT chip.  $V_{DC(Surge,terminal)}$  is specified considering the margin of surge voltage generated by the wiring inductance inside the IPM.

$V_{DC(terminal)}$  is specified considering the margin of surge voltage generated by the wiring inductance between P-N(\*) terminals and electrolytic capacitor.

## Chapter 2 Description of Terminal Symbols and Terminology

1. Description of Terminal Symbols	2-2
2. Description of Terminology	2-3

## 1. Description of Terminal Symbols

Table 2-1 and Table 2-2 describe the terminal symbols and terminology, respectively.

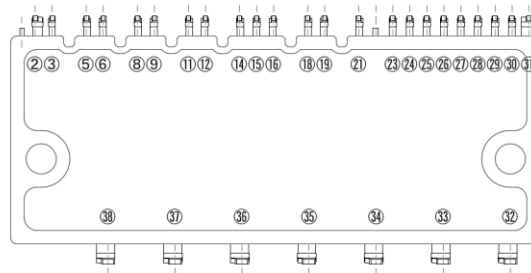

Fig. 2-1 Terminals number

Table 2-1 Description of terminal symbols

Terminal No.	Terminal Name	Terminal Description	Terminal No.	Terminal Name	Terminal Description
2	IN(HU)	Signal Input for High-side U-phase	24	COM	Low-side Control Power Supply GND
3	VCCH(U)	High-side Control Power Supply for U-phase	25	TEMP	Temperature Sensor Output
5	VB(U)	High-side Bias Voltage for U-phase	26	IS	Overcurrent Sensing Voltage Input
6	VS(U)	High-side Bias Voltage for U-phase GND	27	CFO	Fault Output Pulse Width Setting
8	IN(HV)	Signal Input for High-side V-phase	28	VFO	Fault Output
9	VCCH(V)	High-side Control Power Supply for V-phase	29	IN(LU)	Signal Input for Low-side U-phase
11	VB(V)	High-side Bias Voltage for V-phase	30	IN(LV)	Signal Input for Low-side V-phase
12	VS(V)	High-side Bias Voltage for V-phase GND	31	IN(LW)	Signal Input for Low-side W-phase
14	IN(HW)	Signal Input for High-side W-phase	32	N(W)	Negative Bus Voltage Input for W-phase
15	VCCH(W)	High-side Control Power Supply for W-phase	33	N(V)	Negative Bus Voltage Input for V-phase
16	COM	High-side Control Power Supply GND	34	N(U)	Negative Bus Voltage Input for U-phase
18	VB(W)	High-side Bias Voltage for W-phase	35	W	W-phase Output
19	VS(W)	High-side Bias Voltage for W-phase GND	36	V	V-phase Output
21	VSC	Low-side Sense Current Detection	37	U	U-phase Output
23	VCCL	Low-side Control Power Supply	38	P	Positive Bus Voltage Input

## 2. Description of Terminology

Table 2-2 Description of terminology

(1) Inverter Block

Item	Symbol	Description
Zero Gate Voltage Collector Current	$I_{CE}$	Leakage current when a specified voltage is applied between the collector and emitter of an IGBT with all input signals L (= 0V).
Collector-Emitter Saturation Voltage	$V_{CE(sat)}$ (terminal)	Collector-emitter voltage at a specified collector current when only the input signal of the element under measurement is H (= 5V) and the inputs of all other elements are L (= 0V).
Forward Voltage	$V_F$	Forward voltage at a specified forward current with all input signals L (= 0V).
Turn-on Time	$t_{on}$	The time from when the input signal voltage level exceeds the threshold value until the collector current rises to 90% of rating. See Fig. 2-2 for details.
Turn-on Delay Time	$t_{d(on)}$	The time from when the input signal voltage level exceeds the threshold value until the collector current rises to 10% of rating. See Fig. 2-2 for details.
Turn-on Rise Time	$t_r$	The time for the collector current to rise from 10% of rating to 90% of rating when the IGBT is turned on. See Fig. 2-2 for details.
$V_{CE}-I_C$ Cross Time of Turn-on	$t_{c(on)}$	The time from when the collector current reaches 10% of rating until the $V_{CE}$ voltage fall to 10% of rating when the IGBT is turned on. See Fig. 2-2 for details.
Turn-off Time	$t_{off}$	The time from when the input signal voltage level falls below the threshold value until the collector current falls to 10% of rating. See Fig. 2-2 for details.
Turn-off Delay Time	$t_{d(off)}$	The time from when the input signal voltage level falls below the threshold value until the collector current falls to 90% of rating. See Fig. 2-2 for details.
Turn-off Fall Time	$t_f$	The time for the collector current to fall from 90% of rating to 10% of rating when the IGBT is turned off. See Fig. 2-2 for details.
$V_{CE}-I_C$ Cross Time of Turn-off	$t_{c(off)}$	The time from when the $V_{CE}$ voltage reaches 10% of rating until the collector current fall to 10% of rating when the IGBT is turned off. See Fig. 2-2 for details.
Reverse Recovery Time	$t_{rr}$	Time required to reduce the reverse recovery current of FWD to zero. See Fig. 2-2 for details.



Table 2-2 Description of terminology

(2) Control Circuit Block

Item	Symbol	Description
Circuit Current of Low-side	$I_{CCL}$	Consumption current between VCCL and COM.
Circuit Current of High-side	$I_{CCH}$	Consumption current between VCCH(U, V, W) and COM (for each phase).
Circuit current of Bootstrap circuit	$I_{CCHB}$	Consumption current between VB(U)-VS(U), VB(V)-VS(V), and VB(W)-VS(W) (for each phase).
Input Signal Threshold Voltage	$V_{th(on)}$	Input signal threshold voltage that turns on the IGBT. <sup>*1</sup>
	$V_{th(off)}$	Input signal threshold voltage that turns off the IGBT. <sup>*1</sup>
Input Signal Threshold Hysteresis Voltage	$V_{th(hys)}$	Hysteresis voltage between $V_{th(on)}$ and $V_{th(off)}$ . <sup>*1</sup>
Operational Input Pulse Width of Turn-on	$t_{N(on)}$	Control signal pulse width required to turn-on the IGBT. Refer to Chapter 3.4 for details.
Operational Input Pulse Width of Turn-off	$t_{N(off)}$	Control signal pulse width required to turn-off the IGBT. Refer to Chapter 3.4 for details.
Input Current	$I_{IN}$	Current flowing between IN(HU,HV,HW,LU,LV,LW) and COM.
Input Pull-down Resistance	$R_{IN}$	Resistance of built-in resistor between IN(HU,HV,HW,LU,LV,LW) and COM. (for each phase).
Fault Output Voltage	$V_{FO(H)}$	VFO output voltage during normal operation (low-side protection function is not activated). External pull-up resistor = 10kΩ.
	$V_{FO(L)}$	VFO output voltage when low-side protection function is activated.
Fault Output Pulse Width	$t_{FO}$	The period during which VFO continues to output after low-side protection function is activated. Refer to Chapter 3.6 for details.
Overcurrent Protection Voltage Level	$V_{IS(ref)}$	Overcurrent protection threshold voltage of IS. Refer to Chapter 3.5 for details.
Overcurrent Protection Delay Time	$t_d (IS)$	The time from overcurrent condition is detected until the collector current falls below 50% of rating. Refer to Chapter 3.5 for details.
Overcurrent Trip Level	$I_{oc}$	The current value that can be detected when a specified sense resistor Rsc is connected between VSC and COM without connecting external shunt resistors to N(U), N(V), and N(W).
Output Voltage of Temperature Sensor	$V_{(temp)}$	TEMP output voltage. Applied to temperature sensor output model. Refer to Fig. 2-3 and Chapter 3.7 for details.
Pull down Resistance of TEMP terminal	$R_{(temp)}$	Resistance value at which the temperature characteristic of TEMP output voltage becomes linear below room temperature.
Overheating Protection Temperature	$T_{OH}$	Tripping temperature of overheating protection by LVIC. All low-side IGBTs are shut down when the temperature exceeds this threshold. Refer to Figure 2-3 and Chapter 3.8 for details.
$T_{OH}$ Hysteresis	$T_{OH(hys)}$	Hysteresis temperature that does not reset the protection status during overheating protection. Refer to Figure 2-3 and Chapter 3.8 for details. $T_{OH}$ and $T_{OH(hys)}$ are applied to overheating protection model.

<sup>\*1</sup> If the pulse width of the input signal is less than  $t_{N(on)}$  or  $t_{N(off)}$ , the IPM might make incorrect response.

Table 2-2 Description of terminology

(2) Control Circuit Block (continued)

Item	Symbol	Description
$V_{CC}$ Under Voltage Trip Level of Low-side	$V_{CCL(OFF)}$	Tripping voltage of under voltage protection of low-side control power supply. When $V_{CCL}$ falls below the threshold voltage, all low-side IGBTs are shut down. Refer to Chapter 3.1 for details.
$V_{CC}$ Under Voltage Reset Level of Low-side	$V_{CCL(ON)}$	Reset voltage that resets the under voltage protection of low-side control power supply. Refer to Chapter 3.1 for details.
$V_{CC}$ Under Voltage Hysteresis of Low-side	$V_{CCL(hys)}$	Hysteresis voltage between $V_{CCL(OFF)}$ and $V_{CCL(ON)}$ .
$V_{CC}$ Under Voltage Trip Level of High-side	$V_{CCH(OFF)}$	Tripping voltage of under voltage protection of high-side control power supply. When $V_{CCH(U)}$ , $V_{CCH(V)}$ or $V_{CCH(W)}$ falls below the threshold voltage, the corresponding high-side IGBTs are shut down. Refer to Chapter 3.1 for details.
$V_{CC}$ Under Voltage Reset Level of High-side	$V_{CCH(ON)}$	Reset voltage that resets the under voltage protection of high-side control power supply. Refer to Chapter 3.1 for details.
$V_{CC}$ Under Voltage Hysteresis of High-side	$V_{CCH(hys)}$	Hysteresis voltage between $V_{CCH(OFF)}$ and $V_{CCH(ON)}$ .
$V_B$ Under Voltage Trip Level	$V_{B(OFF)}$	Tripping voltage of under voltage protection of high-side bias voltage. When $V_{B(U)}$ , $V_{B(V)}$ , $V_{B(W)}$ falls below the threshold voltage, the corresponding high-side IGBT is shut down. Refer to Chapter 3.2 for details.
$V_B$ Under Voltage Reset Level	$V_{B(ON)}$	Reset voltage that resets the under voltage protection of high-side bias voltage. Refer to Chapter 3.2 for details.
$V_B$ Under Voltage Hysteresis	$V_{B(hys)}$	Hysteresis voltage between $V_{B(OFF)}$ and $V_{B(ON)}$ .
Forward Voltage of Bootstrap Diode	$V_{F(BSD)}$	Forward voltage when a specified forward current flows through BSD.
Built-in Limiting Resistance	$R_{(BSD)}$	Built-in current limiting resistor resistance value of bootstrap circuit.

Table 2-2 Description of terminology

## (3) Thermal Characteristics

Item	Symbol	Description
Junction to Case Thermal Resistance (per single IGBT)	$R_{th(j-c)}_{IGBT}$	Thermal resistance from junction to case of a single IGBT.
Junction to Case Thermal Resistance (per single Diode)	$R_{th(j-c)}_{FWD}$	Thermal resistance from junction to case of a single FWD.

## (4) Mechanical Characteristics

Item	Symbol	Description
Mounting Torque of Screws	$M_S$	Maximum screwing torque when mounting the IPM to a cooling body with specified screws.
Heat-sink Side Flatness	-	Flatness of the IMS's aluminum surface. Refer to Fig. 2-4.
Weight	-	Weight of a single IPM.
Resistance to Soldering Heat	-	Number of times of solder heat resistance under specified conditions.

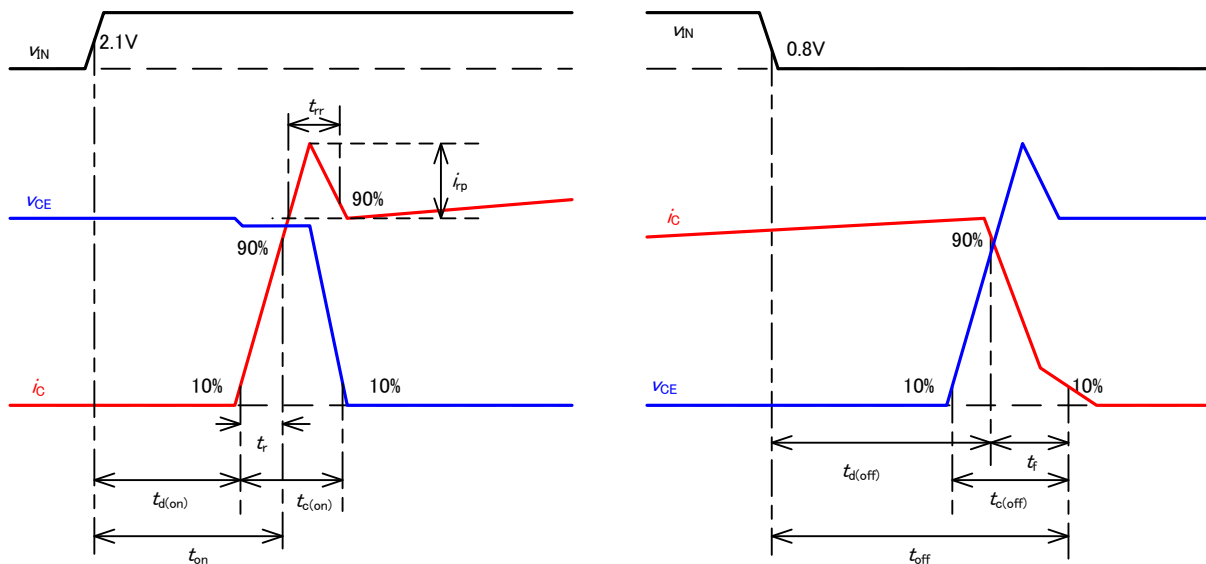

Fig. 2-2 Switching waveforms

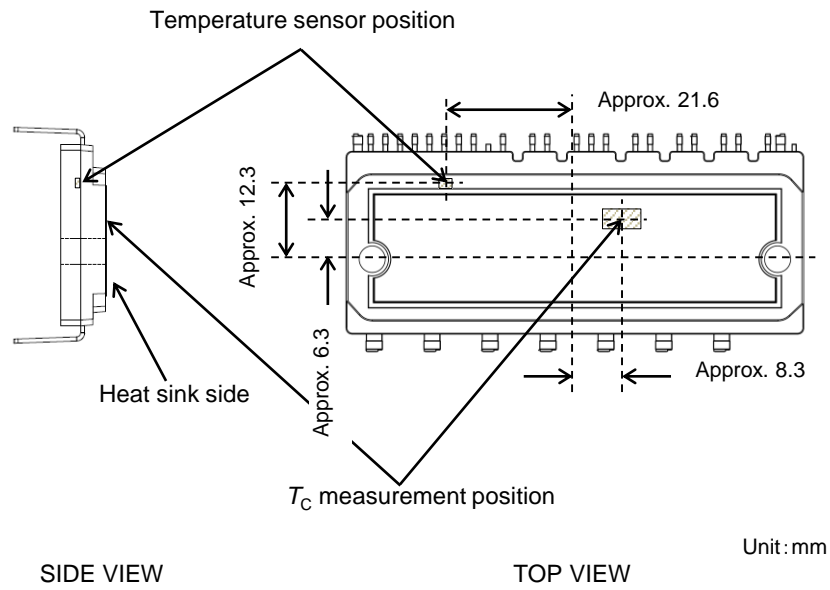

Fig. 2-3 Temperature sensor position and  $T_c$  measurement position

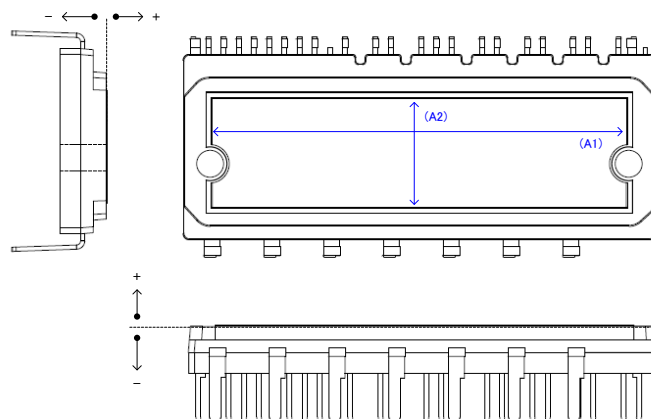

Fig. 2-4 Measurement point of heat sink surface flatness

## Chapter 3 Details of Control & Protection Functions

1. Control Power Supply, VCCH(U,V,W), VCCL, COM	3-2
2. High-side Bias Voltage, VB(U,V,W), VS(U,V,W)	3-6
3. Function of Built-in BSDs (Bootstrap Diodes)	3-9
4. Signal Input, IN(HU,HV,HW), IN(LU,LV,LW)	3-14
5. Overcurrent Protection Function, IS	3-17
6. Fault Status Output Function, VFO, CFO	3-19
7. Temperature Output Function, TEMP	3-21
8. Overheating Protection Function	3-23

## 1. Control Power Supply, VCCH(U,V,W), VCCL, COM

### 1. Voltage range of control power supply $V_{CCH(U,V,W)}$ , $V_{CCL}$

Please connect 15V DC power supply between VCCH(U), VCCH(V), VCCH(W), VCCL and COM terminals for the control power supply of this IPM. The voltage should be regulated to  $15V \pm 10\%$  for proper operation. Table 3-1 describes the operating state of the IPM for various control power supply voltages. A low impedance capacitor and a high frequency decoupling capacitor should be connected close to the terminals of the power supply.

High frequency noise on the power supply might cause malfunction of the internal control IC or output erroneous fault signal. To avoid these problems, the maximum amplitude of voltage ripple of the control power supply should be less than  $\pm 1V/\mu s$ .

When connecting external shunt resistor, the potential at the COM terminal is different from that at the N(\*)<sup>\*1</sup> terminal. Please refer all control circuits and power supplies to the COM terminal and not to the N(\*)<sup>\*1</sup> terminals. If circuits are improperly connected, current might flow through the shunt resistor and cause improper operation of the short-circuit protection function. In general, it is recommended to set the COM terminal as the ground potential in the PCB layout.

The main control power supply is also connected to the bootstrap circuit, which provide floating power supplies for gate driving of high-side IGBTs.

When high side control power supply voltage  $V_{CCH(U)}$ ,  $V_{CCH(V)}$  or  $V_{CCH(W)}$  falls below  $V_{CCH(OFF)}$ , only the IGBT which UV protection is triggered is turned-off regardless of input signal condition.

When low side control power supply voltage  $V_{CCL}$  falls below  $V_{CCL(OFF)}$ , all low-side IGBTs are turned-off regardless of input signal condition.

Table 3-1  $V_{CCH(U,V,W)}$ ,  $V_{CCL}$  voltage range versus operating state of IPM

Voltage range [V]	Operating state of IPM
0 ~ 4	The IPM does not operate. UV protection and alarm output do not function. dv/dt noise on P-N(*) power supply might cause malfunction to the IGBTs.
4 ~ 13	The IPM starts to operate. UV protection is activated. Input signals are blocked and fault output is generated.
13 ~ 13.5	UV protection is reset. Low-side IGBTs perform switching operation according to the input signal. Due to the driving voltage is below the recommended range, the conduction losses and switching losses of the IGBTs are larger than normal. The high-side IGBTs do not operate until $V_{B(*)}$ <sup>*2</sup> reach $V_{B(ON)}$ after initial charging.
13.5 ~ 16.5	The IPM operates under recommended operating conditions.
16.5 ~ 20	Due to the driving voltage is above the recommended range, IGBTs are switching faster, which increases the system noise. Even with proper overcurrent protection design, the peak short-circuit current might be too large and lead to destruction.
Over 20	The IPM might be destroyed. It is recommended to connect a Zener diode to each control power supply terminal if necessary.

\*1 N(\*) : N(U),N(V),N(W) \*2  $V_{B(*)}$  :  $V_{B(U)}$ ,  $V_{B(V)}$ ,  $V_{B(W)}$

## 2. Under voltage (UV) protection of control power supply $V_{CCH(U,V,W)}$ , $V_{CCL}$

Fig.3-1 shows the UV protection circuit of high-side and low-side control power supply ( $V_{CCH(U,V,W)}$ ,  $V_{CCL}$ ). Fig.3-2 and Fig.3-3 show the UV protection operation sequence.

As shown in Fig.3-1, diodes are electrically connected to the VCCH(U,V,W)-COM and VCCL-COM terminals. These diodes are built-in to protect the IPM from input surge voltage. Do not use these diodes for voltage clamp purpose as it might damage the IPM.

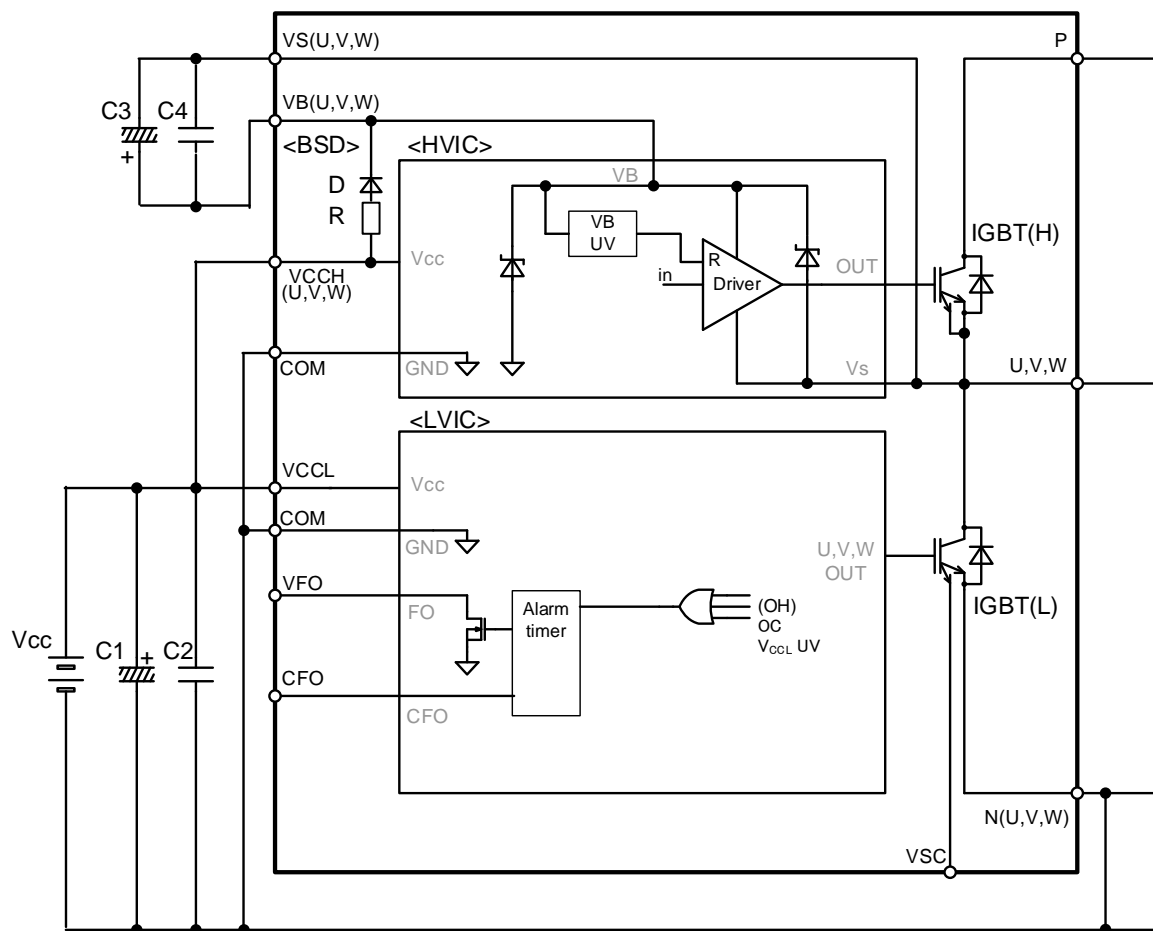

Fig. 3-1 UV protection circuit of high-side and low-side control power supply

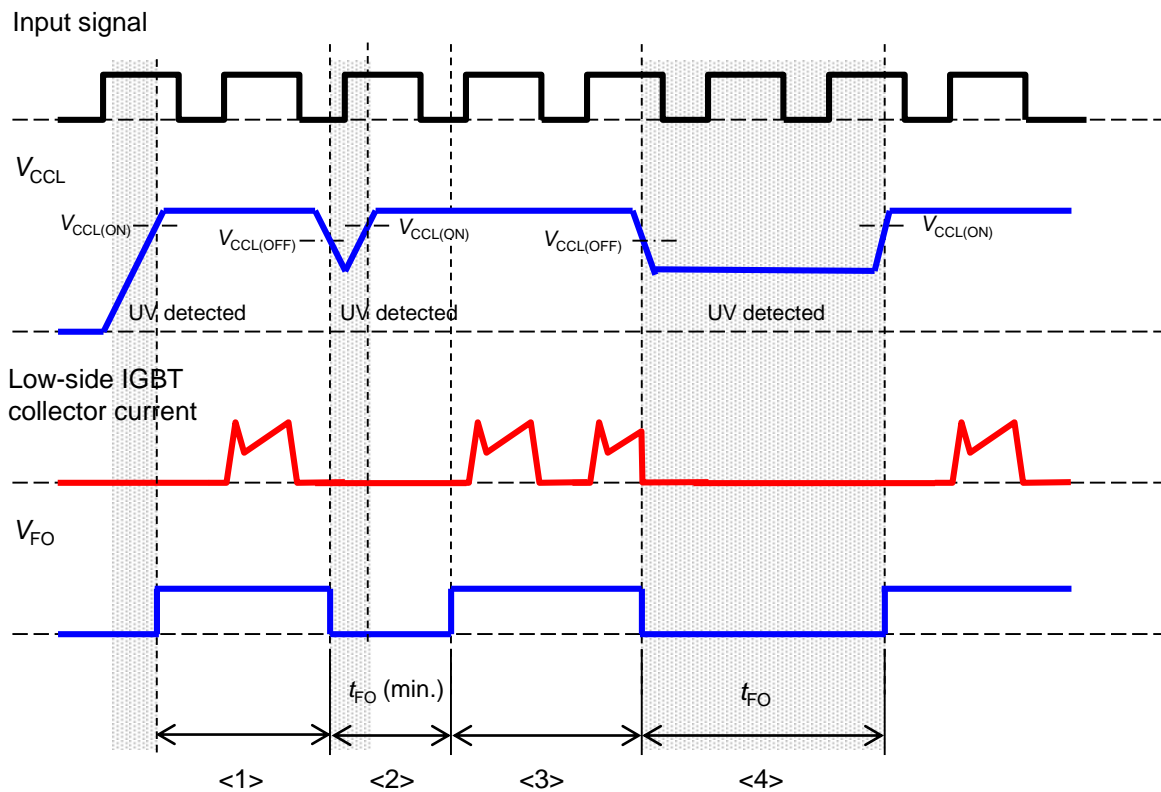

Fig. 3-2 UV protection operation sequence of  $V_{CCL}$

When  $V_{CCL}$  is below 4V, UV and fault output are not activated.

- <1> When  $V_{CCL}$  is below  $V_{CCL(ON)}$ , all low-side IGBTs are OFF.  
When  $V_{CCL}$  exceeds  $V_{CCL(ON)}$ , the fault output voltage  $V_{FO}$  is reset from L level to H level.  
LVIC starts switching operation from the next input signal.
- <2> When  $V_{CCL}$  falls below  $V_{CCL(OFF)}$ , the fault output voltage  $V_{FO}$  becomes L level.  
All low-side IGBTs are turned off.  
If the voltage drop period is less than  $t_{FO(min.)}$ , the minimum fault output pulse width  $t_{FO(min.)}$  is generated. During that period, all low-side IGBTs are turned off regardless of input signal condition.
- <3> UV protection is reset after  $t_{FO}$  when  $V_{CCL}$  exceeds  $V_{CCL(ON)}$ .  
Fault output voltage  $V_{FO}$  is also reset.  
LVIC restarts switching operation from the next input signal.
- <4> If the voltage drop period is longer than  $t_{FO}$ , fault output pulse width with the same duration is output. During that period, all low-side IGBTs are turned off regardless of input signal condition.



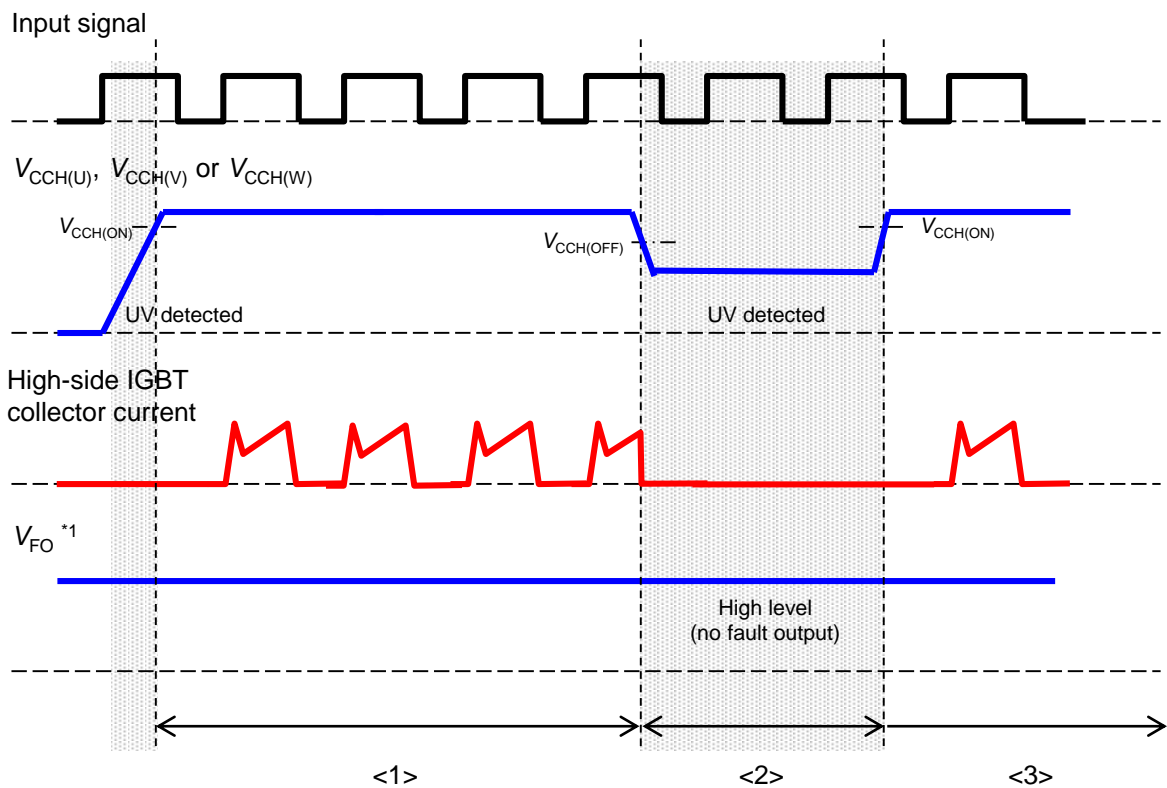

Fig. 3-3 UV protection operation sequence of  $V_{CCH(U,V,W)}$

- <1> When  $V_{CCH(U)}$ ,  $V_{CCH(V)}$  or  $V_{CCH(W)}$  is below  $V_{CCH(ON)}$ , the corresponding high-side IGBT is OFF.  
When  $V_{CCH(U)}$ ,  $V_{CCH(V)}$  or  $V_{CCH(W)}$  exceeds  $V_{CCH(ON)}$ , HVIC starts switching operation from the next input signal.  
The fault output voltage  $V_{FO}$  is H level regardless of  $V_{CCH(U)}$ ,  $V_{CCH(V)}$  or  $V_{CCH(W)}$ . \*1
- <2> When  $V_{CCH(U)}$ ,  $V_{CCH(V)}$  or  $V_{CCH(W)}$  falls below  $V_{CCH(OFF)}$ , the corresponding high-side IGBT is turned off.  
The fault output voltage  $V_{FO}$  remains at H level.
- <3> After UV protection is reset, HVIC restarts switching operation from the next input signal.

\*1 : The fault output does not depend on the bias condition of the HVIC.

## 2. High-side Bias Voltage, $V_{B(U,V,W)}$ , $V_{S(U,V,W)}$

### 1. Voltage range of high-side bias voltage $V_{B(*)}$

The  $V_{B(*)}$  voltage, which is the voltage difference between  $V_{B(U,V,W)}$  and  $V_{S(U,V,W)}$ , is the high-side bias voltage for the built-in HVICs. HVIC can drive the high-side IGBTs if the voltage is in the range of 13.0~18.5V. The IPM has UV protection for  $V_{B(*)}$  to ensure that the HVICs do not drive the high-side IGBTs when  $V_{B(*)}$  voltage drops below a specified voltage. This function prevents the IGBT from operating in a high dissipation mode. Please note that the UV function turns-off only the IGBT of the triggered phase. There is no fault output.

In the case of using bootstrap circuit, the high-side IGBT bias voltage can be generated with the control power supply. Conventionally, high-side IGBT drive circuit requires three independent floating power supplies in addition to the control power supplies.

The high-side bias voltage is charged when the low-side IGBT is turned on or when freewheel current flows at the low-side FWD. Table 3-2 describes the operating state of the IPM for various high-side bias voltages. Connect a low impedance electrolytic capacitor and a smoothing capacitor with good frequency characteristics to the high-side bias voltage as close as possible to the terminals in order to prevent malfunction of this IPM caused by high frequency noise.

When high-side bias voltage  $V_{B(U)}$ ,  $V_{B(V)}$ , or  $V_{B(W)}$  falls below  $V_{B(OFF)}$ , only the high-side IGBT which UV protection is triggered is turned-off regardless of the input signal condition.

Table 3-2  $V_{B(*)}$  voltage range versus operating state of IPM

Voltage range [V]	Operating state of IPM
0 ~ 4	The IPM does not operate. UV protection does not function. dv/dt noise on P-N(*) power supply might cause malfunction to the IGBTs.
4 ~ 12.5	The IPM starts to operate. UV protection is activated. Input signals are blocked.
12.5 ~ 13	UV protection is reset. High-side IGBTs perform switching operation according to the input signal. Due to the driving voltage is below the recommended range, the conduction losses and switching losses of the IGBTs are larger than normal.
13 ~ 18.5	The IPM operates under recommended operating conditions.
18.5 ~ 20	Due to the driving voltage is above the recommended range, IGBTs are switching faster, which increases the system noise. Even with proper overcurrent protection design, the peak short-circuit current might be too large and lead to destruction.
Over 20	The IPM might be destroyed. It is recommended to connect a Zener diode to each control power supply terminal if necessary.

## 2. Under voltage (UV) protection of high-side bias voltage $V_{B(*)}$

Fig.3-4 shows the UV protection circuit of high-side bias voltage  $V_{B(*)}$ .

Fig.3-5 shows the UV protection operation sequence of  $V_{B(*)}$ .

As shown in Fig.3-4, diodes are electrically connected to the  $VB(U,V,W)$ ,  $VS(U,V,W)$  and  $VB(U,V,W)$ -COM terminals. These diodes are built-in to protect the IPM from input surge voltage. Do not use these diodes for voltage clamp purpose as it might damage the IPM.

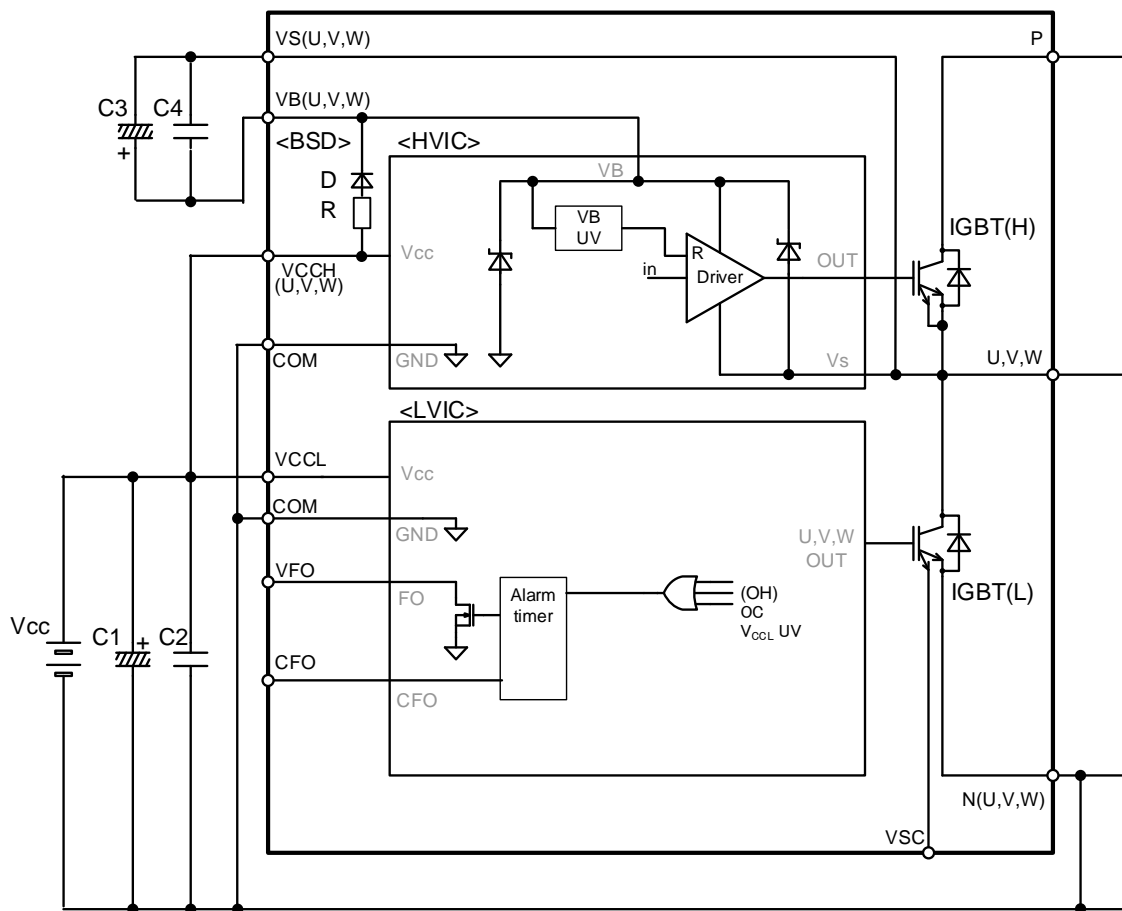

Fig. 3-4 UV protection circuit of high-side bias voltage

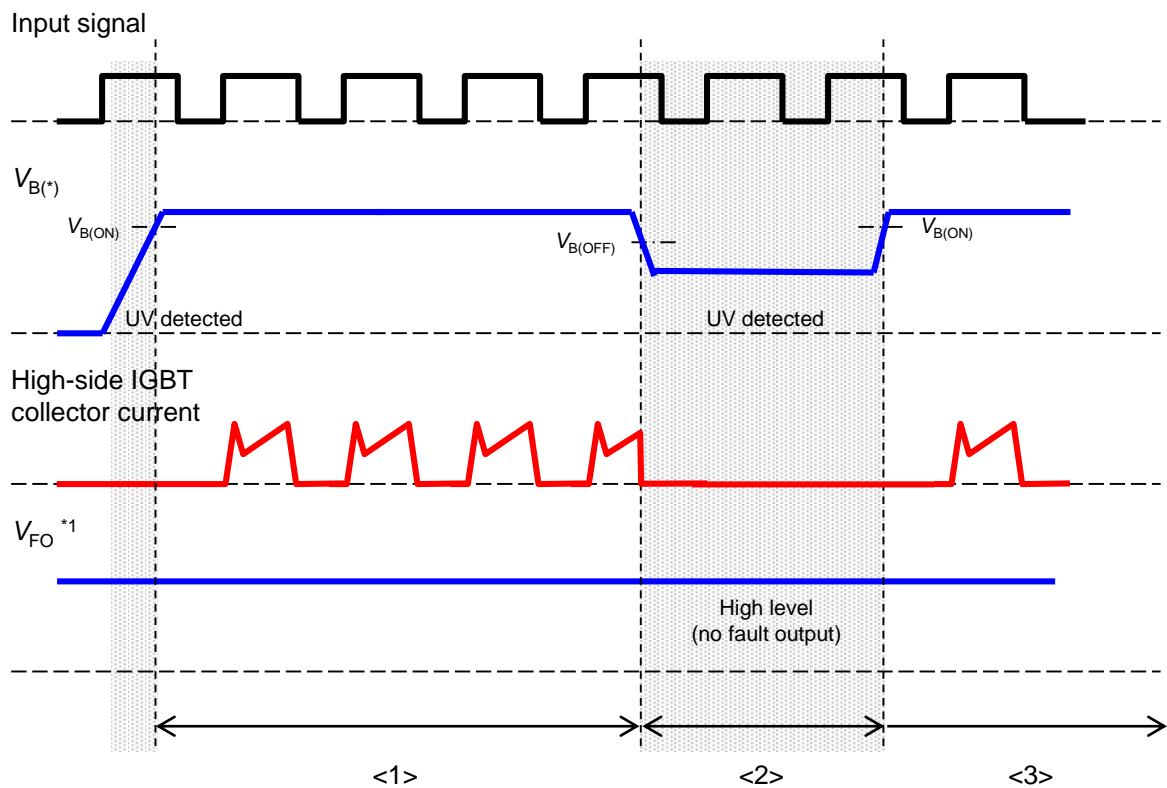

Fig. 3-5 UV protection operation sequence of  $V_{B(*)}$

- <1> When  $V_{B(U)}$ ,  $V_{B(V)}$  or  $V_{B(W)}$  is below  $V_{B(ON)}$ , the corresponding high-side IGBT is OFF.  
When  $V_{B(*)}$  exceeds  $V_{B(ON)}$ , HVIC starts switching operation from the next input signal.  
The fault output voltage  $V_{FO}$  is H level regardless of  $V_{B(*)}$ . \*1
- <2> When  $V_{B(U)}$ ,  $V_{B(V)}$  or  $V_{B(W)}$  falls below  $V_{B(OFF)}$ , the corresponding high-side IGBT is turned off.  
The fault output voltage  $V_{FO}$  remains at H level.
- <3> After UV protection is reset, HVIC restarts switching operation from the next input signal.

\*1 : The fault output does not depend on the bias condition of the HVIC.

### 3. Function of Built-in BSDs (Bootstrap Diodes)

There are several ways to generate high-side bias voltage  $V_{B(*)}$  ( $V_B(U)-V_S(U)$ ,  $V_B(V)-V_S(V)$ ,  $V_B(W)-V_S(W)$  voltage). This IPM can configure a bootstrap circuit by using the built-in BSDs. When configuring the bootstrap circuit, it is necessary to set the duty ratio and on-time according to the bootstrap capacitor and the charging operation conditions.

#### 1. Bootstrap circuit operation

<Low-side IGBT ON (Fig. 3-6) : timing chart (Fig. 3-7)>

When low-side IGBT is ON, the high-side bias voltage  $V_{B(*)}(t1)$  from the charging operation of the bootstrap capacitor can be expressed by the following equations.

$$V_{B(*)}(t1) = V_{CC} - V_F - V_{CE(sat)} - I_B \cdot R \quad \dots \text{transient state}$$

$$V_{B(*)}(t1) \approx V_{CC} \quad \dots \text{steady state}$$

$V_F$  : Forward voltage of BSD (D)

$V_{CE(sat)}$  : Saturation voltage of low-side IGBT

$R$  : Bootstrap circuit resistance (R)

$I_B$  : Charging current of bootstrap circuit

When low-side IGBT is turned off, the motor current flows to the high-side FWD. When the  $V_S$  potential rises above  $V_{CC}$ , the charging of C stops, and  $V_{B(*)}$  gradually decreases due to current consumption by the high-side control power supply.

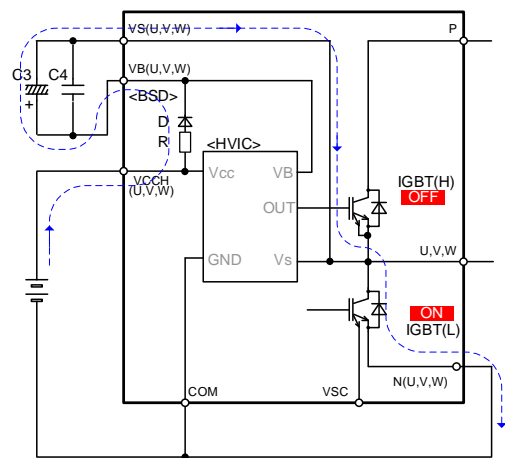

Fig. 3-6 Circuit diagram of charging operation when low-side IGBT is ON

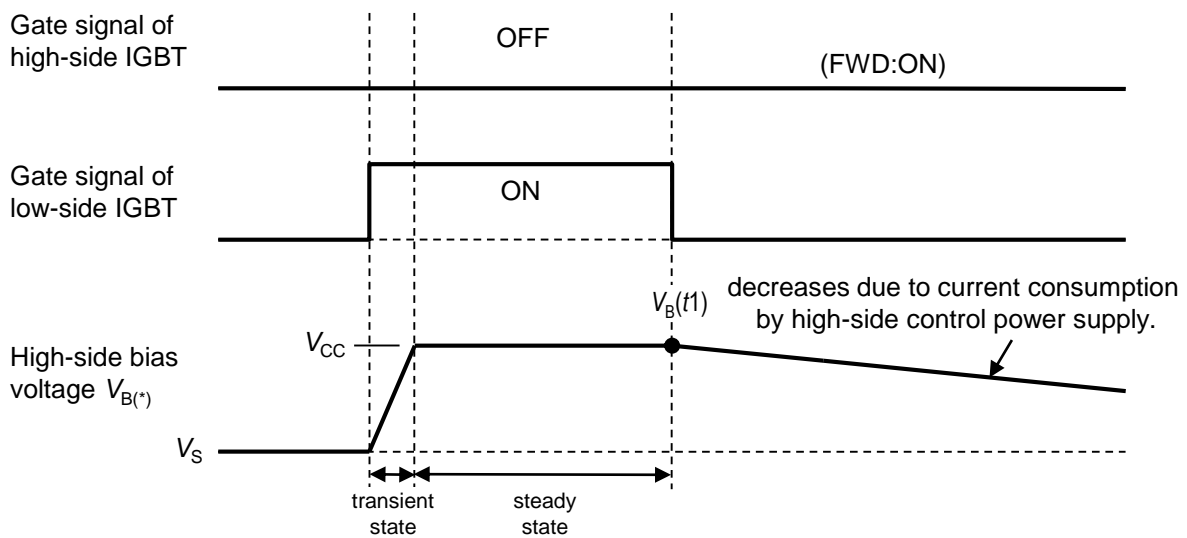

Fig. 3-7 Timing chart of charging operation when low-side IGBT is ON

<Low-side IGBT OFF, low-side FWD ON (freewheeling)  
(Fig. 3-8) : sequence (Fig. 3-9)>

When low-side IGBT is OFF and low-side FWD is ON, freewheel current flows through the low-side FWD. The high-side bias voltage  $V_{B(*)}(t2)$  from the charging operation of the bootstrap capacitor can be expressed by the following equations.

$$V_{B(*)}(t2) = V_{CC} - V_F + V_{F(FWD)} - I_B \cdot R \dots\dots \text{transient state}$$

$$V_{B(*)}(t2) \approx V_{CC} \dots\dots \text{steady state}$$

- $V_F$  : Forward voltage of BSD (D)
- $V_{F(FWD)}$  : Forward voltage of low-side FWD
- $R$  : Bootstrap circuit resistance (R)
- $I_B$  : Charging current of bootstrap circuit

When both the low-side and high-side IGBTs are OFF, the regenerative current flows through the low-side FWD. Therefore, the  $V_S$  potential drops to  $-V_F$  of FWD, and the bootstrap capacitor is recharged. When the high-side IGBT is turned on and the  $V_S$  potential rises above  $V_{CC}$ , the charging of C stops, and  $V_{B(*)}$  gradually decreases due to current consumption by the high-side control power supply.

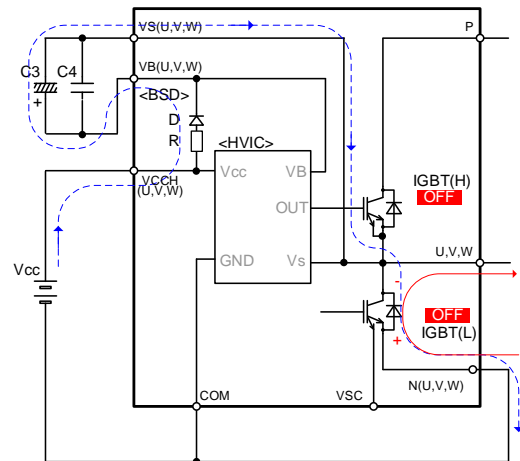

Fig. 3-8 Circuit diagram of charging operation when low-side FWD is ON

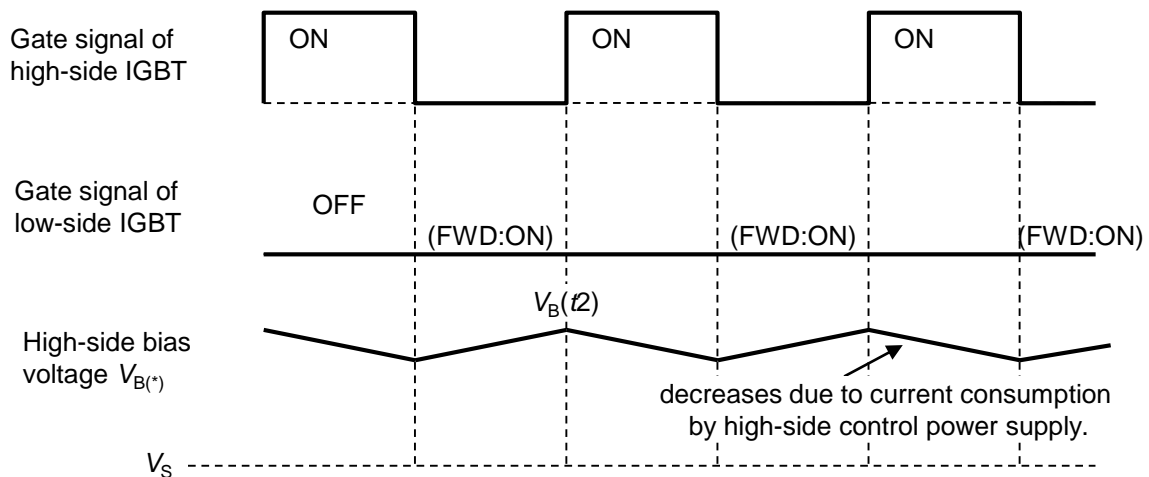

Fig. 3-9 Timing chart of charging operation when low-side FWD is ON

## 2. Setting of bootstrap operating conditions

### 2.1 Setting the bootstrap capacitance and minimum ON/OFF pulse width

The bootstrap capacitance can be determined by the following equation:

$$C = I_{CCHB} \cdot \frac{t1}{dV}$$

- \*  $t1$  : the maximum ON pulse width of the high-side IGBT
- \*  $I_{CCHB}$  : consumption current of high-side drive power supply (temperature and frequency dependent)
- \*  $dV$  : allowable discharge voltage of  $V_{B(*)}$  (refer to Fig.3-10)

Certain margin should be added to the calculated capacitance.

In general, select a capacitor that is two to three times of the calculated result.

The recommended minimum ON pulse width ( $t2$ ) of the low-side IGBT should be determined such that the time constant  $R \cdot C$  will enable the discharged voltage ( $dV$ ) to be fully recharged again during the ON period.

In the case of the control mode which only the high-side IGBT performs switching operation (Fig. 3-10), the time constant should be set so that the discharged voltage can be fully recharged again during the high-side IGBT OFF (low-side FWD ON) period.

The minimum pulse width is decided by the minimum ON pulse width of the low-side IGBT, or the minimum OFF pulse width of the high-side IGBT, whichever is longer.

$$t2 \geq \frac{R \cdot C \cdot dV}{V_{CC} - V_{B(\min)}}$$

- \*  $t2$  : Minimum ON pulse width of low-side IGBT
- \*  $R$  : Bootstrap circuit resistance  $R_{(BSD)}$  (refer to Fig. 3-11, Fig. 3-12)
- \*  $C$  : Bootstrap capacitance
- \*  $dV$  : Allowable discharge voltage of  $V_{B(*)}$
- \*  $V_{CC}$  : Voltage of high-side, low-side control power supply (ex.15V)
- \*  $V_{B(\min)}$  : Minimum voltage of high-side bias voltage (add margin to  $V_{B(ON)}$ , ex.14V)

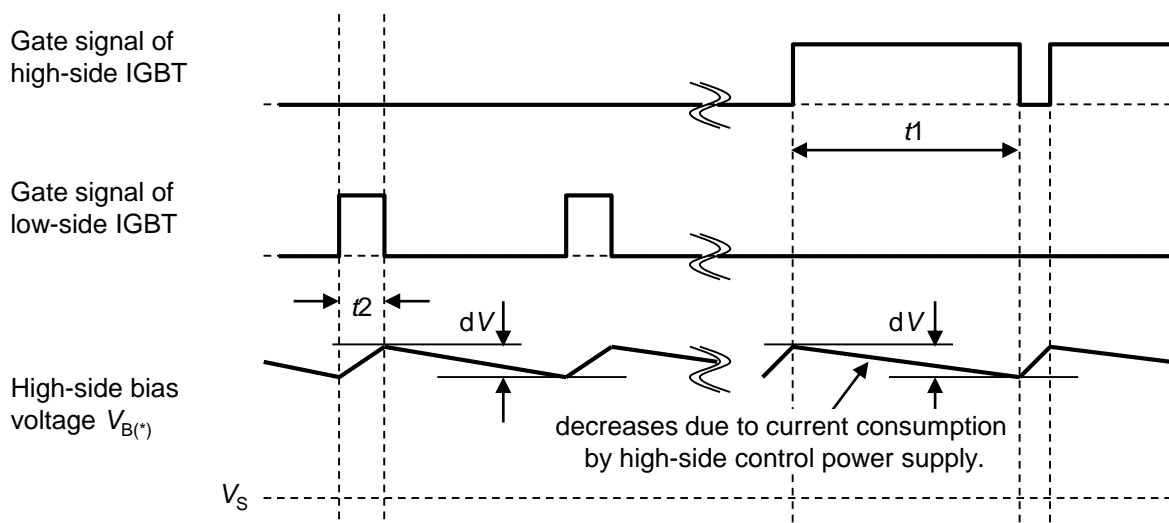

Fig. 3-10 Timing chart of charging and discharging operation

The bootstrap diode has built-in current limiting resistor of 20Ω (typ.). Fig. 3-11 and Fig. 3-12 show the  $V_F$ - $I_F$  characteristics of the bootstrap diode.

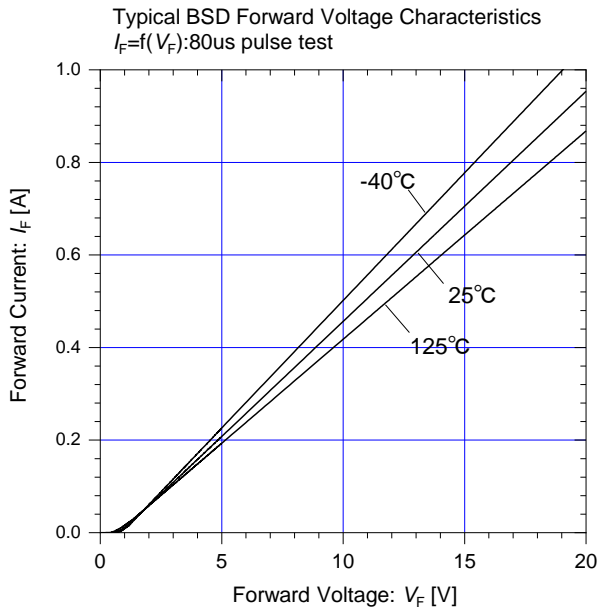

Fig. 3-11  $V_F$ - $I_F$  characteristic of BSD

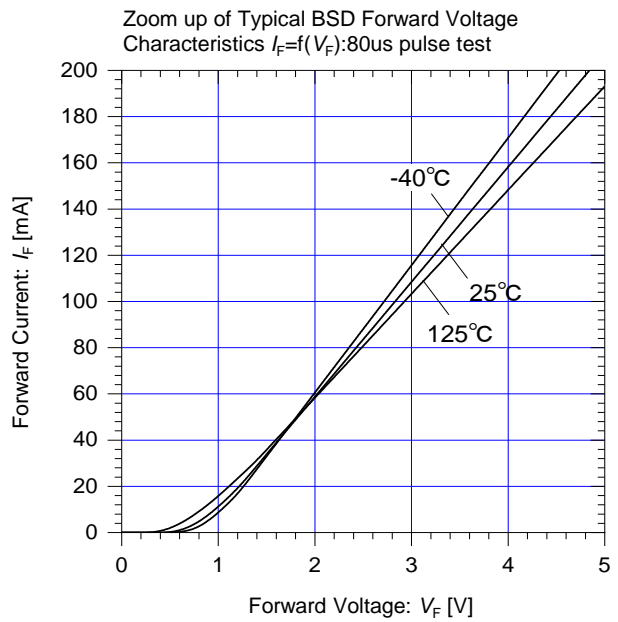

Fig. 3-12  $V_F$ - $I_F$  characteristic of BSD  
(zoom at low current range)



## 2.2 Setting the initial charging of bootstrap capacitor

Initial charging of the bootstrap capacitor is required to start the inverter.

The pulse width or the number of pulses should be long enough to fully charge the bootstrap capacitor.

For reference, it takes about 10ms to charge a 47uF capacitor through the built-in bootstrap diode.

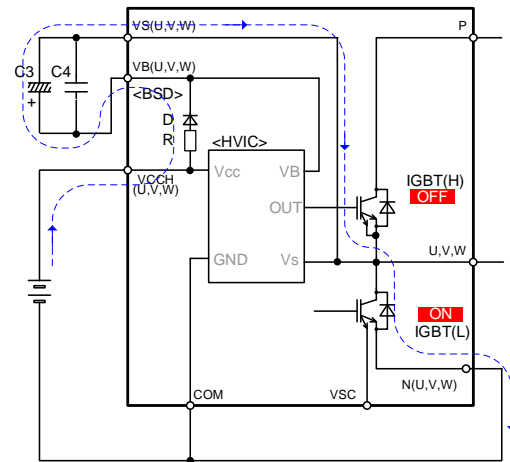

Fig. 3-13 Circuit diagram of initial charging operation

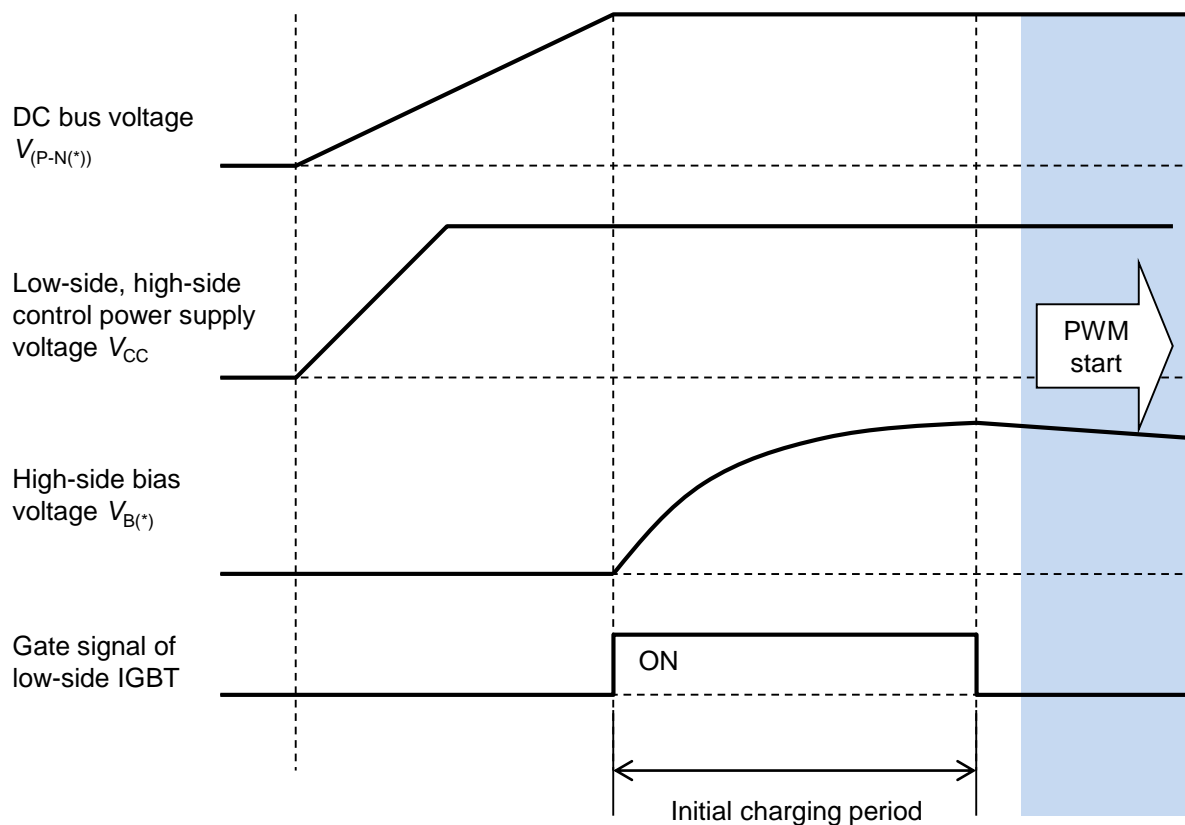

Fig. 3-14 Timing chart of initial charging operation

## 4. Signal Input, IN(HU,HV,HW), IN(LU,LV,LW)

### 1. Input terminals connection

Fig. 3-15 shows an example of interface circuit between MPU and the IPM. The input terminals can be connected directly to the MPU. The input terminals have built-in pull-down resistors, so there is no need for external pull-down resistors. Also, the input logic is high active, thus there is no need for external pull-up resistors.

Insert RC filter circuit as shown by the dotted line in Fig. 3-15 if noise is superimposed on long signal wire. Adjust the RC constant according to the PWM control method and the wiring pattern of the printed circuit board.

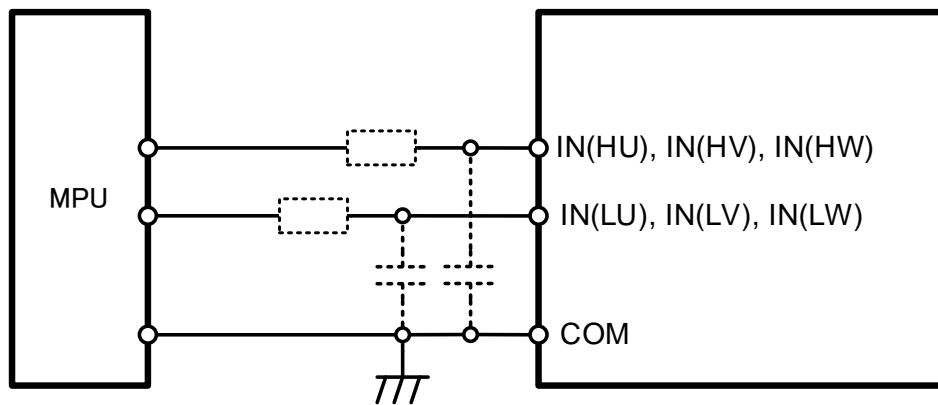

Fig. 3-15 Recommended MPU I/O interface circuit of IN(HU,HV,HW), IN(LU,LV,LW) terminals

## 2. Input terminals circuit

The input logic of this IPM is high active. Thus, the input signal has no restriction on the power supply startup and shutdown sequence, so the system is fail safe. In addition, as shown in Fig. 3-16, the input terminals have built-in pull-down resistors, thus there is no need for external pull-down resistors, reducing the number of system components. Furthermore, a 3.3V-class MPU can be connected directly since the input signal threshold voltage is low.

In the case of connecting an external filter resistor between the MPU and the input terminal of the IPM, make sure that the input terminal voltage is above the input signal threshold voltage in consideration of the built-in pull-down resistor.

As shown in Fig.3-16, diodes are electrically connected to the VCCL-IN(HU,HV,HW,LU,LV,LW) and IN(HU,HV,HW,LU,LV,LW)-COM terminals. These diodes are built-in to protect the IPM from input surge voltage. Do not use these diodes for voltage clamp purpose as it might damage the IPM.

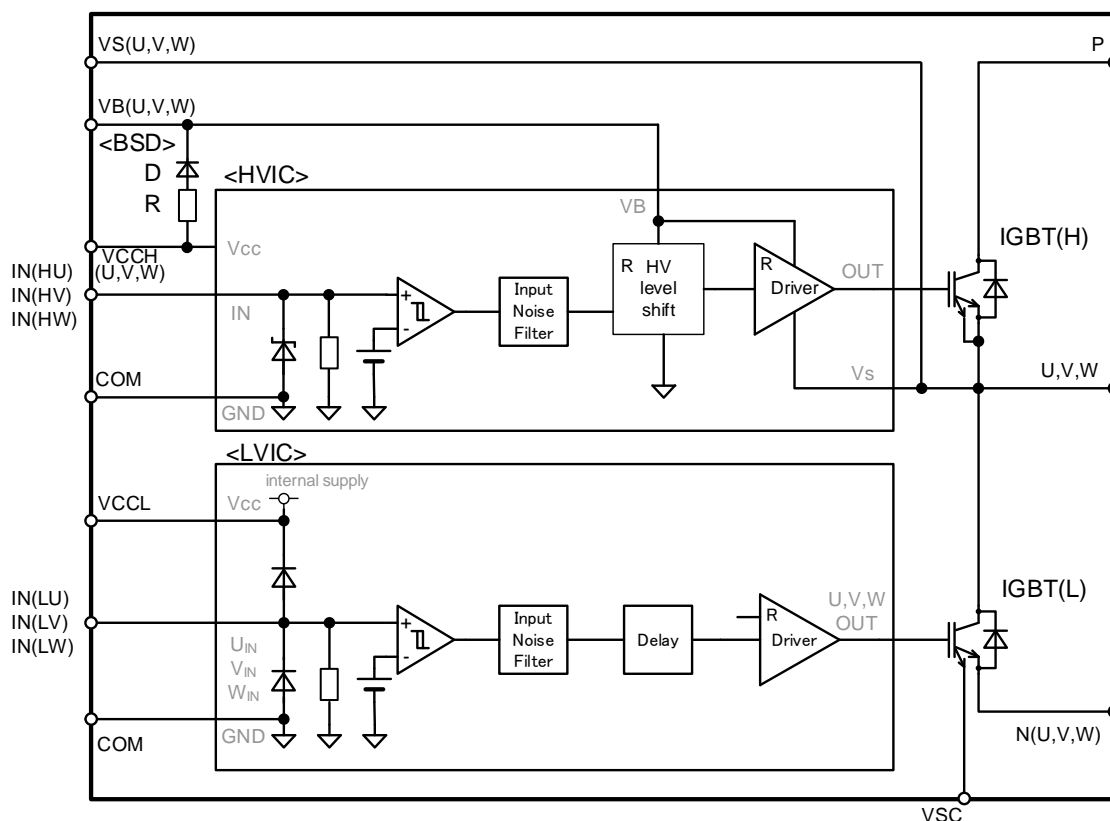

Fig.3-16 Circuit of IN(HU,HV,HW), IN(LU,LV,LW) terminals

### 3. IGBT drive state and input signal pulse width

$t_{N(on)}$  is the recommended minimum ON pulse width required to turn-on the IGBT without malfunction, and  $t_{N(off)}$  is the recommended minimum OFF pulse width required to turn-off the IGBT without malfunction. Fig. 3-17 and Fig. 3-18 show the IGBT drive state at various input signal pulse width.

A : IGBT might turn-on even when the input signal ON pulse width is less than minimum  $t_{N(on)}$ .

In the case of input signal ON pulse width is less than minimum  $t_{N(on)}$  and a voltage below -5V is applied between U-COM, V-COM, W-COM terminals, not only the IPM might be broken but also the IGBT might not turn-off due to malfunction of the control circuit.

B : In steady state operation. IGBT operates in the linear region.

C : IGBT might turn-off even when the input signal OFF pulse width is less than minimum  $t_{N(off)}$ .

In the case of input signal OFF pulse width is less than minimum  $t_{N(off)}$  and a voltage below -5V is applied between U-COM, V-COM, W-COM terminals, not only the IPM might be broken but also the IGBT might not turn-on due to malfunction of the control circuit.

D : In steady state operation. IGBT is completely turned off.

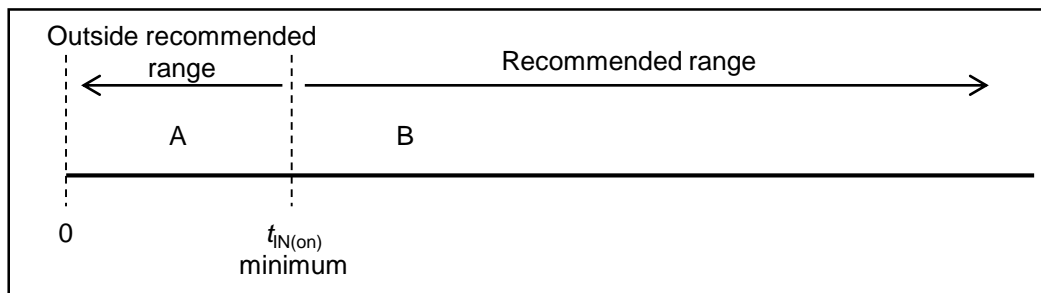

Fig. 3-17 IGBT drive state versus input signal ON pulse width

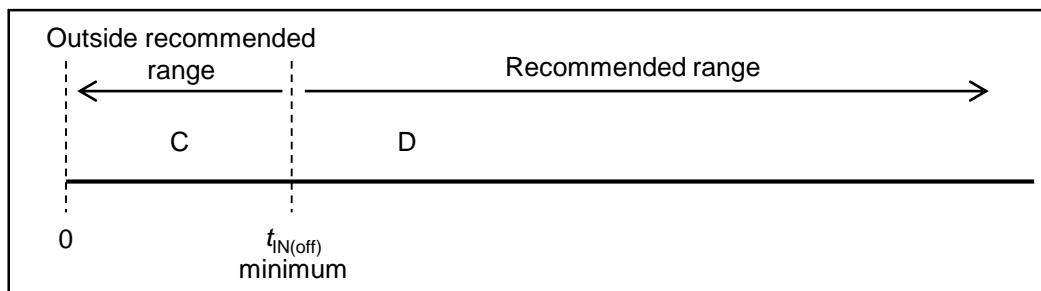

Fig. 3-18 IGBT drive state versus input signal OFF pulse width

## 5. Overcurrent Protection Function, IS

### 1. Input terminals connection

The overcurrent (OC) protection works by detecting the voltage generated at the external shunt resistor connected between N(\*) \*1 and COM terminal, or the voltage generated at the sense resistor connected between VSC and COM terminal, and input to IS terminal. When this voltage exceeds  $V_{IS(ref)}$ , all low-side IGBTs are turned-off and fault output is generated.

Fig. 3-19 shows the OC protection detection circuit of IS terminal. Fig. 3-20 shows the OC protection operation sequence.

To prevent the IPM from unnecessary operations due to switching noise or recovery current during normal operation, it is recommended to insert an external RC filter (time constant is approximately  $1.1\mu s$ ) to the IS terminal. Keep the wiring between the IPM and the shunt resistor as short as possible too.

As shown in Fig. 3-19, diodes are electrically connected between VCCL-IS and IS-COM terminals. These diodes are built-in to protect the IPM from input surge voltage. Do not use these diodes for voltage clamp purpose as it might damage the IPM.

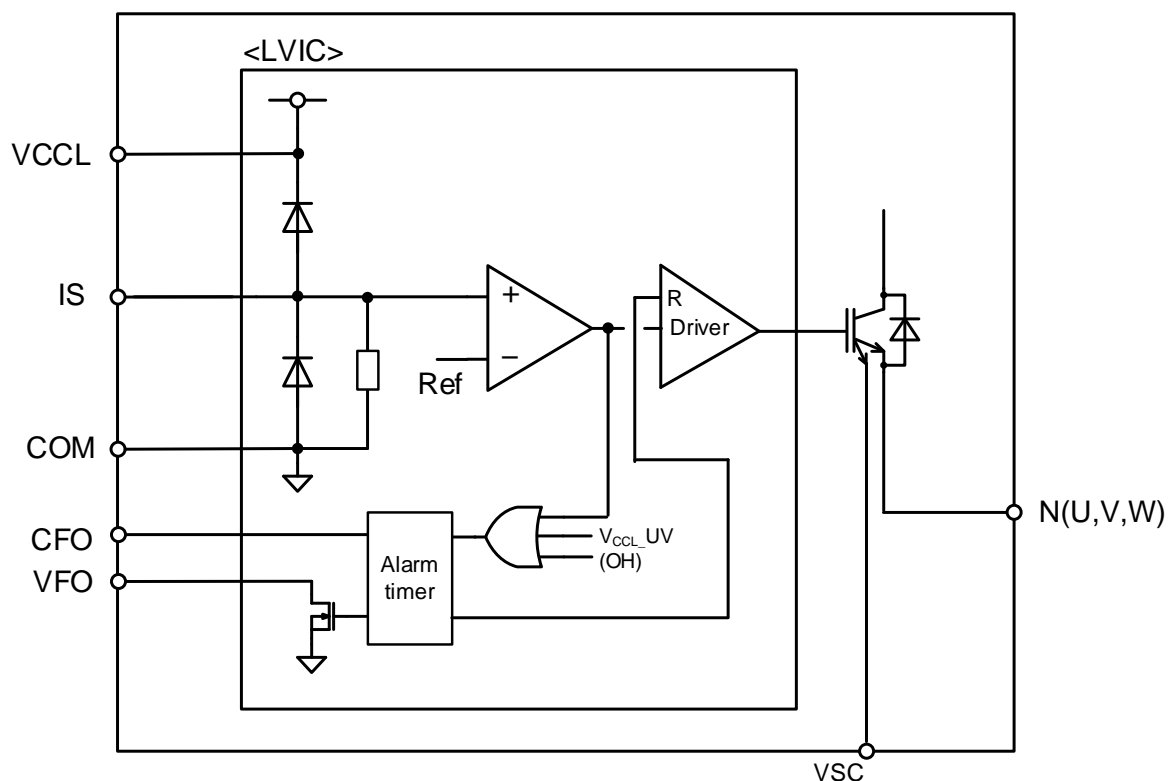

Fig. 3-19 OC protection detection circuit of IS terminal

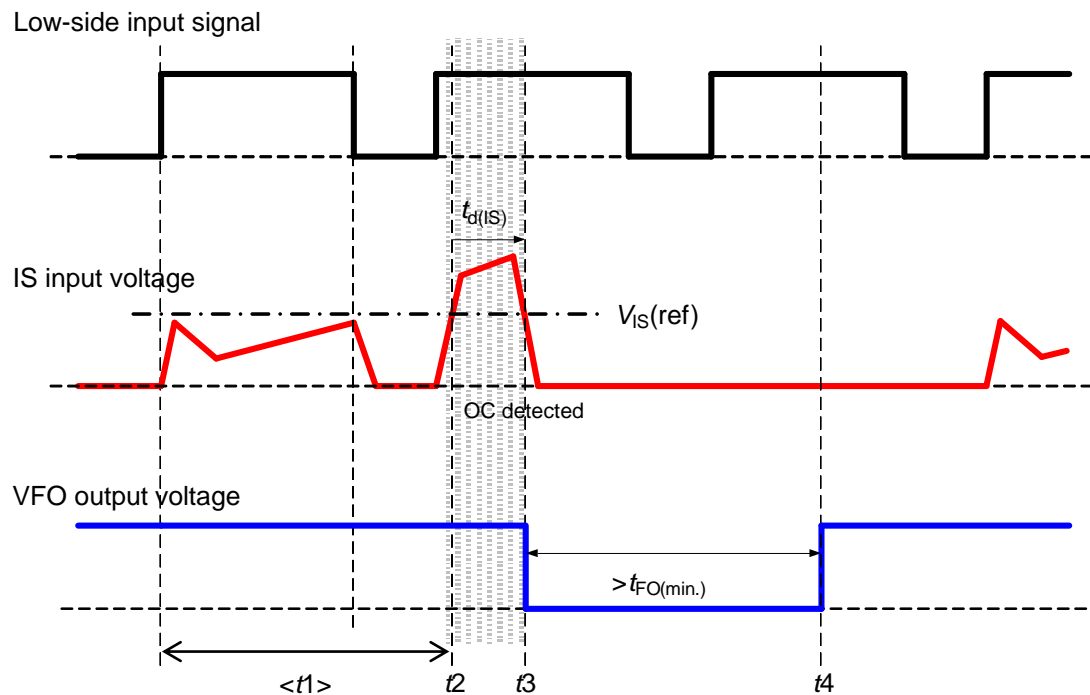

Fig. 3-20 OC protection operation sequence

- $<t_1>$  : The IS input voltage is less than  $V_{IS(ref)}$ . All low-side IGBTs perform normal switching operation.
- $t_2$  : When IS input voltage exceeds  $V_{IS(ref)}$ , OC is detected.
- $t_3$  : Fault output voltage is generated and all low-side IGBTs are turned off after the overcurrent protection delay time  $t_{d(IS)}$ . Propagation delay of LVIC is included in  $t_{d(IS)}$ .
- $t_4$  : OC protection is reset after  $t_{FO}$ . LVIC restarts switching operation from the next input signal.

## 6. Fault Status Output Function, VFO, CFO

As shown in Fig. 3-21, it is possible to connect the fault status output terminal VFO directly to the MPU. The VFO terminal is open drain configured, thus this terminal should be pulled up to 5V or 3.3V DC logic power supply with a resistor of about 10k $\Omega$ . It is also recommended to connect a bypass capacitor C1 and inrush current limiting resistor R1 of 5k $\Omega$  or more between the MPU and the VFO terminal. These signal lines should be as short as possible.

VFO terminal outputs fault status alarm during UV protection of  $V_{CC}$ , OC protection, and OH protection. (OH protection is built into "6MBP \*\* XTC065-50")

The pulse width of the fault status output ( $t_{FO}$ ) can be adjusted by the capacitance of the capacitor between CFO and COM terminal. The fault status output pulse width is 2.4ms when the capacitor capacitance is 22nF.  $C_{FO}$  is given by  $C_{FO} (\text{typ.}) = t_{FO} \times (9.1 \times 10^{-6}) (\text{F})$ .

As shown in Fig. 3-21, diodes are electrically connected between  $V_{CC}$ -VFO and VFO-COM terminals. These diodes are built-in to protect the IPM from input surge voltage. Do not use these diodes for voltage clamp purpose as it might damage the IPM.

Fig. 3-22 shows the voltage-current characteristics of VFO terminal during fault status output.  $I_{FO}$  is the sink current of VFO terminal.

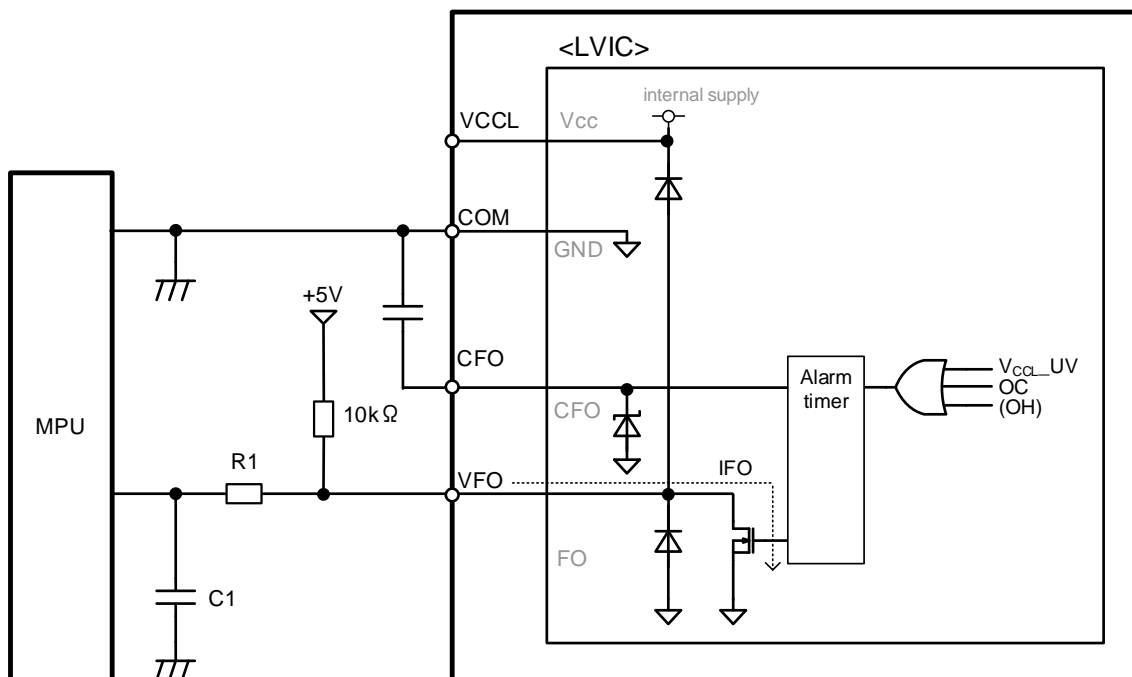

Fig. 3-21 Recommended MPU I/O interface circuit of VFO terminal

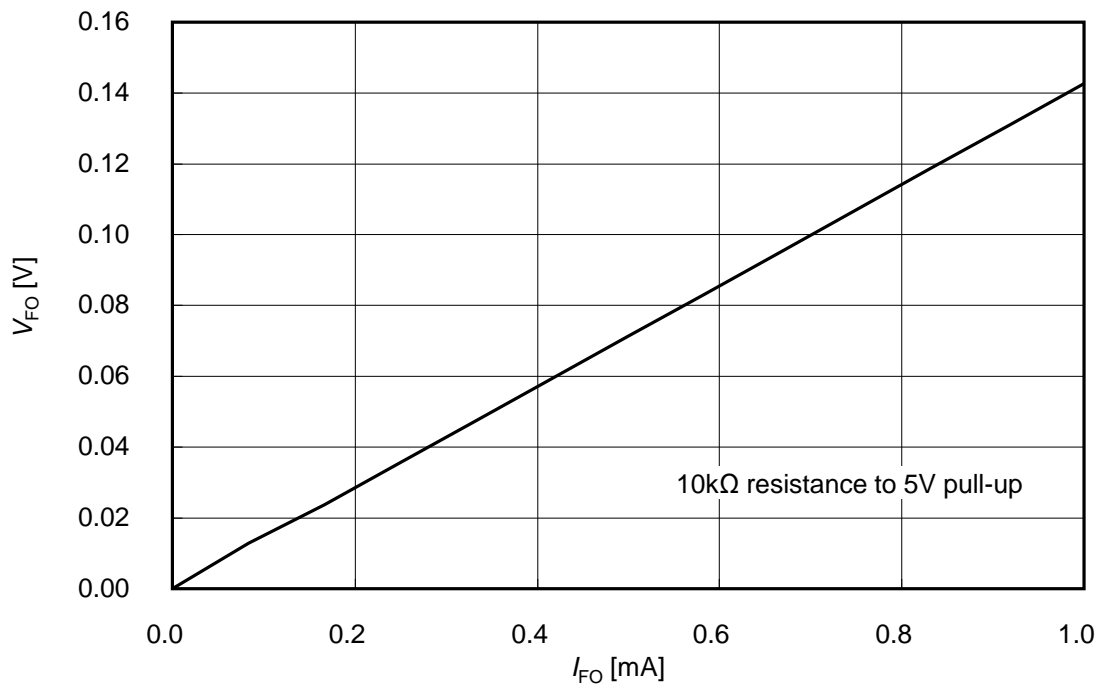

Fig. 3-22 Voltage-current characteristics of VFO terminal during fault status output



## 7. Temperature Output Function, TEMP

As shown in Fig. 3-23, the temperature output terminal TEMP can be connected directly to the MPU. It is recommended to connect a bypass capacitor and an inrush current limiting resistor of 10kΩ or more between the MPU and the TEMP terminal. These signal lines should be as short as possible.

This IPM has a built-in temperature sensor in LVIC that outputs analog voltage according to the LVIC virtual junction temperature. Since the position of the IGBT chip and the position of the temperature sensor are different, it is not possible to respond to sudden rise in  $T_{vj}$  such as during motor lock and short circuit. This function has no fault status output because it is not intended to protect the IPM.

"6MBP \*\* XTC065-50" has built-in overheating (OH) protection. Fault status output is generated when the temperature exceeds  $T_{OH}$ .

As shown in Fig. 3-23, a diode is electrically connected between the TEMP-COM terminals. This diode is built-in to protect the IPM from input surge voltage. Do not use this diode for voltage clamp purpose as it might damage the IPM.

Fig. 3-24 shows the LVIC virtual junction temperature versus TEMP output voltage characteristics. In the case of the MPU power supply voltage is 3.3V, connect a Zener diode to the TEMP terminal. The output voltage shows clamp characteristic at below room temperature. Connect a 5kΩ ± 10% pull-down resistor to the TEMP terminal if linear characteristic is required. Fig. 3-25 shows the LVIC virtual junction temperature versus TEMP output voltage characteristics with 5kΩ pull-down resistor.

Fig. 3-26 shows the operation sequence of the TEMP terminal during startup and shutdown of IPM.

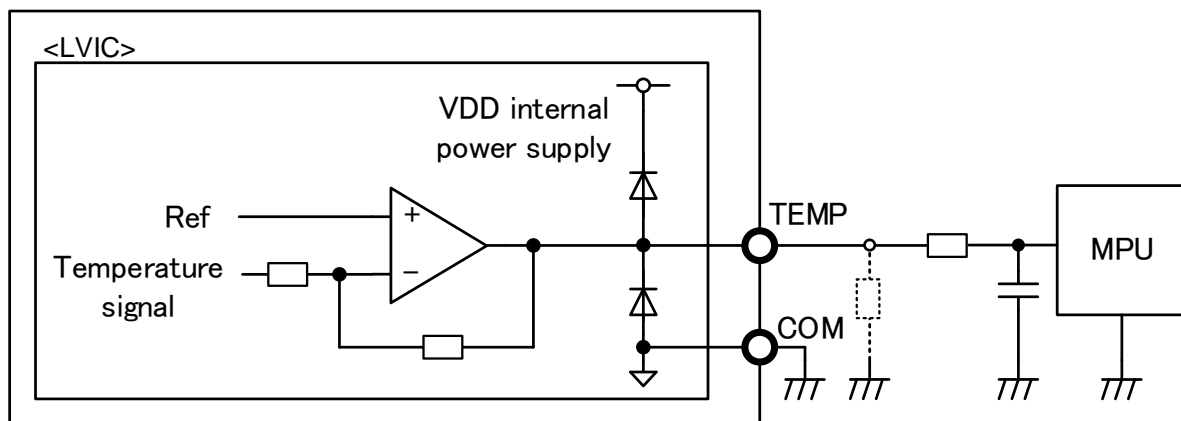

Fig. 3-23 Recommended MPU I/O interface circuit of TEMP terminal

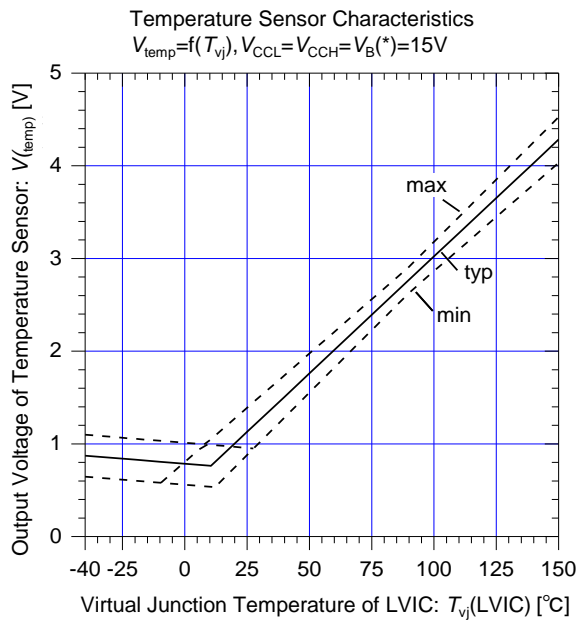

Fig. 3-24 LVIC virtual junction temperature vs. TEMP output voltage characteristic (without pull-down resistor)

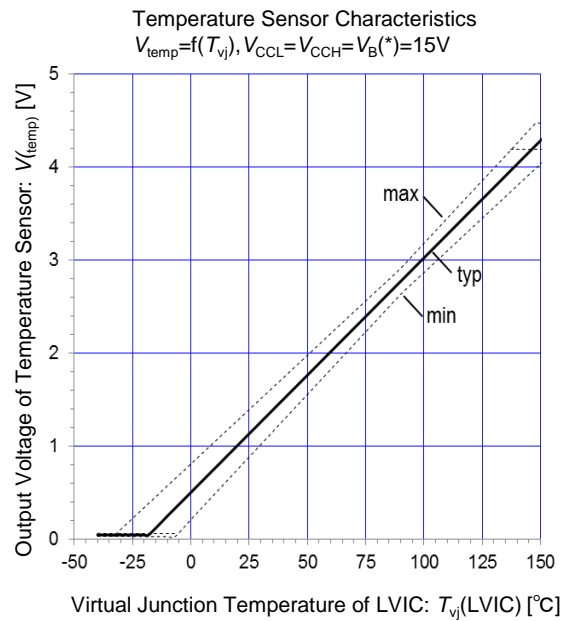

Fig. 3-25 LVIC virtual junction temperature vs. TEMP output voltage characteristic (with 5kΩ pull-down resistor)

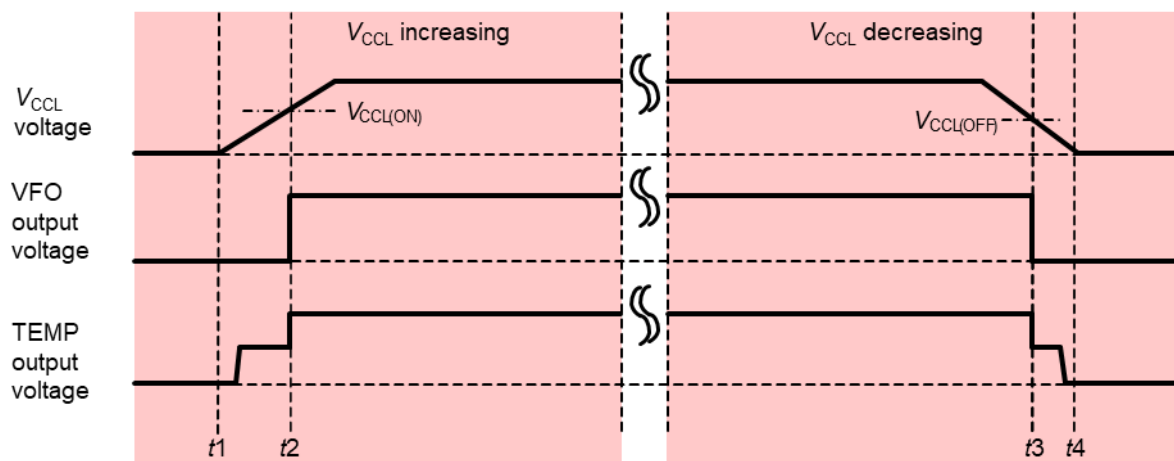

Fig. 3-26 Operation sequence of TEMP terminal during startup and shutdown of IPM

- $t1-t2$  : TEMP output function is activated when  $V_{CCL}$  exceeds  $V_{CCL(ON)}$ . When  $V_{CCL}$  is lower than  $V_{CCL(ON)}$ , TEMP output voltage is the same as clamp voltage.
- $t2-t3$  : TEMP output voltage rises to the voltage determined by LVIC virtual junction temperature. Under temperature condition that cause clamp operation, TEMP output voltage is the same as clamp voltage even if  $V_{CCL}$  exceeds  $V_{CCL(ON)}$ .
- $t3-t4$  : TEMP output function is reset when  $V_{CCL}$  falls below  $V_{CCL(OFF)}$ . TEMP output voltage is the same as clamp voltage.

## 8. Overheating Protection Function

The overheating (OH) protection function is built in “6MBP \*\* XTC065-50”.

The OH function monitors the LVIC virtual junction temperature.

Since the position of the IGBT chip and the position of the temperature sensor are different, it is not possible to respond to sudden rise in  $T_{vj}$  such as during motor lock and short circuit. Fig. 2-3 shows the position of the  $T_{OH}$  sensor.

As shown in Fig. 3-27, when LVIC virtual junction temperature exceeds  $T_{OH}$ , all low-side IGBTs are turned-off. If LVIC virtual junction temperature falls below  $T_{OH} - T_{OH(hys)}$ , OH function is reset.

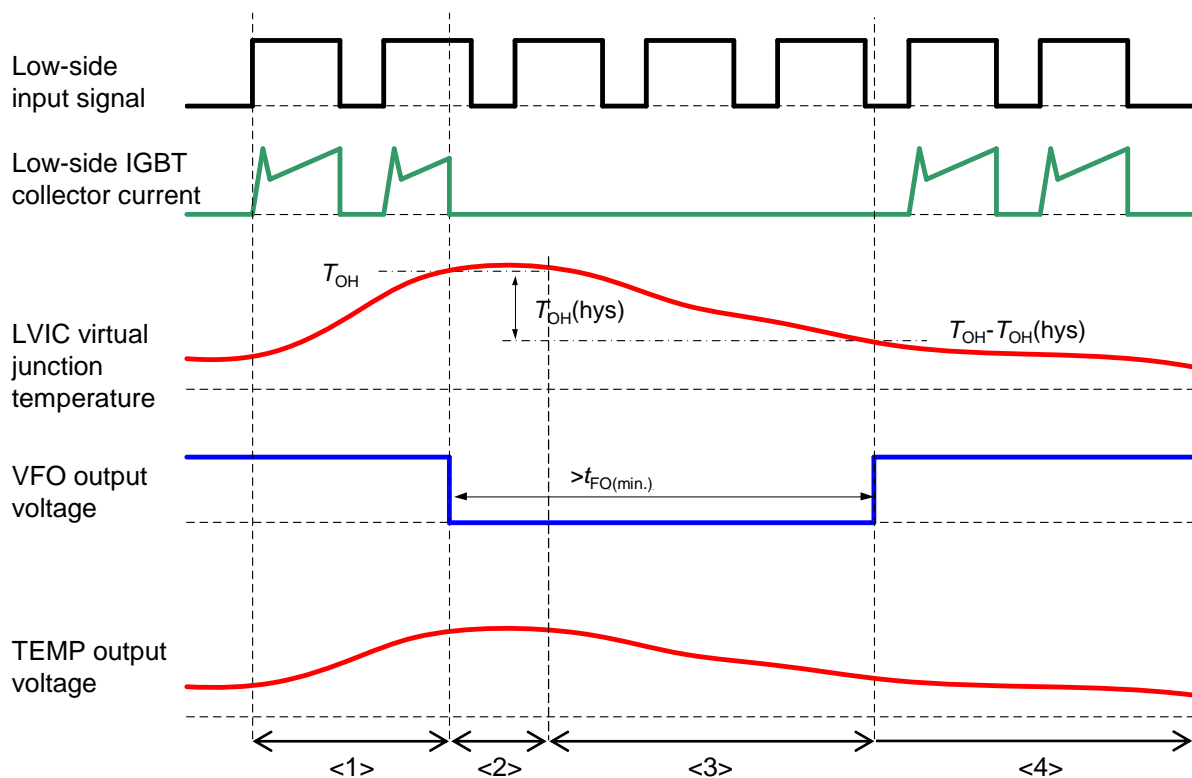

Fig. 3-27 OH protection operation sequence

- <1> : When LVIC virtual junction temperature is below  $T_{OH}$ , all low-side IGBTs operate normally.
- <2> : While LVIC virtual junction temperature is above  $T_{OH}$ , all low-side IGBTs are turned off.
- <3> : During OH protection status, TEMP terminal continues to output voltage corresponding to LVIC virtual junction temperature.
- <4> : Fault status and OH protection status are reset after LVIC virtual junction temperature falls below  $T_{OH} - T_{OH(hys)}$  and  $t_{FO}$  has elapsed. The low-side IGBTs restart operation from the next input signal.  $T_{OH(hys)}$  is the hysteresis temperature of overheating protection.

## Chapter 4 Details of Inverter Block

1. Connection of Bus Voltage Input Terminal and Low-side IGBTs Emitter	4-2
2. About Short Circuit Protection	4-4
3. Setting of External Shunt Resistor for Overcurrent Protection	4-6

## 1. Connection of Bus Voltage Input Terminal and Low-side IGBTs Emitter

This chapter describes the guidelines and precautions of circuit design for power terminals, such as how to determine the current sense resistor and external shunt resistor.

### 1. Description of Power Terminals

Table 4-1 shows the details of the power terminals.

Table 4-1 Details of power terminals

Terminal Name	Description
P	Bus voltage (+) input terminal. This terminal is connected to the collector of the high-side IGBTs internally. Connect a snubber capacitor close to this terminal to suppress the surge voltage generated by wiring inductance and the PCB pattern. (Generally, film capacitor is used)
U, V, W	Inverter output terminal. Connect to motor load.
N(U), N(V), N(W)	Bus voltage (-) input terminals. These terminals are connected to the emitter of the low-side IGBTs of each phase. When using the external shunt resistor method to monitor the current of each phase, connect a shunt resistor between these terminals and power GND.
VSC	Low-side sense current detection terminal. This terminal is connected to the sense terminal of the low-side IGBTs. This terminal detects the sense current shunted from the main current. Connect a sense resistor between VSC terminal and control GND for short-circuit protection.

## 2. Recommended wiring for shunt resistor and snubber capacitor

External shunt resistors are connected to detect overcurrent (OC) condition and phase current. Long wiring pattern between the shunt resistors and the IPM might generate excessive surge voltage that might damage the control IC and the OC detection components. The wiring between the shunt resistors and the IPM should be as short as possible.

As shown in Fig. 4-1, snubber capacitor should be connected at the right location to suppress surge voltage effectively. Generally, a snubber capacitor of 0.1 to 0.22 $\mu$ F is recommended. If the snubber capacitor is connected at point "A", the surge voltage cannot be suppressed effectively because the wiring inductance is not negligible.

If the snubber capacitor is connected at point "B", the charging and discharging current flowing through the snubber capacitor also flows through the shunt resistor. This will impact the current sensing signal, thus the OC protection level will be lower than the designed value. Although the surge voltage suppression effect when the snubber capacitor is connected at point "B" is better than at point "A" or point "C", in consideration of the current detection accuracy, point "C" is recommended.

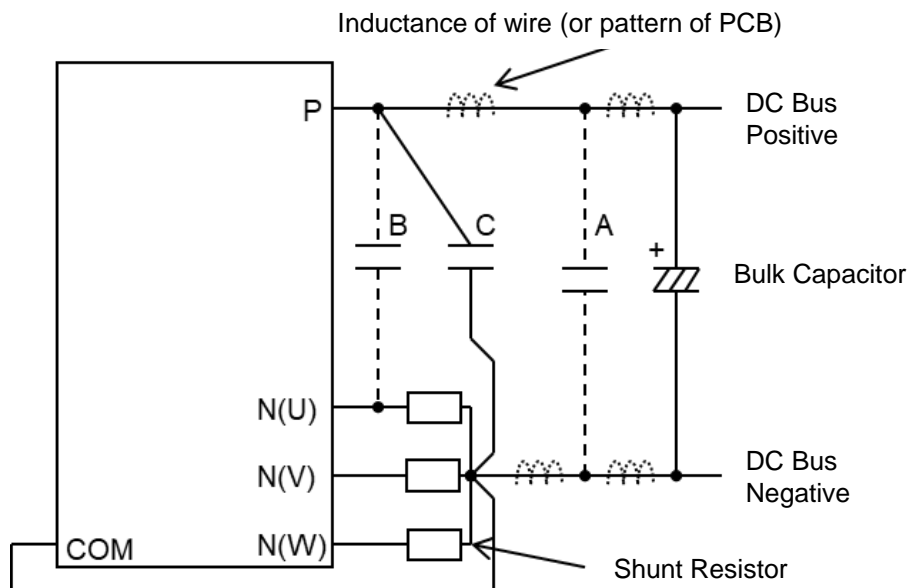
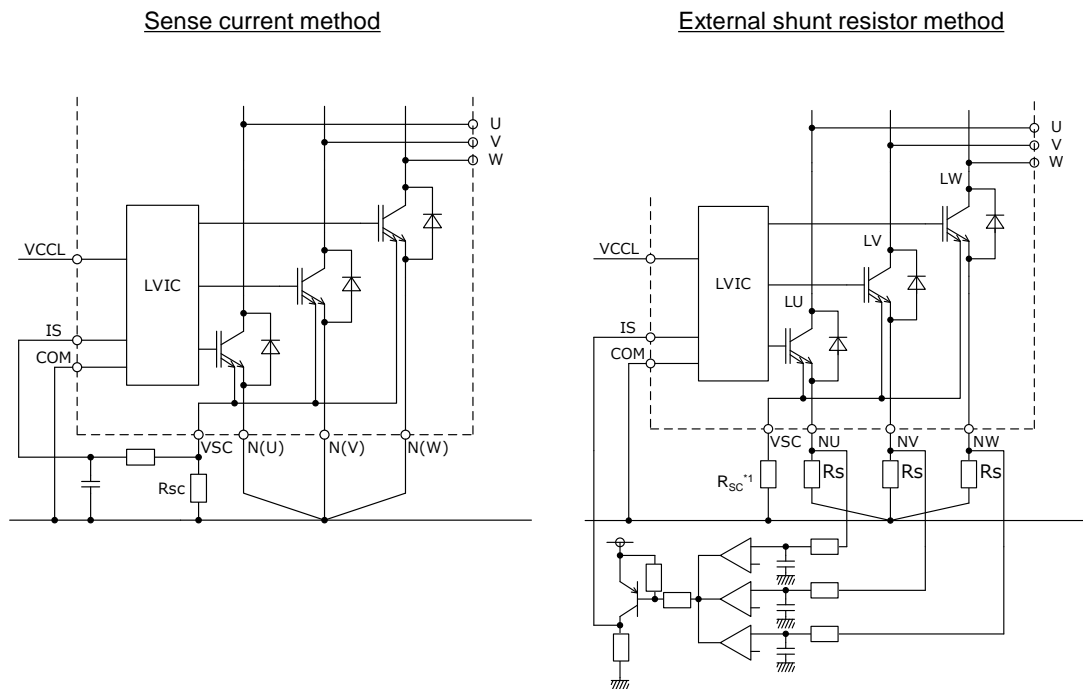

Fig. 4-1 Recommended wiring of shunt resistor and snubber capacitor

## 2. About Short Circuit Protection

There are two methods for short circuit (SC) protection in this IPM. The first method is by detecting the sense current shunted from the main current flowing through the low-side IGBTs. The second method is to directly sensing the main current with external shunt resistors connected to the N(\*) terminals.



\* When using the external shunt resistor method, connect the VSC terminal to the control GND with the specified sense resistor instead of leaving it open.

Fig. 4-2 SC detection circuits

### 1. SC protection by sense current method

SC protection works by feeding back the voltage generated by the sense resistor  $R_{sc}$  to the IS terminal. Table 4-2 shows the specified sense resistor value and short circuit protection current value.

Table. 4-2 SC protection current value (no external shunt resistor connected to N(\*) terminals)

Type Name	Sense resistor $R_{sc}$	SC protection current (Min.)
6MBP50XTA065-50 6MBP50XTC065-50	40.2 $\Omega$	85 A
6MBP75XTA065-50 6MBP75XTC065-50	23.2 $\Omega$	127 A

It is recommended to connect an RC filter to the input of IS terminal to prevent malfunction of the SC protection circuit caused by noise. The RC time constant is determined by the noise application time and the IGBT's short circuit capability. Time constant of 1.1 $\mu$ s is recommended.

To activate 6MBP50XTA065-50 SC protection,  $R_{sc}$  must be set to 40.2 $\Omega$  or higher.

For  $R_{sc}$ , it is recommended to use a resistor with small variation (1% or less) including temperature characteristics, low inductance, and wattage rating of 1/8W or more.

## **2. SC protection by external shunt resistor method**

The SC protection function by sense current method is intended for short circuit protection when an excessive short circuit current flows, such as arm short circuit or load short circuit.

For OC protection that requires accuracy, such as demagnetization current protection of motor, external shunt resistor method is recommended.

When external shunt resistor is connected, the current split ratio between the main and sense current varies, thus the SC protection current value by sense resistor changes too. Table 4-3 shows the minimum SC protection value with shunt resistors connected.

If the external shunt resistance is too large, the IGBT saturation current will decrease due to the gate voltage of the low-side IGBT is lowered by the shunt resistor voltage drop. It is recommended to set the shunt resistance to 7m $\Omega$  or less for 6MBP50XT\*065-50, and 4.5m $\Omega$  or less for 6MBP75XT\*065-50.

When using external shunt resistors, it is recommended to use low inductance chip resistors to reduce the surge voltage during short circuit. Do not use shunt resistors with large inductance, such as cement resistors.

Table 4-3 SC protection current value with shunt resistors (6MBP50XT\*065-50,  $R_{sc}=40.2\Omega$ )

External shunt resistance	OC protection current (Min.)
None	85 A
3 m $\Omega$	57 A
5 m $\Omega$	48 A

When using the external shunt resistor method, connect the VSC terminal to the control GND with the specified sense resistor instead of leaving it open.



### 3. Setting of External Shunt Resistor for Overcurrent Protection

The following shows an example of selecting external shunt resistor for OC, SC protection, in which OC, SC detection is performed using only external shunt resistor instead of the current sensing method.

When using the external shunt resistor method, connect the VSC terminal to the control GND with the specified sense resistor instead of leaving it open.

#### **1. Selecting shunt resistor**

The shunt resistance value is calculated by the following equation :

$$R_{Sh} = \frac{V_{IS(ref)}}{I_{OC}} \quad (4.1)$$

where  $V_{IS(ref)}$  is the OC protection voltage level of IPM, and  $I_{OC}$  is the OC protection current level.  $V_{IS(ref)}$  is 0.455V(min.), 0.48V(typ.), and 0.505V(max.).  $R_{sh}$  is the resistance of shunt resistor. The maximum OC detection level should be set lower than the repetitive peak collector current specified in the specification sheet of the IPM considering the variations in shunt resistance.

For example, if the OC detection level is set to 100A, the recommended shunt resistance value can be calculated as:

$$R_{Sh(min)} = \frac{V_{IS(ref)(max)}}{I_{OC}} = \frac{0.505}{100} = 5.05[m\Omega] \quad (4.2)$$

where  $R_{sh(min)}$  is the minimum shunt resistance.

Based on the above expressions, the minimum shunt resistance is calculated. It is necessary to select a shunt resistance according to the required OC protection level in practical application.

where  $R_{sh(min)}$  is the minimum shunt resistance.

Based on the above expressions, the minimum shunt resistance is calculated. It is necessary to select a shunt resistance according to the required OC protection level in practical application.

## 2. Setting the delay time of OC protection

An external RC filter is required to prevent malfunction of the OC protection circuit caused by noise. The RC time constant is determined by the noise application time and the IGBT's short circuit capability. Time constant of 1.1μs is recommended.

When the voltage across the shunt resistor exceeds the OC level, the filter delay time  $t_{delay}$ , which is the time for the IS terminal input voltage to rise to the OC level, is determined by the time constant of the RC filter and is expressed by the following equation.

$$t_{(delay)} = -\tau \cdot \ln\left(1 - \frac{V_{IS(ref)(max)}}{R_{Sh} \cdot I_P}\right) \quad (4.3)$$

where  $\tau$  is the RC time constant, and  $I_P$  is the peak current flowing through the shunt resistor.

In addition, there is a shutdown propagation delay of OC ( $t_{d(IS)}$ ), thus the total time  $t_{total}$  from OC detection until the shutdown of IGBT is given by the following equation.

$$t_{total} = t_{delay} + t_{d(IS)} \quad (4.4)$$

The short circuit capability of the IGBT must be considered for the total delay time. Please confirm the appropriate delay time in actual equipment.

## Chapter 5 Recommended Wiring and Layout

1. Examples of Application Circuit	5-2
2. Recommendations and Precautions in PCB Design	5-6

## 1. Examples of Application Circuit

This chapter describes the recommended wiring and layout.

Please refer to the following application circuit examples for tips and precautions when designing PCB.

Fig. 5-1, Fig. 5-2, and Fig. 5-3 show examples of application circuits using three types of current detection methods. The notes are common for all circuits.

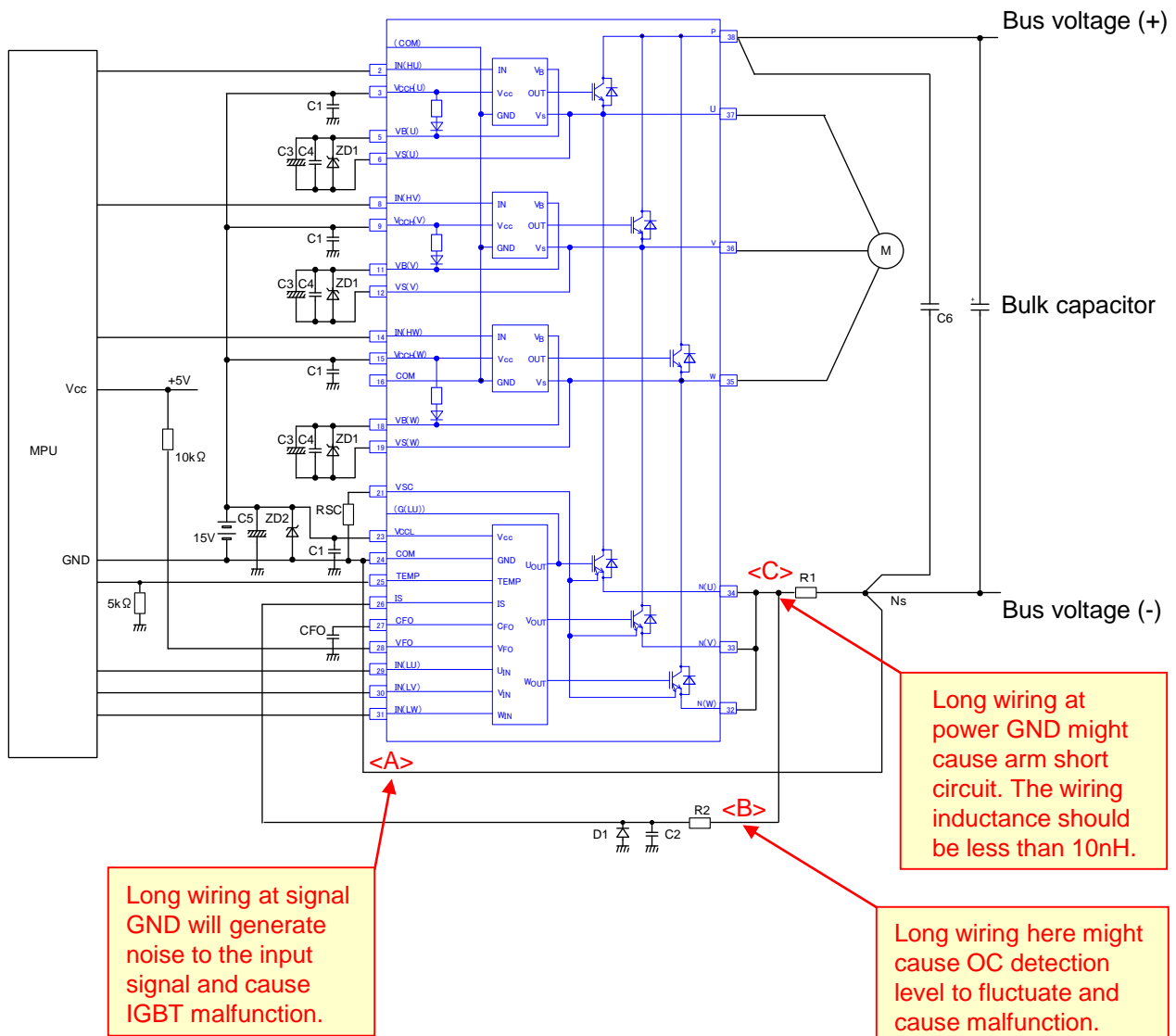

Fig. 5-1 Example of application circuit 1

(In the case of detecting all 3 phase current at once with a single shunt resistor)

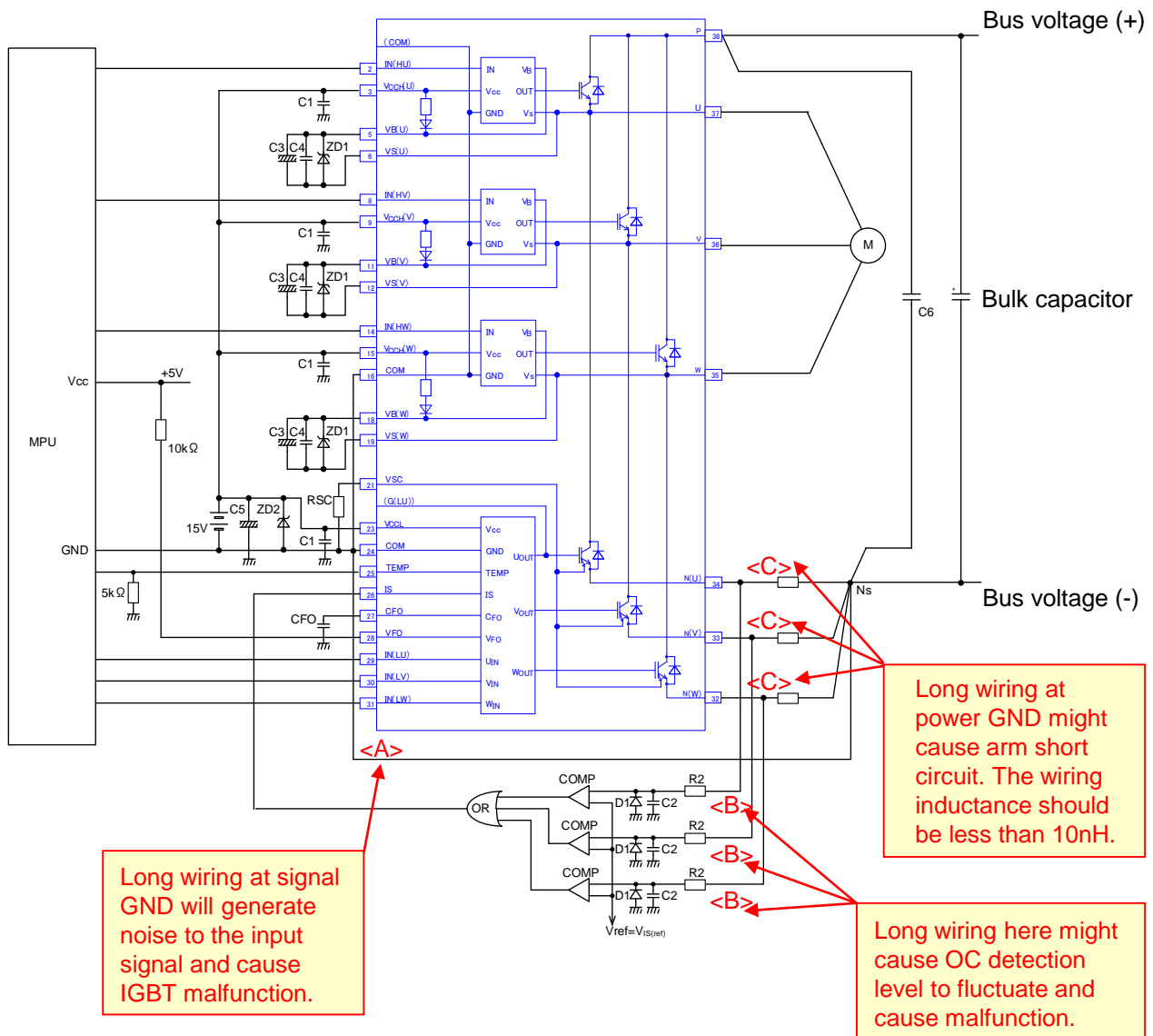

Fig. 5-2 Example of application circuit 2

(In the case of detecting each phase current with individual shunt resistor )

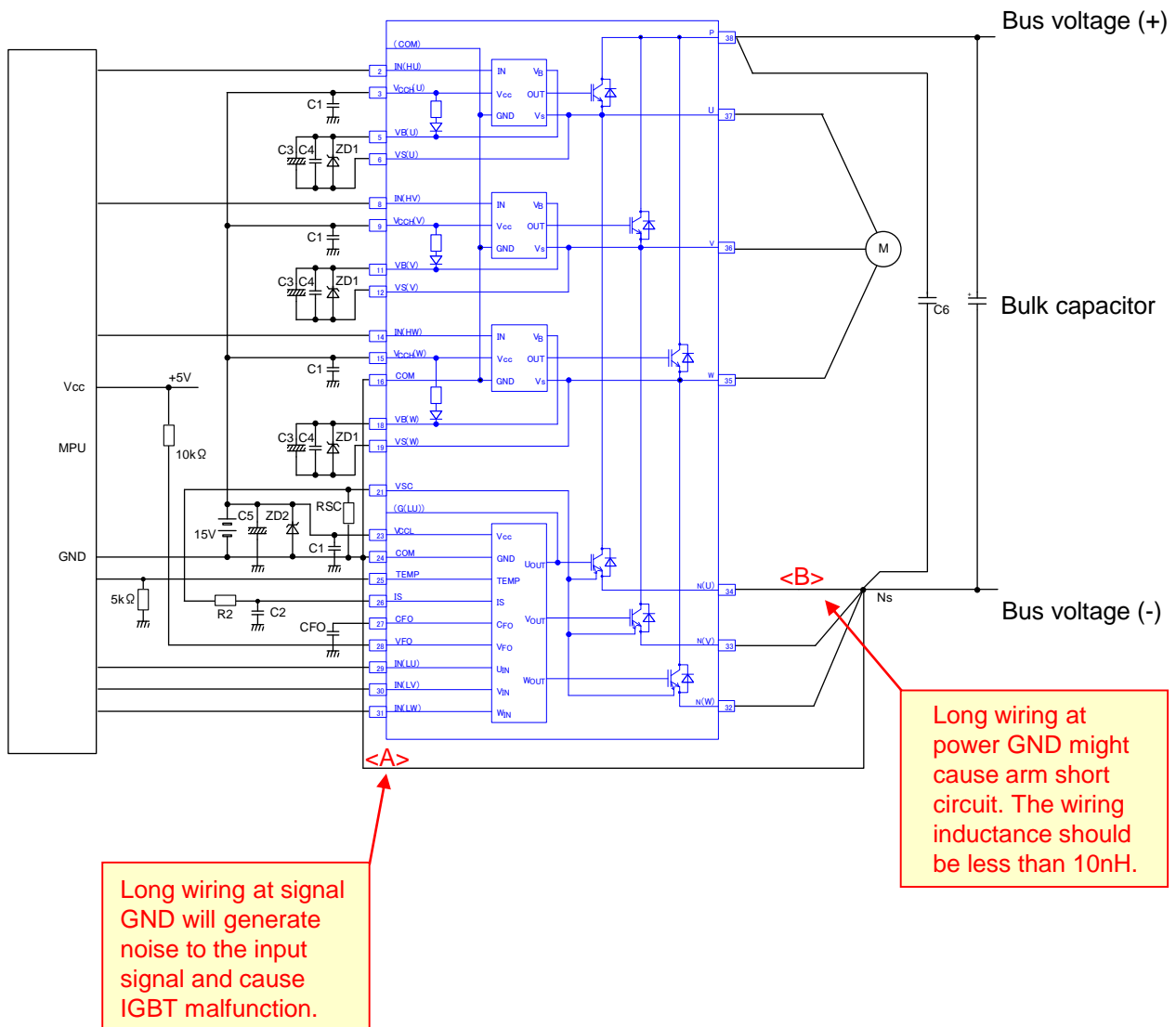

Fig. 5-3 Example of application circuit 3

(In the case of detecting sense current with sense resistor )

<Note>

1. The input signal of this product is high active. The input circuit of the control IC has built-in pull-down resistors. To prevent malfunction, the wiring of each input should be as short as possible. When using RC filter, set the input signal level to meet the turn-on and turn-off threshold voltages.
2. VFO output is open drain type. It should be pulled up to 5V power supply with resistor of about 10k $\Omega$ .
3. To prevent malfunction, the wiring of <A>, <B> and <C> should be as short as possible.
4. Set the time constant of R2-C2 of the OC protection circuit to about 1.1 $\mu$ s. The OC shutdown time might vary depending on the wiring pattern. For R2 and C2, tight tolerance, temperature compensated type is recommended.
5. It is recommended to set the OC protection circuit comparator reference voltage to the same level as the IPM OC protection threshold voltage  $V_{IS(ref)}$ .
6. Use high speed comparator and logic IC to detect OC condition quickly.
7. It is recommended to connect a Schottky barrier diode D1 if negative voltage is generated at R1 during switching operation.
8. All capacitors should be connected as close as possible to the terminals. Ceramic capacitors with excellent temperature, frequency and DC bias characteristics for C1 and C4, and electrolytic capacitors with excellent temperature and frequency characteristics for C3 and C5 are recommended.
9. To prevent destruction caused by surge voltage, the wiring between snubber capacitor C6, P terminal and Ns node should be as short as possible. Generally, the recommended snubber capacitance is 0.1 $\mu$ F to 0.22 $\mu$ F.
10. The two COM terminals (terminal no.16 & 24) are not connected internally. Connect both terminals to the signal GND at single point.
11. To prevent the destruction caused by surge voltage, it is recommended to connect a 22V Zener diode to each control power supply and high-side bias voltage terminal.
12. It is recommended that the signal GND and the power GND be wired separately, and to connect the snubber capacitor GND : Ns at a single point to avoid the effect of voltage fluctuation due to current flowing in the power line.
13. For  $R_{sc}$ , it is recommended to use a resistor with small variation (1% or less) including temperature characteristics, low inductance, and wattage rating of 1/8W or more. Please evaluate it sufficiently in actual system.
14. When using external shunt resistors, it is recommended to use low inductance chip resistors. Do not use shunt resistors with large inductance, such as cement resistors.

## 2. Recommendations and Precautions in PCB Design

In this section, the recommended pattern layout and precautions in PCB design are described. Fig. 5-4 to Fig. 5-8 show the images of recommended PCB layout in examples of application circuit (Fig. 5-1, Fig. 5-2, Fig. 5-3). In these figures, the input signal from the system is represented by “IN(HU)”.

Recommended layouts and precautions are as follows.

### (1) Overall design around the IPM

- (A) At boundary where the potential difference is high, secure an appropriate creepage distance. (Make a slit in PWB if necessary)
- (B) Separate the pattern of power input (DC bus voltage) part and the high-side bias voltage part to prevent the increase of conduction noise. In the case of using a multilayer PCB and crossing these wirings on pattern, please take note of the stray capacitance between the wirings and the insulation performance of the PCB.
- (C) Separate the high-side bias voltage and the input circuit pattern for each phase to prevent system malfunction. In the case of using a multilayer PCB, it is strongly recommended not to cross these wirings.

Details of each part are described in next page.

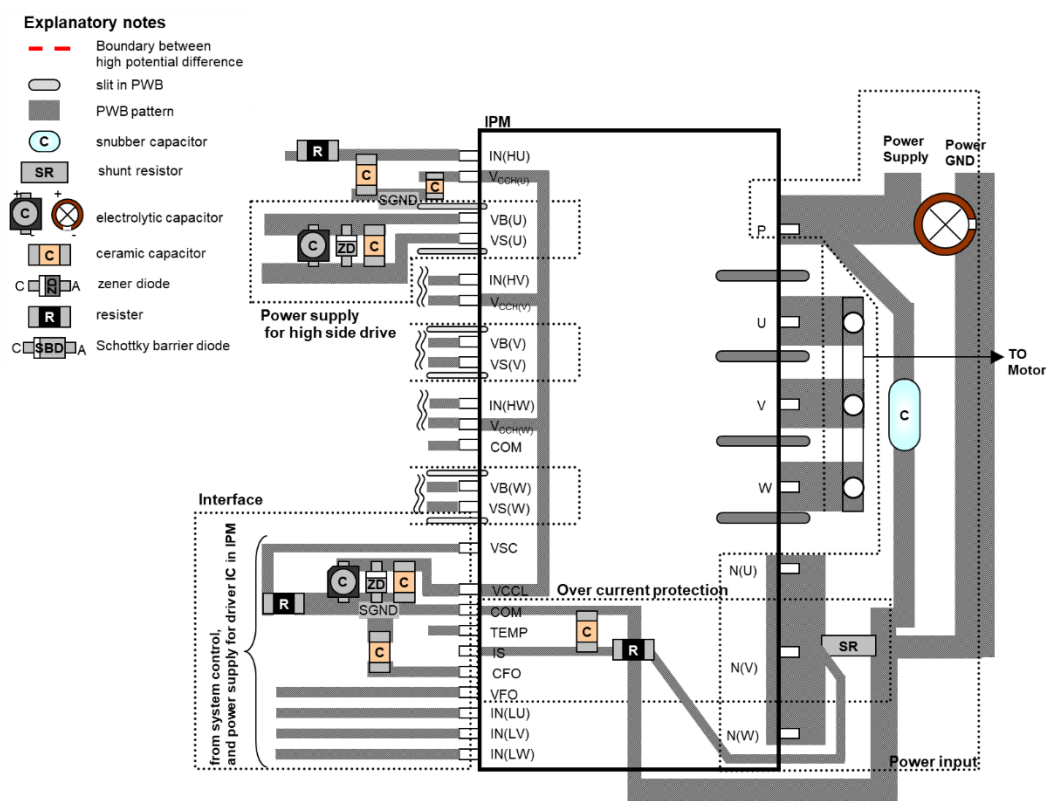

Fig. 5-4 Image of recommended PCB layout (Overall design around the IPM)



(2) Power input part

- (A) Connect the snubber capacitor between the P terminal and the GND of the shunt resistor as close as possible. To avoid the influence of pattern inductance, the pattern between snubber capacitor, P terminal and shunt resistor should be as short as possible.
- (B) Separate the pattern of the bulk capacitor and the pattern of the snubber capacitor near to the P terminal and shunt resistor.
- (C) The pattern from the power GND and COM terminal should be connected as close as possible to the shunt resistor at a single point ground.
- (D) Please use low inductance type for shunt resistor.
- (E) The pattern between the N(U), N(V), N(W) terminals and the shunt resistor should be as short as possible.

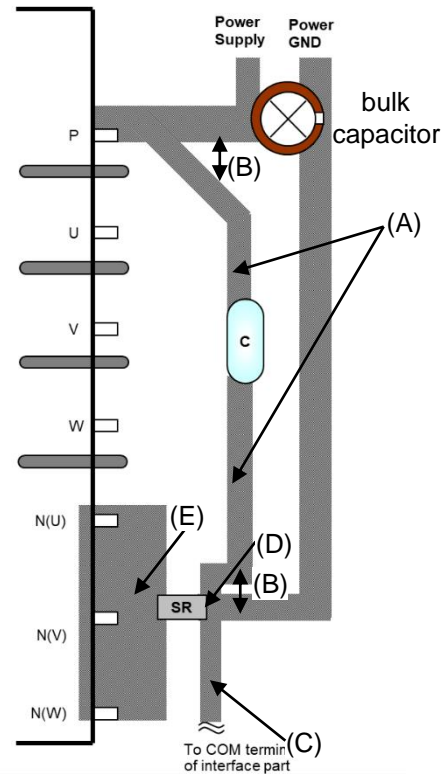

Fig. 5-5 Image of recommended PCB layout  
(Power input part)

(3) High-side bias voltage part

- (A) The pattern between VB(U,V,W) terminal and the electronic components (ceramic capacitor, electrolytic capacitor, Zener diode) should be as short as possible.
- (B) Use an appropriate capacitor according to the application. In particular, use a ceramic capacitor or a low ESR capacitor close to the VB(U,V,W) terminals.
- (C) If the stray capacitance between VB(U) and the power GND (or equal potential) terminal is large, the voltage between VB(U) and VS(U) terminals might become overvoltage or negative voltage due to the high  $dV/dt$  during IGBT turn-on and turn-off. Therefore, it is recommended to connect a Zener diode between VB(U) and VS(U) terminals. It should be connected as close as possible to VB (U) terminal.  
(The same applies to VB(V) and VB(W).)

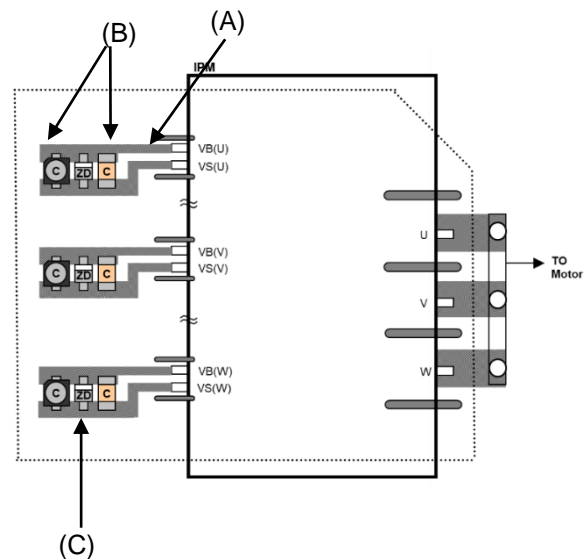
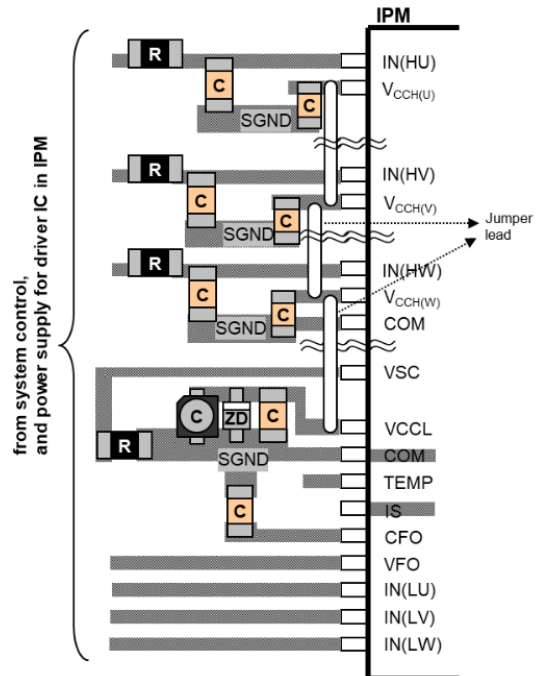

Fig. 5-6 Image of recommended PCB layout  
(High-side bias voltage part)

(4) Interface part

- (A) If the influence of noise from the high-side bias voltage is not negligible, connect a capacitor between the input signal and the COM terminal. The negative pole of the capacitor should be connected to the signal GND as close as possible to the COM terminal. In the case of connecting a filter resistor or capacitor, please take into account of the built-in pull-down resistor and confirm the the input signal level in the actual system.
- (B) The two COM terminals (terminal no.16 & 24) are not connected internally. Connect both terminals to the signal GND at single point.
- (C) Connect an electrolytic capacitor and a ceramic capacitor between VCCL and COM, and between VCCH(U,V,W) and COM. Connect these capacitors as close as possible to each terminal.
- (D) The output signal from the TEMP terminal should be in parallel with the signal GND in order to minimize the effect of noise.
- (E) The pattern of signal GND from the system and the pattern from the COM terminal should be connected at a single point ground. The single point ground should be as close as possible to the COM terminal.



Note) The input signal is represented with "IN(HU)".

Fig. 5-7 Image of recommended PCB layout (Interface part)

(5) Overcurrent protection part

As shown in Fig. 5-1, Fig. 5-2 and Fig. 5-3, there are three methods for OC detection and protection. They are “Detecting all 3 phase current at once with a single shunt resistor method” (Fig. 5-8(a)), “Detecting each phase current with individual shunt resistor method” (Fig. 5-8(b)), and “Detecting sense current with sense resistor method” (Fig. 5-8(c)).

In Fig. 5-8(a)

- (A) The pattern between the negative pole of the shunt resistor and the COM terminal is very important. It is the reference potential for the control IC, and also the path for the high-side bootstrap capacitor charging current and the low-side IGBT gate drive current. Therefore, to minimize the effect of common impedance, this pattern should be as short as possible.
- (B) The pattern of IS signal should be as short as possible to avoid OC level fluctuation.
- (C) To prevent erroneous detection during switching operation, connect a RC filter to the IS terminal. The negative pole of the RC filter capacitor should be connected to the signal GND near the COM terminal.
- (D) If negative voltage is applied to the IS terminal during switching operation, connect a Schottky barrier diode between the IS terminal and the COM terminal or in parallel with the shunt resistor.

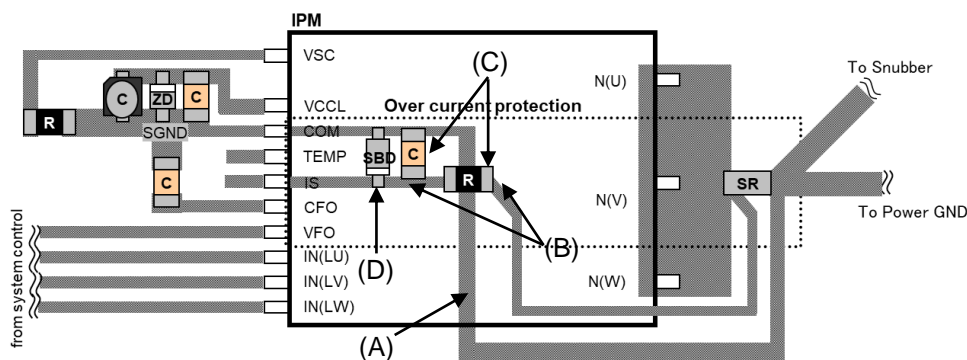

Fig. 5-8(a) Detecting all 3 phase current at once with a single shunt resistor method

In Fig. 5-8(b)

- (A) Use high speed comparator and logic IC to detect OC condition quickly
- (B) The reference voltage of OC which is input to the comparator should be coupled by a capacitor to signal GND. The capacitor should be connected as close as possible to the comparator.
- (C) Separate the signal GND pattern of COM terminal and the signal GND pattern of comparator.
- (D) The signal GND pattern of COM terminal and the signal GND pattern of comparator should be connected at a single point ground. The single point ground should be as close as possible to the shunt resistor.
- (E) Other precautions and recommended patterns are same as Fig. 5-7(a). Refer to Chapter 4, Section 2 for details on circuit constant determination.

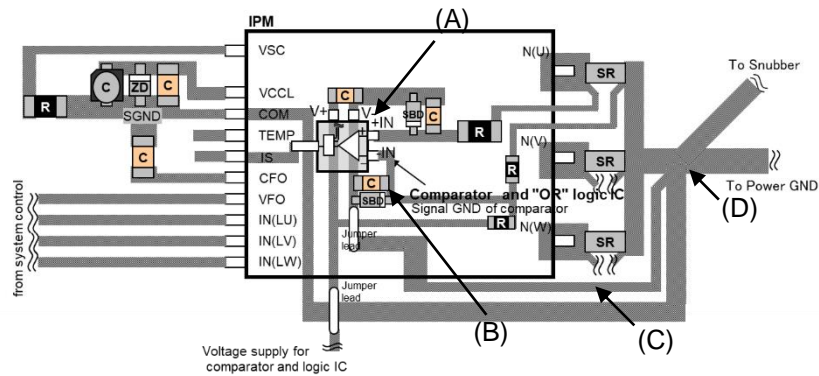

Fig. 5-8(b) Detecting each phase current with individual shunt resistor method

In Fig. 5-8(c)

- (A) It is recommended that the signal GND and the power GND be wired separately, and to connect the snubber capacitor GND : Ns at a single point to avoid the effect of voltage fluctuation due to current flowing in the power line.
- (B) To prevent fluctuations of the OC protection level and malfunction, the IS signal pattern should be as short as possible.
- (C) To prevent erroneous detection during switching operation, connect a RC filter to the IS terminal. The negative pole of the RC filter capacitor should be connected to the signal GND near the COM terminal.

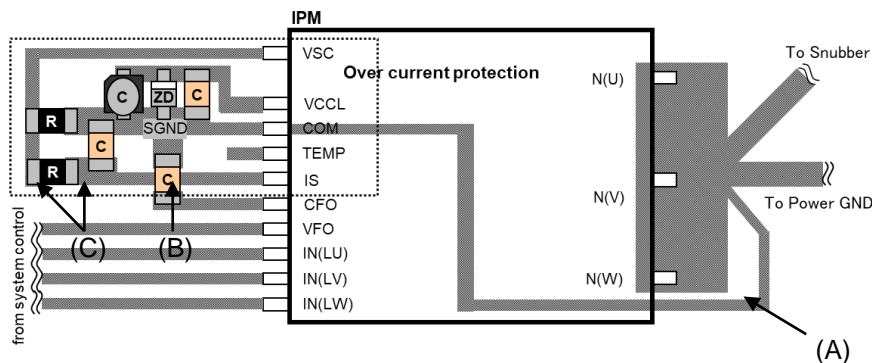

Fig. 5-8(c) Detecting sense current with sense resistor method

## Chapter 6 Mounting Guidelines and Thermal Design

1. Soldering to PCB	6-2
2. Mounting to Heat Sink	6-3
3. Spacer Position	6-4
4. Cooler (Heat Sink) Selection	6-5

## 1. Soldering to PCB

### Soldering

- (1) The IPM temperature during soldering might exceed the absolute maximum rating of the IPM. To prevent damage to the IPM and to ensure reliability, please do not use exceed the following soldering temperature.

Table 6-1 Soldering temperature and immersion time

Method	Soldering temperature and time
Dip soldering	260±5°C, 10±1sec

- (2) A stopper is provided on the terminal to prevent the immersion depth of the terminal from coming too close to the product body. Use this stopper to secure the required distance from the printed circuit board and prevent the product body from being immersed in the solder bath during flow soldering.
- (3) It is not recommended to reuse the product after it is removed from the printed circuit board because there is a possibility that the removed product was subjected to thermal or mechanical damage during the removal process.

## 2. Mounting to Heat Sink

### Mounting procedure and precautions

When mounting the IPM to a heat sink, please refer to the following recommended tightening sequence. Uneven tightening due to excessive torque might lead to destruction or degradation of the chip.

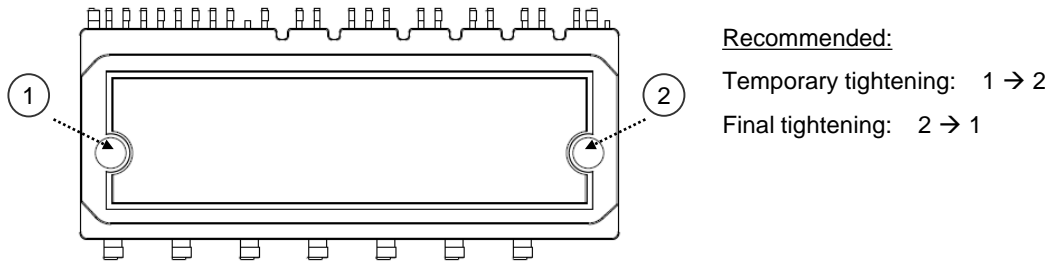

Note) Set the temporary tightening torque to about 30% of the maximum torque rating

Fig. 6-1 Recommended screw tightening sequence

Fig. 6-2 shows the measurement position of the heat sink flatness.

The flatness of the heat sink should be  $0\mu\text{m}/100\text{mm}$  to  $+100\mu\text{m}/100\text{mm}$ , and the surface roughness (Rz) should be less than  $10\mu\text{m}$ .

If the heat sink has a concave surface, a gap occurs between the heat sink and the IPM, leading to reduced cooling efficiency.

If the flatness is  $+100\mu\text{m}$  or more, the aluminum base of the IPM may be deformed and cracks could occur in the internal insulating substrate.

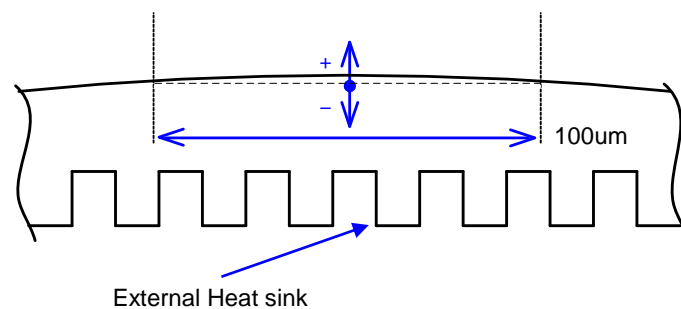

Fig. 6-2 The measurement position of heat sink flatness

It is recommended to apply thermal grease using a stencil mask to obtain the heat dissipation effect. The stencil mask is described in the mounting instructions (MT6M16534).

### 3. Spacer Position

When fixing the IPM using a resin spacer or metal spacer between the PCB and the IPM, such as during soldering, it is recommended to support the IPM at the shaded area as shown in Fig. 6-3.

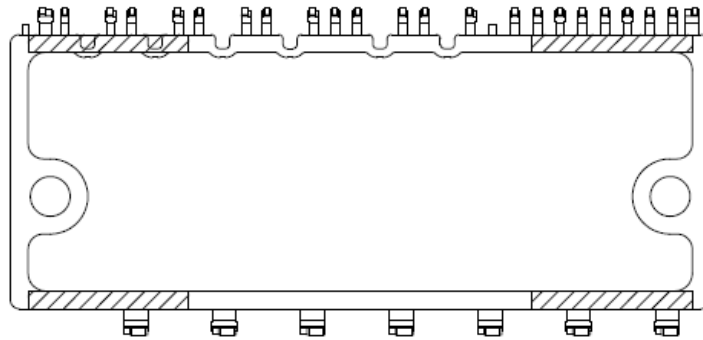

Fig. 6-3 Recommended spacer position



## 4. Cooler (Heat Sink) Selection

- Please design the cooling body (heat sink) so that the IGBT virtual junction temperature does not exceed the maximum virtual junction temperature  $T_{vj}$  for safe operation even during abnormal conditions such as overload.
- Operation of the IGBT at a temperature higher than the maximum virtual junction temperature  $T_{vj}$  might cause damage to the chip. In IPM, when the IGBT chip temperature exceeds  $T_{vj}$ , the overheating protection function operates. However if the temperature rises rapidly, the chip might not be protected.
- Similarly, please make sure that the FWD chip temperature does not exceed the  $T_{vj}$  too.
- When selecting a cooling body (heat sink), please verify the chip temperature by measuring at the position shown in Figure 2-3.

Please refer to Chapter 6, Section 2 and the following document for more details about thermal design:  
“FUJI IGBT MODULES APPLICATION MANUAL (REH984e)”

Contents:

- Power dissipation loss calculation
- Selecting heat sinks
- Heat sink mounting precautions
- Troubleshooting

## Chapter 7 Notes

1. Precautions for Use	7-2
2. Precautions for Handling and Storage	7-3
3. Notice	7-4

## 1. Precautions for Use

- Use this IPM within the absolute maximum ratings (voltage, current, temperature, etc.). This IPM might be destroyed if used beyond the absolute maximum ratings.
- Please refer to this application manual for detailed information on usage, PCB layout, mounting instruction, etc.
- The equipment containing IPM should have adequate fuses or circuit breakers to prevent the equipment from causing secondary destruction (ex. fire, explosion etc.)
- Check that the turn-off voltage and current are within the RBSOA specifications.
- When designing, consider the rise in package temperature, virtual junction temperature, and lead terminal temperature, and confirm that they are within the absolute maximum ratings.
- This IPM is made from incombustible material. However, if the IPM breaks down, it may emit smoke or fire. The IPM may become hot during operation. Thus when operating in places with flammable or combustible materials, or in places where heat is generated, smoke or fire may occur. Please take measures to prevent the spread of fire.
- Do not touch the product terminals or package directly during operation or while power is being supplied in order to avoid electric shock or burns.
- Connect an appropriate ceramic capacitor close to VCCH(U) and COM, VCCH(V) and COM, VCCH(W) and COM, and VCCL and COM terminals so that high frequency noise such as switching noise is not directly applied to VCCH(U), VCCH(V), VCCH(W) and VCCL terminals.
- If noise is applied to the control terminal, the IPM may malfunction. Please make sure that unstable operation or malfunction due to noise does not occur.
- If  $V_{B(U)}$ ,  $V_{B(V)}$  or  $V_{B(W)}$  falls below  $V_{B(off)}$  due to noise, etc., the corresponding high-side IGBT may turn-off. Connect an appropriate ceramic capacitor between VB(U) and VS(U), VB(V) and VS(V), VB(W) and VS(W) terminals.
- The input signal voltage must exceed the threshold voltage.
- If excessive static electricity is applied to the control terminals, the IPM may be damaged. Implement some countermeasures against static electricity.
- When handling the IPM, hold it by the case (package body) without touching the lead terminals.
- We recommend that you handle the IPM on a grounded conductive floor and table mat.
- Before touching the IPM terminals, discharge static electricity from your body and clothes by grounding through a high resistance of about 1MΩ.
- When soldering, ground the soldering iron or solder bath to prevent the leakage voltage being applied to the product.
- Do not apply mechanical stress that may deform the terminals.
- Use this IPM within its reliability and lifetime. If used beyond the reliability lifetime, the IPM may be destroyed before the target lifetime of the equipment.
- Please check electrical characteristic, thermal characteristic, and mechanical characteristic when considering replacement with another company's product.
- Do not use the product in parallel connection.

## 2. Precautions for Handling and Storage

- The lifetime of semiconductor products is not permanent. Please consider the semiconductor's thermal fatigue caused by temperature cycle due to self-generated heat, and use the product within the  $\Delta T_{vj}$  power cycle lifetime and  $\Delta T_c$  power cycle lifetime. The  $\Delta T_c$  power cycle depends on the changes on the case temperature ( $T_c$ ) and is affected by the cooling conditions. Therefore, design and verify the heat generation and cooling conditions of semiconductor products in consideration of the target lifetime of the equipment.
- Do not use the IPM in an environment containing acids, organic substances, corrosive gases (hydrogen sulfide, sulfurous acid gas, etc.) and corrosive liquids (cutting fluid, etc.), as the IPM may oxidize or corrode and cause failures.
- The IPM is not designed for continuous use in high temperature and high humidity environment.
- The IPM is not radiation proof. Avoid using it in environments where radiation is received or in high altitudes.
- In environment with rapid temperature changes, condensation may occur which may affect the operation and appearance of the IPM.
- When designing for a new equipment, obtain the latest specifications and application notes and check the data.
- Store the product in an environment temperature of 5~35°C and humidity of 45 to 75% RH. If the storage area is very dry, a humidifier may be required. In such case, use only deionized or boiled water because the chlorine in tap water can corrode the terminals.
- It is necessary to prevent external pressure from being applied to the IPM during storage. Even when the IPM is stored in packing box, avoid stacking that may cause deformation of the packing box.
- Store the IPM with the lead terminals unprocessed. This is to avoid rust and other defects that may occur during processing, resulting in poor soldering.
- Use a non-static or conductive container or bag to store the IPM.
- Under the above storage conditions, use the IPM within one year.

### 3. Notice

- (1) This content is subject to change without notice due to changes in product specifications or for other reasons. In case of using a product described in this document, please obtain the latest specification and check the data.
- (2) Do not use the product described in this specification for the following applications.  
Aerospace equipment, airborne equipment, nuclear power control equipment, submarine relay equipment, medical equipment, etc.
- (3) The product described in this application manual are intended for use in general electronic equipment (such as compressor motor drive for air conditioner, fan motor drive for air conditioner). If you intend to use the product for a special purpose, please contact Fuji Electric Co., Ltd. or its sales representative before designing.
- (4) Fuji Electric Co., Ltd. is constantly striving to improve product quality and reliability. However, semiconductor products can fail with a certain probability. Take measures to ensure safety, such as redundant design, fire prevention design, and malfunction prevention design, so that failure of Fuji Electric's semiconductor products does not result in damage to property or other social damages due to personal injury, fire, etc.,
- (5) If the IPM is used outside the range described in this application note, we cannot guarantee it. If a phenomenon outside the scope of this specification occurs using IPM, please contact Fuji Electric.
- (6) If you have any questions or any unclear matter in this specification and the application note, please contact Fuji Electric Co., Ltd. or its sales agencies. Neither Fuji Electric Co., Ltd. nor its agencies shall be liable for any injury or damage caused by any use of the products not in accordance with instruction set forth herein.
- (7) The application examples described in this specification only explain typical ones that used Fuji Electric's semiconductor products. This specification never ensure to enforce the industrial property and other rights, nor license the enforcement rights.
- (8) No copying or reproduction of this document, in part or in whole, is permitted without the consent of Fuji Electric Co., Ltd.