

Fuji Small IPM (Intelligent Power Module)

P633A Series

6MBP**XS*060-50

Chapter 4 Power Terminals

Application Manual

Cautions

This Instruction contains the product specifications, characteristics, data, materials, and structures as of June 2021. The contents are subject to change without notice for specification changes or other reason. When using a product listed in this Instruction be sure to obtain the latest specifications.

The application examples in this note show the typical examples of using Fuji products and this note shall neither assure to enforce the industrial property including some other rights nor grant the license.

Although Fuji Electric Co., Ltd. continually strives to enhance product quality and reliability, a small percentage of semiconductor products may become faulty. When using Fuji Electric semiconductor products in your equipment, be sure to take adequate safety measures such as redundant, flame-retardant and fail-safe design in order to prevent a semiconductor product failure from leading to a physical injury, property damage or other problems.

The products described in this application manual are manufactured with the intention of being used in the following industrial electronic and electrical devices that require normal reliability.

- Compressor motor inverter
- Fan motor inverter for room air conditioner
- Compressor motor inverter for heat pump applications, etc.

If you need to use a semiconductor product in this application note for equipment requiring higher reliability than normal, such as listed below, be sure to contact Fuji Electric Co., Ltd. to obtain prior approval. When using these products, take adequate safety measures such as a backup system to prevent the equipment from malfunctioning when a Fuji Electric's product incorporated in the equipment becomes faulty.

- Transportation equipment (mounted on vehicles and ships)
- Trunk communications equipment
- Traffic-signal control equipment
- Gas leakage detectors with an auto-shutoff function
- Disaster prevention / security equipment
- Safety devices, etc.

Do not use a product in this application note for equipment requiring extremely high reliability such as:

- Space equipment • Airborne equipment • Atomic control equipment
- Submarine repeater equipment • Medical equipment

All rights reserved. No part of this application note may be reproduced without permission in writing from Fuji Electric Co., Ltd.

If you have any question about any portion of this application note, ask Fuji Electric Co., Ltd. or its sales agencies. Neither Fuji Electric Co., Ltd. nor its agencies shall be liable for any injury or damage caused by any use of the products not in accordance with instructions set forth herein.

Chapter 4 Power Terminals

1. Connection of Bus Input terminal and Low Side Emitters	4-2
2. Setting of Shunt Resistor of Over Current Protection	4-3

In this chapter, the guideline and precautions in circuit design on the power terminals, such as how to determine the resistance of shunt resistor are explained.

1. Connection of bus input terminal and low side emitters

<Description of the power terminals>

Table 4-1 shows the detail about the power terminals.

Table 4-1 Detail description of power terminals

Terminal Name	Description
P	Positive bus voltage input terminal It is internally connected to the collector of the high side IGBTs. In order to suppress the surge voltage caused by the wiring or PCB pattern inductance of the bus voltage, connect a snubber capacitor close to this pin. (Typically metal film capacitors are used)
U,V,W	Motor output terminal Inverter output terminals for connecting to motor load.
N(U),N(V),N(W)	Negative bus voltage input terminals These terminals are connected to the low side IGBT emitter of the each phase. In order to monitor the current on each phase, shunt resistors are inserted between these terminals and the negative bus voltage input (power ground).

<Recommended wiring of shunt resistor and snubber capacitor>

- External current sensing resistors are applied to detect over current (OC) condition or phase currents. Long wiring patterns between the shunt resistor and the product will cause excessive surge that might damage internal IC and current detection components. To reduce the pattern inductance, the wiring between the shunt resistors and the product should be as short as possible.
- As shown in the Fig.4-1, snubber capacitors should be connected at the right location to suppress surge voltage effectively. If the snubber capacitor is connected at the wrong location "A" as shown in the Fig.4-1, the snubber capacitor cannot suppress the surge voltage effectively because inductance of wiring is not negligible.
- If the capacitor is connected at the location "B", the charging and discharging currents generated by wiring and the snubber capacitor will appear at the shunt resistor. This will impact the current sensing signal and the OC protection level will be lower than the calculated design value. Location "C" is recommended. Although the suppression effect when the snubber capacitor is connected at location "B" is greater than location "A" or "C", location "C" is a reasonable position considering the impact to the current sensing accuracy. Generally a 0.1 ~ 0.22 μ F snubber is recommended.

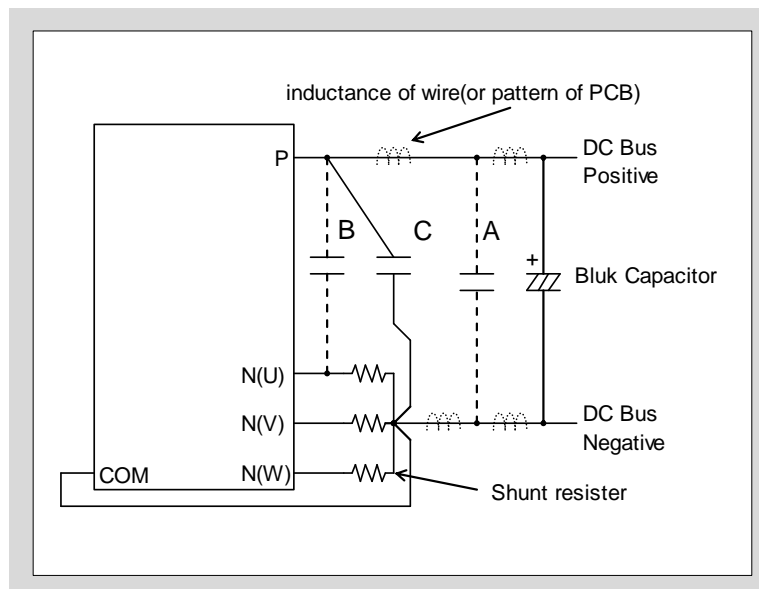

Fig.4-1 Recommended wiring of shunt resistor and snubber capacitor

2. Setting of Shunt Resistor of Over Current Protection

<Selecting current sensing shunt resistor>

The value of current sensing resistor is calculated by the following equation :

$$R_{Sh} = \frac{V_{IS(ref)}}{I_{OC}} \quad (4.1)$$

- Where $V_{IS(ref)}$ is the over current (OC) protection reference voltage level of the product and I_{OC} is the current of OC detection level. $V_{IS(ref)}$ is 0.455V(min.), 0.48V(typ.) and 0.505V(max.). And R_{Sh} is the Resistance of the shunt resistor.
- The maximum value of OC level should be set lower than the repetitive peak collector current in the specification datasheet of this product, taking into consideration the variation in shunt resistance.
- For example, if OC level is set at 45A, the recommended value of the shunt resistor is calculated as:

$$R_{Sh(min)} = \frac{V_{IS(ref)(max)}}{I_{OC}} = \frac{0.505}{45} = 11.2[m\Omega] \quad (4.2)$$

- Where $R_{Sh(min)}$ is the minimum resistance of the shunt resistor. It should be noted that a proper resistance should be chosen considering OC level required in practical application.

<Filter delay time setting of over current protection>

- An external RC filter is necessary in the over current sensing circuit to prevent unnecessary over current protection caused by noise. The RC time constant is determined by the applying time of noise and the short circuit withstand capability of IGBTs. It is recommended to be set approximately 0.7 μ s.
- When the voltage across the shunt resistor exceeds the OC level, the filter delay time t_{delay} that delays the rises of input voltage of IS terminal to the OC level is caused by the RC filter delay time constant and is given by:

$$t_{\text{delay}} = -\tau \cdot \ln \left(1 - \frac{V_{\text{IS(ref)(max)}}}{R_{\text{Sh}} \cdot I_{\text{p}}} \right) \quad (4.3)$$

- Where τ is the RC time constant, I_{p} is the peak current flowing through the shunt resistor. In addition, there is a shut down propagation delay $t_{\text{d(IS)}}$ of OC.
- Therefore, the total time t_{total} from OC triggered to shut down of the IGBT is given by:

$$t_{\text{total}} = t_{\text{delay}} + t_{\text{d(IS)}} \quad (4.4)$$

- The total delay time t_{total} should be shorter than the short circuit withstands capability of IGBT. Please confirm the proper delay time in actual equipment.