

Small IPM (Intelligent Power Module)

P642 Series

6MBP**XT*065-50

Mounting Instruction

Cautions

This Instruction contains the product specifications, characteristics, data, materials, and structures as of October 2022. The contents are subject to change without notice for specification changes or other reason. When using a product listed in this Instruction be sure to obtain the latest specifications.

The application examples in this note show the typical examples of using Fuji products and this note shall neither assure to enforce the industrial property including some other rights nor grant the license.

Although Fuji Electric Co., Ltd. continually strives to enhance product quality and reliability, a small percentage of semiconductor products may become faulty. When using Fuji Electric semiconductor products in your equipment, be sure to take adequate safety measures such as redundant, flame-retardant and fail-safe design in order to prevent a semiconductor product failure from leading to a physical injury, property damage or other problems.

The product introduced in this Application note is intended for use in the following electronic and electrical equipment which requires ordinary reliability:

- Inverter for Compressor motor or fan motor for Room Air Conditioner
- Inverter for Compressor motor for heat pump applications.

If you need to use a semiconductor product in this application note for equipment requiring higher reliability than normal, such as listed below, be sure to contact Fuji Electric Co., Ltd. to obtain prior approval. When using these products, take adequate safety measures such as a backup system to prevent the equipment from malfunctioning when a Fuji Electric's product incorporated in the equipment becomes faulty.

- Transportation equipment (mounted on vehicles and ships)
- Trunk communications equipment
- Traffic-signal control equipment
- Gas leakage detectors with an auto-shutoff function
- Disaster prevention / security equipment
- Safety devices, etc.

Do not use a product in this application note for equipment requiring extremely high reliability such as:

- Space equipment • Airborne equipment • Atomic control equipment
- Submarine repeater equipment • Medical equipment

All rights reserved. No part of this application note may be reproduced without permission in writing from Fuji Electric Co., Ltd.

If you have any question about any portion of this application note, ask Fuji Electric Co., Ltd. or its sales agencies. Neither Fuji Electric Co., Ltd. nor its agencies shall be liable for any injury or damage caused by any use of the products not in accordance with instructions set forth herein.

CONTENTS

Chapter 1	Precautions during transportation and storage	1-1
Chapter 2	Precautions in unpacking	2-1
	1. Removing the pin from the tube	2-1
	2. Picking out the Small IPM from the stick	2-3
Chapter 3	Through hole design for PCB	3-1
Chapter 4	Spacer	4-1
Chapter 5	Application of thermal grease	5-1
Chapter 6	Heat sink selection	6-1
	1. Selection	6-1
	2. Shape	6-2
	3. Mounting (tightening)	6-2
Chapter 7	Soldering to Printed Circuit Board	7-1
Chapter 8	Appendix	8-1
	1. Stencil mask drawing for thermal grease application (recommended)	8-1
	2. Isolation distance of heat sink	8-2

This chapter describes the precautions during transportation and storage for the product.

1. Precautions during transportation and storage

- The product should be stored at a normal temperature of 5 to 35°C and relative humidity of 45 to 75%, otherwise the product might be corroded or destructed, or its lifetime. If the storage area is very dry, a humidifier may be required. In such a case, use only deionized water or boiled water, since the chlorine in tap water may corrode the leads.
- In case of storage environment with rapid temperature changes, condensation will be occurred on the surface of the product. In order to avoid the condensation, the product shall be stored in steady temperature environment if possible.
- Should not be stored or used in an environment where it is exposed to acids, organic substances, or corrosive gas (hydrogen sulfide, sulfurous acid gas etc.) or in a dusty place.
- When stored, it is necessary to prevent external pressure to the product. Stacking that may deform the outer box shall be avoided even when it is packed in the outer box.
- Transport the cardboard box with the appropriate side facing up. This is to prevent unexpected stress being applied to the product, which may cause bending of the terminals or distortion in the resin package of the product. Throwing or dropping the product can cause severe damage to the product. Also, it is necessary to pay attention to rain and freezing to avoid wetting, as it may cause damage or destruction. The environmental conditions such as temperature and humidity during transportation described in the specifications shall be strictly observed.
- The product should be stored with the lead terminals remaining unprocessed. It is necessary to avoid rusting etc. due to scratches during processing, resulting in poor soldering.
- The containers and bags for storing the product should be non-static or conductive.
- Under the above storage condition, use the product within one year.

This chapter describes the precautions in unpacking for the product.

2. Precautions in unpacking

1 Removing the pin from the tube

- The products are packaged in tubes that are pinned at both ends.
- Remove the pin on one side to pick out the product from the tube.
- If the pin and the product are in contact with each other when removing the pin, a strong impact might be applied to the product, which may cause deformation or damage to the product terminals. Make a gap between the pin and the product when removing the pin.
- The recoil of removing the pins may cause deformation or damage to the terminals of the product, so remove the pins with holding them.
- If the product falls out from the tube when removing the pins, it may cause a strong impact to the product, causing the product terminals to be deformed or damaged. Remove the pin with the tube opening facing up.
- It is recommended to use a remover (removal jig) to remove the pins. The following shows how to remove the pins using the remover.
- Pin removing method using remover (removal jig).

1. Make a gap between the pin and the product. (See Fig. 2-1)

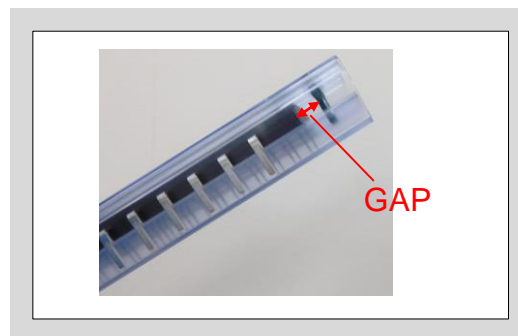

Fig. 2-1 Gap between the pin and the product

2. Push the pointed end of the pin with your index finger, and make a gap between the pin and the tube to insert the remover removal part as shown in Fig. 2-2. (See Fig. 2-3)



Fig. 2-2 Example of remover (removal jig)

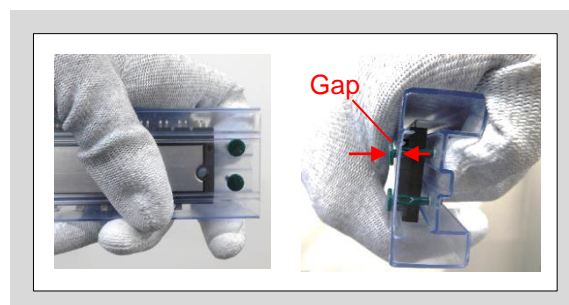

Fig. 2-3 Gap between the pin and the tube

3. Insert the removal part of the remover into the gap between the pin and the tube. (See Fig. 2-4)

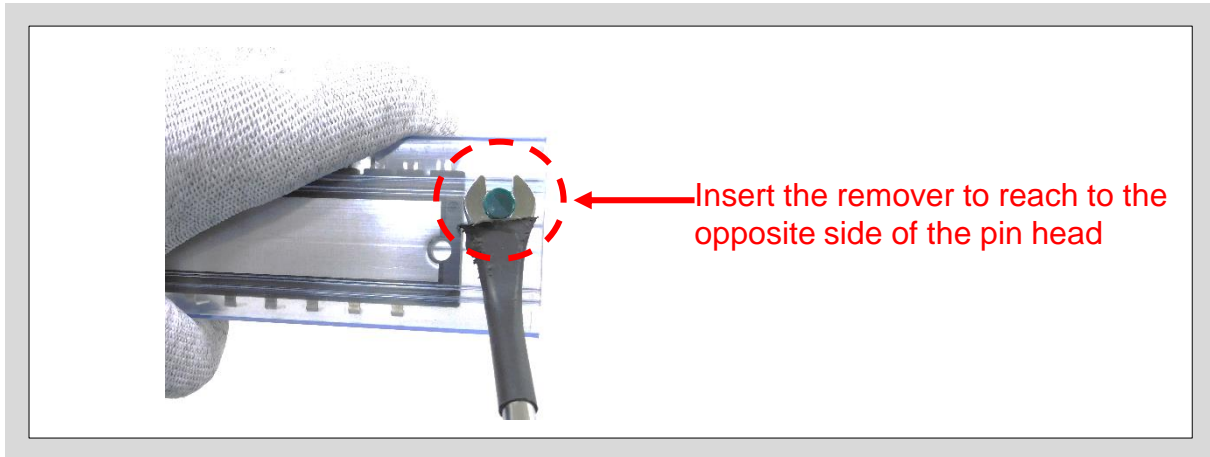

Fig. 2-4 Insert remover

4. Hold the pin with your finger and remove the pin with the tube opening facing up. (See Fig. 2-5, 2-6)

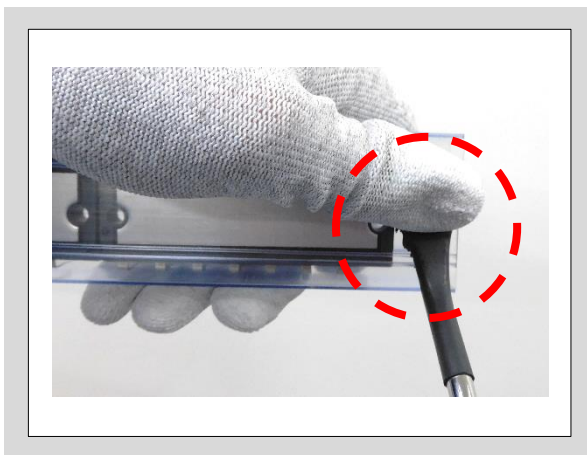

Fig. 2-5 How to hold the pin

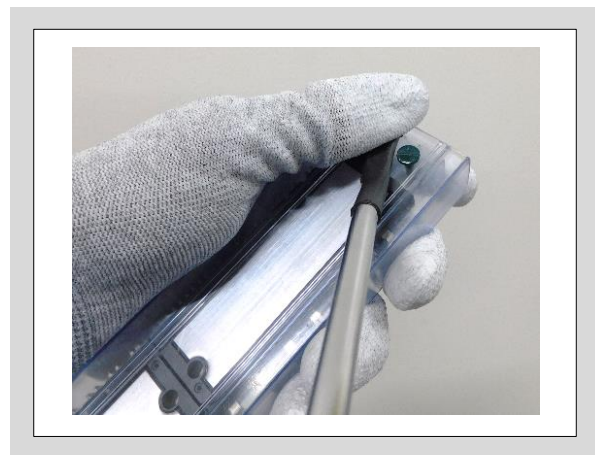

Fig. 2-6 Tube opening orientation

2 Removing the product from the tube

- Since the elements installed in the Small IPM are extremely weak to electrostatic discharge, appropriate ESD countermeasures are necessary in the assembly environment within the range described in the specifications. In particular, when removing it out from the tube, it is most likely to cause electrical damage to the product.
- When removing the product, do not strongly collide the products with each other or touch the product terminals to the tube. A strong impact on the product may cause deforming or damage to the product terminals.

This chapter describes the through hole design for PCB attaching to the product.

3. Through hole design for PCB

Figures 3-1 to 3-3 show examples of recommended through hole dimensions and through hole layout designs.

- The through hole dimensions are the inner diameter after plating (dimension unit: mm).
- If the terminal cross-sectional dimensions / through hole clearance is too large, solderability may be impaired. Also, if the land diameter is too large, solder bridges are likely to occur.
- The hole size and land size should be optimized as appropriate, taking into consideration the printed circuit board processing accuracy and mounting method.

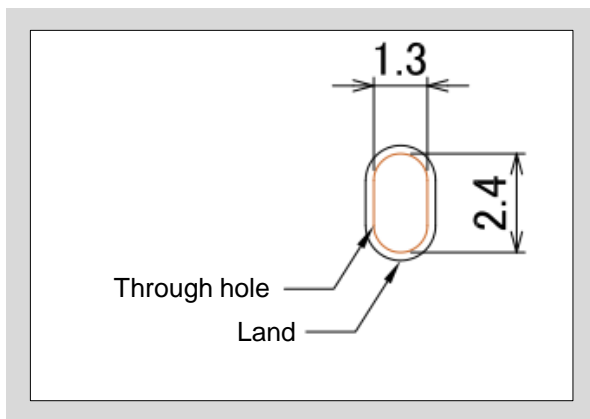

Fig. 3-1 Control side through hole dimensions

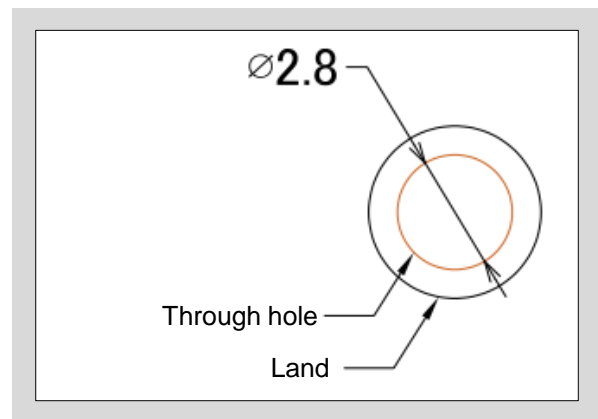

Fig. 3-2 Power side through hole dimensions

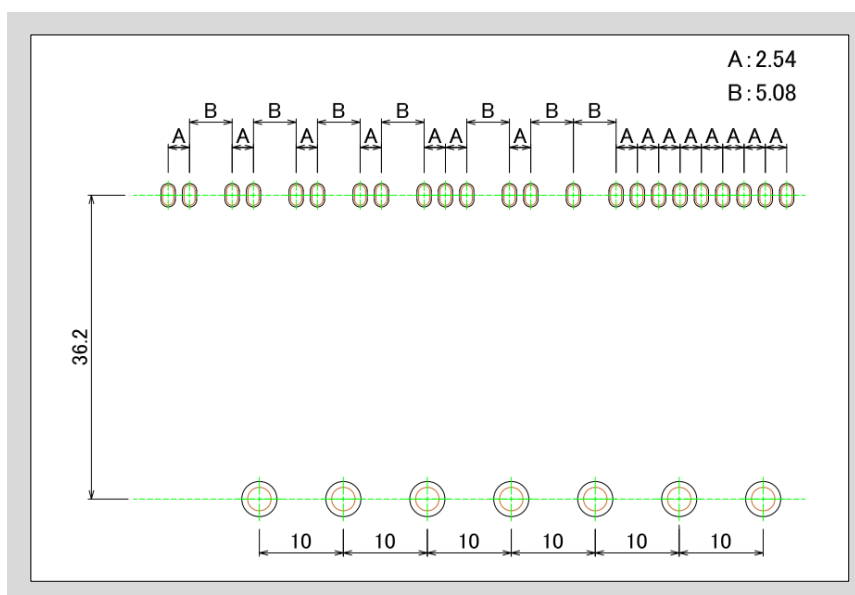

Fig. 3-3 Through hole layout

This chapter describes the spacer for PCB attaching to the product.

4. Spacer

- When using spacer between the PCB and the product for alignment during soldering to printed circuit board, it is recommended to support the product at the hatched area as shown in Fig. 4-1.
- Select a spacer material that does not cause contamination or corrosion.

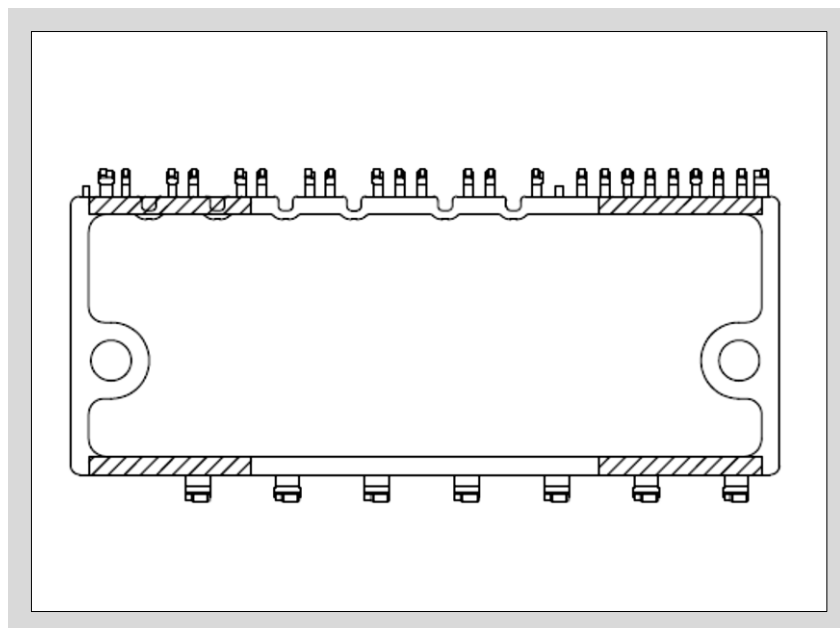

Fig. 4-1 Spacer installation position

This chapter describes the thermal grease application for the product.

5. Application of thermal grease

- It is recommended to apply thermal grease between the product's aluminum base and the heat sink to ensure heat dissipation to the heat sink. If the properties, amount, and application method of the thermal grease is not appropriate, it may result in poor heat dissipation and lead to thermal failure. Table 5-1 shows the recommended thermal grease properties and thickness
- Assuming that the thickness is uniform, the required amount (weight) of thermal grease can be calculated from the following formula.

$$\text{Thermal grease weight (g)} \times 10^4 = \text{Thermal grease thickness (\mu m)} \times \text{Aluminum base area of product (cm}^2\text{)} \times \text{Density of thermal grease (g/cm}^3\text{)}$$

- We recommend using the stencil mask method to control the appropriate thermal grease thickness (Fig. 5-1). The recommended stencil mask pattern is shown in appendix.
- It is recommended to check the spread of thermal grease by removing the product after mounting and check the extent of spreading.
- In the case of liquid cooling, the temperature difference (temperature gradient) between the heat sink temperature and the temperature inside the product becomes large. When mounting the product to heat sink, secure a thermal grease coating amount that can absorb the distortion due to the difference in thermal expansion when the temperature gradient is large.
- In the case of a multiple structure heat sink, the number of fastening parts increases and heat transfer (diffusion) becomes uneven. Therefore, it is necessary to suppress the distortion, such as securing the thermal grease coating amount in consideration of the generated distortion during design.

Table 5-1. Recommended properties of thermal grease

	Unit	Recommended value
Penetration (typ.)	-	328
Thermal conductivity	W/m·K	0.90
Thermal grease thickness	μm	100±30

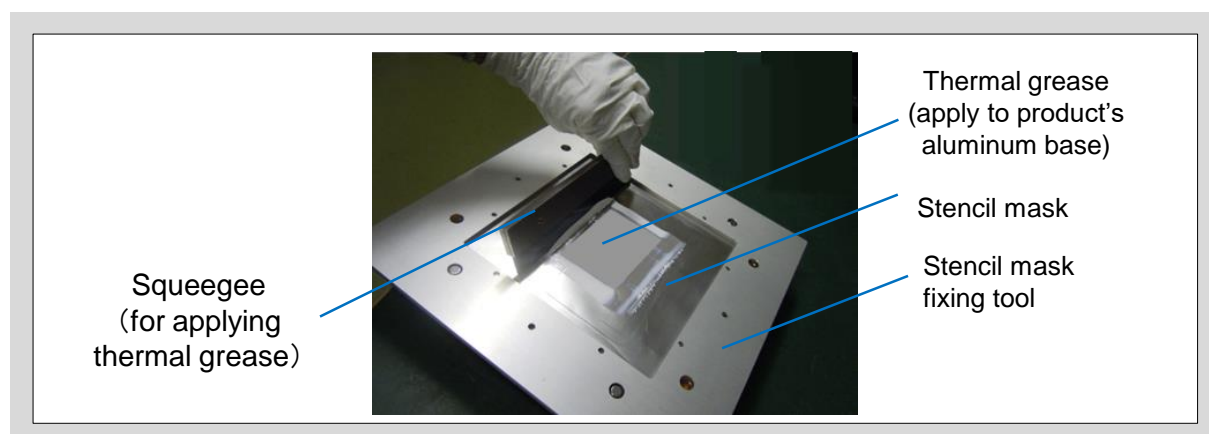

Fig. 5-1 Thermal grease application

This chapter describes the heat sink selection for the product.

6. Heat sink selection

1 Selection

- The junction temperature T_{vj} should not exceed the maximum junction temperature rating for safe operation. Heat sink (cooling device) should be designed to ensure that T_{vj} is always below the maximum junction temperature rating.
- If the IGBT or FWD junction temperature is higher than the maximum junction temperature rating, it might cause damage to the chips. Some types of the products have the over heating (OH) protection function which works when the LVIC chip temperature exceeds the maximum junction temperature rating. However, if the temperature rises too quickly, the OH protection might not work.
- When selecting a heat sink, please verify the chip temperature T_{vj} by measuring T_c at the position shown in Figure 6-1, and calculating the T_{vj} from device power dissipation and thermal resistance. In addition, this product has a built-in temperature sensor, and T_{vj} can be confirmed by the analog voltage that is output according to the LVIC chip temperature. Please refer to it when selecting the heat sink.
- For more detail design, please refer to "IGBT Module Application Manual (REH984e)" and "Small IPM Application Manual (MT6M15234b)".

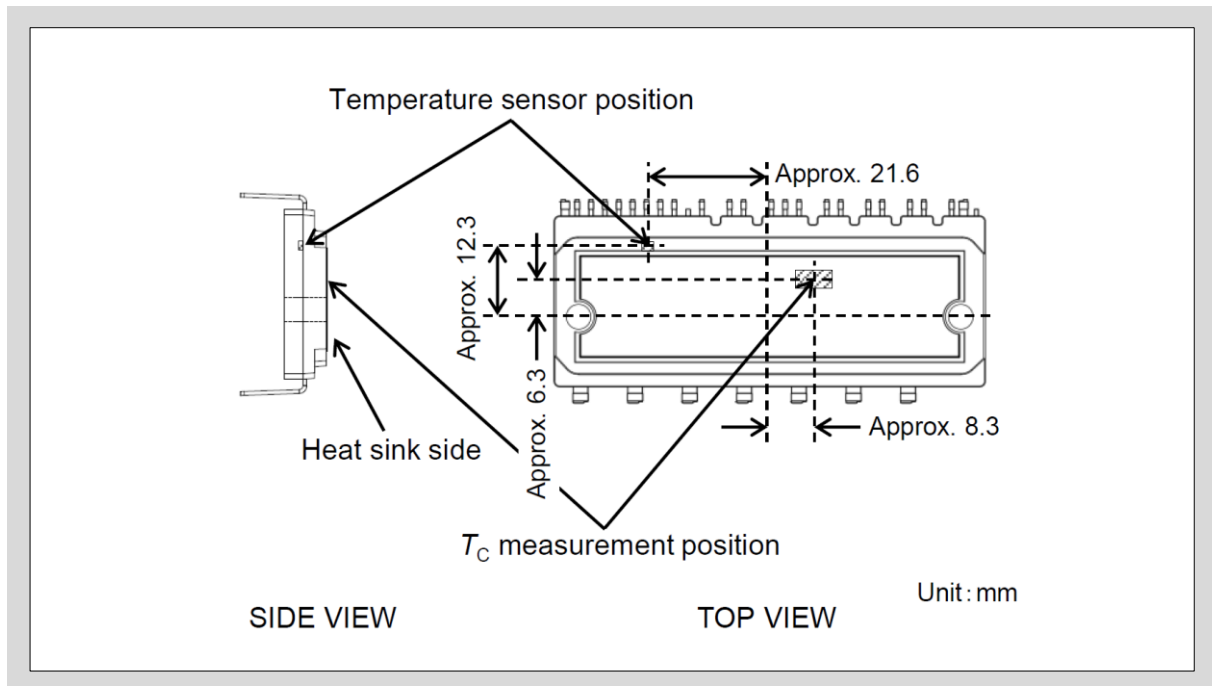

Fig. 6-1 Temperature sensing and T_c measurement points

2 Shape

- As shown in Fig. 6-2, the heat sink flatness should be $0\mu\text{m}/100\text{mm}$ to $+100\mu\text{m}/100\text{mm}$, and the surface roughness (R_z) should be less than $10\mu\text{m}$.
- If the heat sink surface is concave, a gap occurs between the heat sink and the product, leading to deterioration of cooling efficiency.
- If the flatness is $+100\mu\text{m}/100\text{mm}$ or more, the aluminum base of the product is deformed and cracks could occur in the internal isolating substrates.

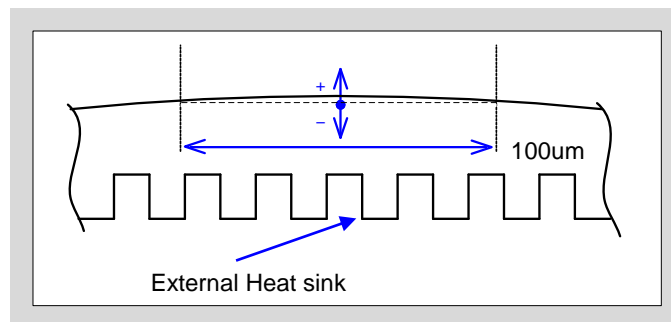

Fig. 6-2 The measurement point of heat sink flatness

3 Mounting (tightening)

- When mounting the product to a heat sink, the following fastening order is recommended. Uneven fastening due to excessive torque might lead to destruction or degradation of the chip.
- Standard: Metric screw JIS B 1111
- Screw length: 16mm
- Screw head shape: Pan shape (head diameter 7.8 mm)
- Material: Stainless
- Use flat washers (JIS B1256 recommended). Washer head type screws can be used as well.
- The mounting (tightening) that support the load of structure such as heat sink or printed circuit board by the product should be avoided.
- When mounting this product together with other components to the heat sink, ensure the flatness of the components mounted on the printed circuit board before mounting.

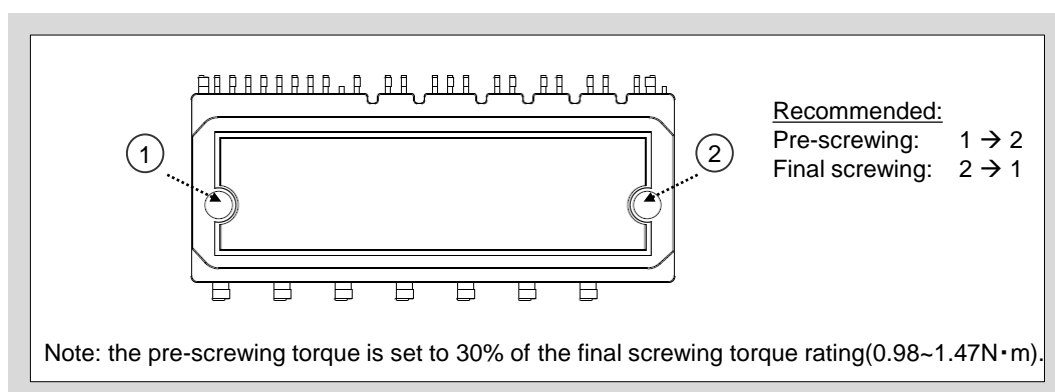

Fig. 6-3 Recommended screw fastening procedure

This chapter describes the soldering to printed circuit board for the product.

7. Soldering to Printed Circuit Board

- The product's temperature during soldering might exceed the maximum temperature rating. To prevent damage to the product and to ensure reliability, please use the following soldering temperature.

Table 7-1. Soldering temperature and duration

Methods	Soldering Temp. & Time
Dip soldering	260±5°C, 10±1sec

- A stopper is provided on the terminal to prevent the immersion depth of the terminal from coming too close to the product body. Use this stopper to secure the required distance from the printed circuit board and prevent the product body from being immersed in the solder bath during flow soldering.
- It is not recommended to reuse the product after it is removed from the printed circuit board because there is a possibility that the removed product was subjected to thermal or mechanical damage during the removal process.

This chapter describes the appendix for mounting of the product.

8. Appendix

1 Stencil mask drawing for thermal grease application (recommended)

Package No. : P642

This figure shows the view from the aluminum base surface.

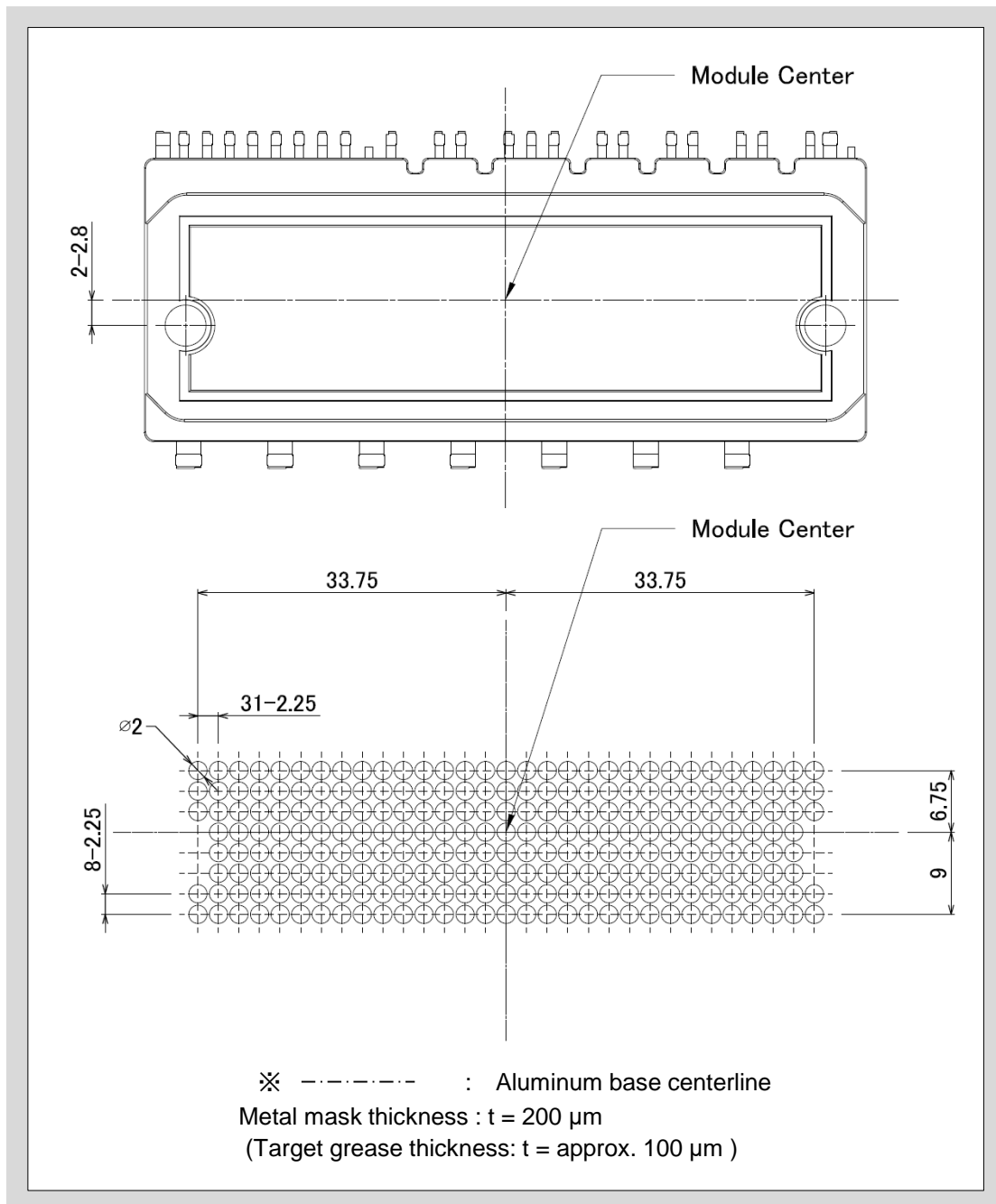

Fig. 8-1 Stencil mask drawing for thermal grease application (recommended)

2 Isolation distance of heat sink

- By processing the heat sink as shown in Fig. 8-2, it is possible to secure a clearance distance of 5.08 mm or more in accordance with UL.

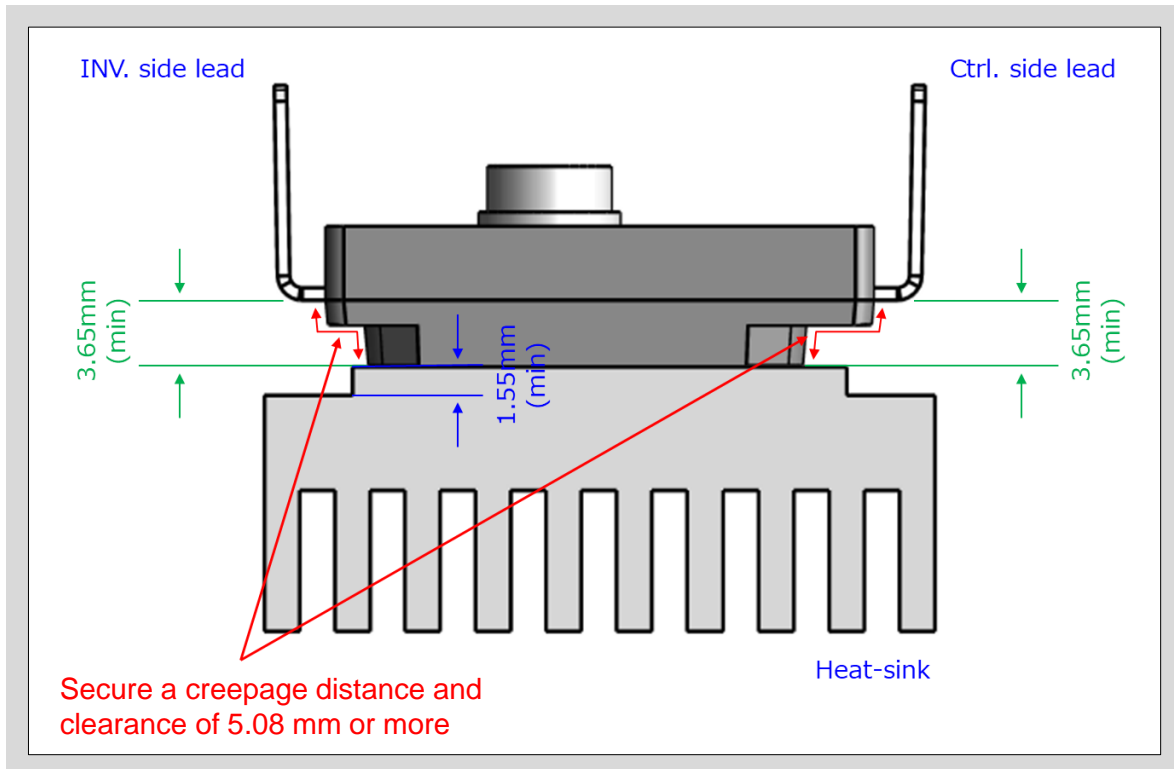

Fig. 8-2 Isolation distance of heat sink