

Small IPM (Intelligent Power Module)

P633C Series

6MBP\*\*XS\*065-50

## Application Manual

## Cautions

This Instruction contains the product specifications, characteristics, data, materials, and structures as of August 2023. The contents are subject to change without notice for specification changes or other reason. When using a product listed in this Instruction be sure to obtain the latest specifications.

The application examples in this note show the typical examples of using Fuji products and this note shall neither assure to enforce the industrial property including some other rights nor grant the license.

Although Fuji Electric Co., Ltd. continually strives to enhance product quality and reliability, a small percentage of semiconductor products may become faulty. When using Fuji Electric semiconductor products in your equipment, be sure to take adequate safety measures such as redundant, flame-retardant and fail-safe design in order to prevent a semiconductor product failure from leading to a physical injury, property damage or other problems.

The products described in this application manual are manufactured with the intention of being used in the following industrial electronic and electrical devices that require normal reliability.

- Compressor motor inverter
- Fan motor inverter for room air conditioner
- Compressor motor inverter for heat pump applications, etc.

If you need to use a semiconductor product in this application note for equipment requiring higher reliability than normal, such as listed below, be sure to contact Fuji Electric Co., Ltd. to obtain prior approval. When using these products, take adequate safety measures such as a backup system to prevent the equipment from malfunctioning when a Fuji Electric's product incorporated in the equipment becomes faulty.

- Transportation equipment (mounted on vehicles and ships)
- Trunk communications equipment
- Traffic-signal control equipment
- Gas leakage detectors with an auto-shutoff function
- Disaster prevention / security equipment
- Safety devices, etc.

Do not use a product in this application note for equipment requiring extremely high reliability such as:

- Space equipment    • Airborne equipment    • Atomic control equipment
- Submarine repeater equipment    • Medical equipment

All rights reserved. No part of this application note may be reproduced without permission in writing from Fuji Electric Co., Ltd.

If you have any question about any portion of this application note, ask Fuji Electric Co., Ltd. or its sales agencies. Neither Fuji Electric Co., Ltd. nor its agencies shall be liable for any injury or damage caused by any use of the products not in accordance with instructions set forth herein.

## Chapter 1 Product Outline

1. Introduction	1-2
2. Product Lineup	1-5
3. Definition of Type Name and Marking Spec	1-6
4. Outline Dimensions	1-8
5. Absolute Maximum Ratings	1-10

This manual describes the following contents for Fuji IGBT Intelligent Power Module “Small IPM”

- Product outline
- Explanation of terminal symbols and terminology
- Detailed description and design guidelines for control and power terminals
- Recommended wiring and layout, along with mounting guidelines

## 1. Introduction

### <Product overview>

- IGBT modules used in inverters for compressors and air conditioner fans are developing rapidly in response to the growing demand for energy saving, equipment miniaturization and weight reduction.
- IGBTs are devices that combine the high-speed switching performance of power MOSFETs and the high-voltage, high-current capabilities of bipolar transistors, and are expected to further develop in the future.
- Among them, the IPM (Intelligent Power Module) is a 3-phase IGBT inverter bridge circuit with integrated gate drive circuits and protection circuits.

### <Product concept>

- 7th gen. IGBT/FWD technology realize low loss and energy saving of equipment.
- Guaranteed  $T_{vjop}=150^{\circ}\text{C}$  allows expansion of output current.
- High accuracy short-circuit protection detection expands the overload operation range.
- Compatible pin assignments, footprints, and mounting dimensions with conventional Small IPM.
- Product lineup of 650V/15A to 35A.
- Lower total loss against conventional products by improving the trade-off between Collector-Emitter saturation voltage  $V_{CE(sat)}$  and switching loss.
- Achieves low  $dv/dt$  and low switching loss compared to conventional products.

### <Internal circuit>

- Optimally designed IGBT drive circuit.
- The high-side control IC (HVIC) contains a high-voltage level shift circuit.
- This product can be driven directly by MCU (microcontroller) on both the high-side and low-side arms. The voltage level of the input signals are 3.3V or 5V.
- Since the wiring length between the internal drive circuit and IGBT is short and the impedance of the drive circuit is low, no reverse bias power supply is required.
- Normally, IPM device requires a total of four isolated control power supplies: one for the lower sides and three for the upper sides. However, since this IPM has built-in bootstrap diodes (BSD), isolated power supplies for the high-sides are not needed.

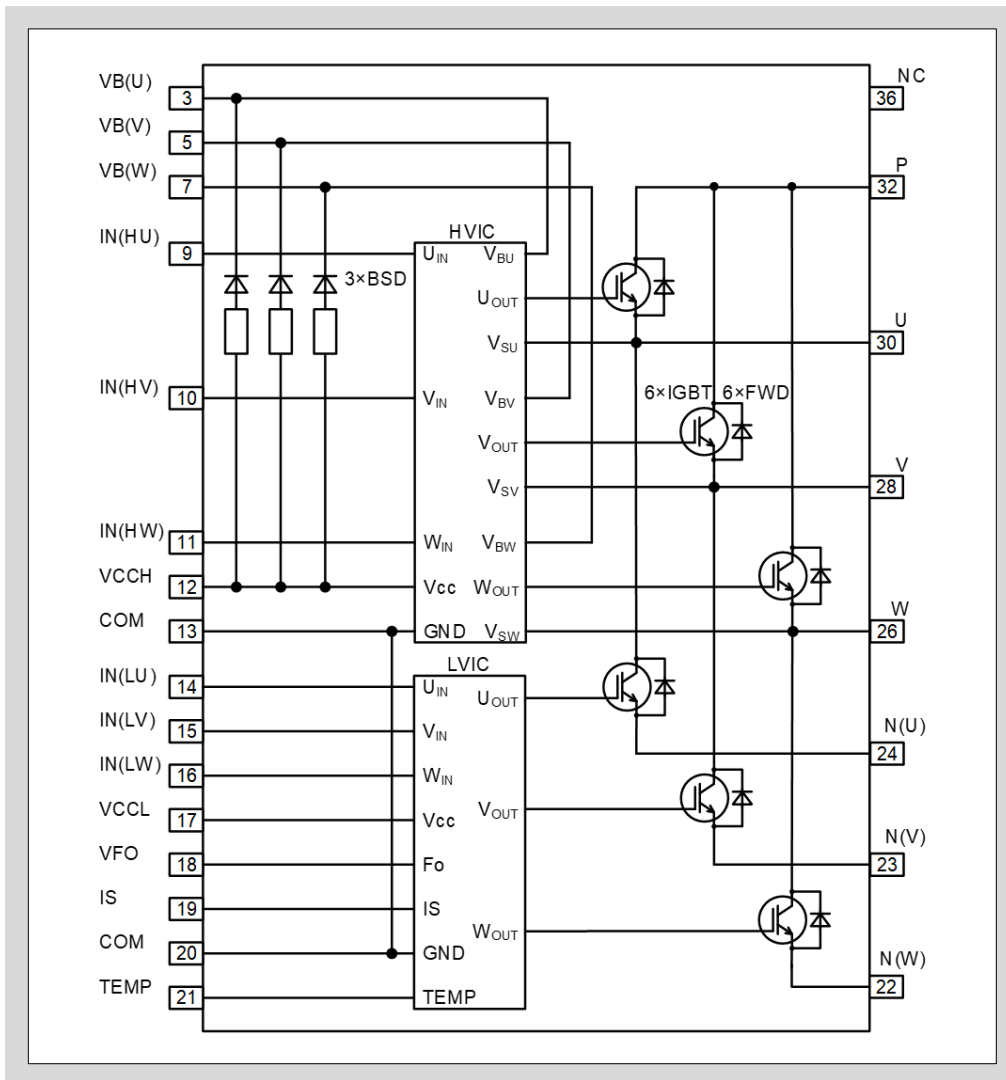

Fig.1-1 Block Diagram of Internal Circuit

### <Built-in protection circuits>

- The following built-in protection circuits are incorporated in the product:
  - OC: Over current protection
  - UV: Under voltage protection for power supplies of control IC
  - LT: Temperature sensor output function
  - OH: Overheating protection (only applied to some products)
  - FO: Fault alarm signal output
- The OC protection circuits protect the IGBT against over current, load short-circuit or arm short-circuit.
- The protection circuit can monitor the emitter current using external shunt resistor in each low-side IGBT and thus it can protect the IGBT against arm short-circuit.
- The UV protection circuit operates when the control power supply voltage drops below the trip voltage level. It is built into all of the IGBT drive circuits.
- The OH protection circuit protects the product from overheating. The OH protection circuit is built into the control IC of the low-side arm (LVIC).
- The temperature sensor output function is built into the LVIC and converts the detected temperature into analog voltage output.
- The FO function outputs a fault signal when the circuit detects abnormal conditions, thus making it possible to shut down the system reliably and preventing destruction by outputting the fault signal to the microprocessor unit controlling the product.

### <Compact package>

- This product uses high heat dissipation aluminum insulated metal substrate (IMS), which improves the heat radiation.
- The control input terminals have a shrink pitch of 1.778mm (70mil).
- The power terminals have a standard pitch of 2.54mm (100mil).

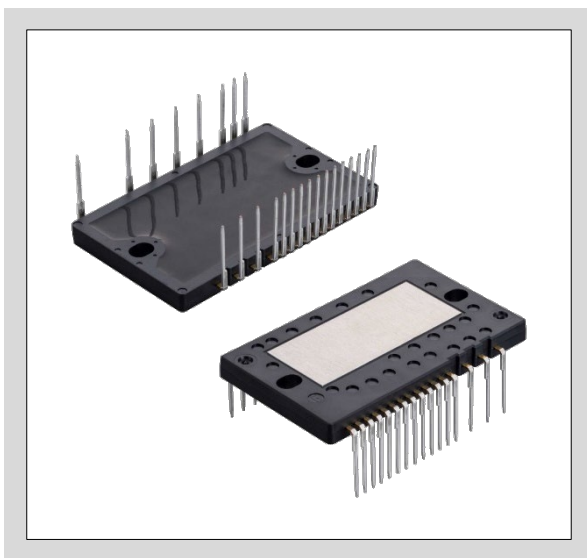

Fig.1-2 Package overview

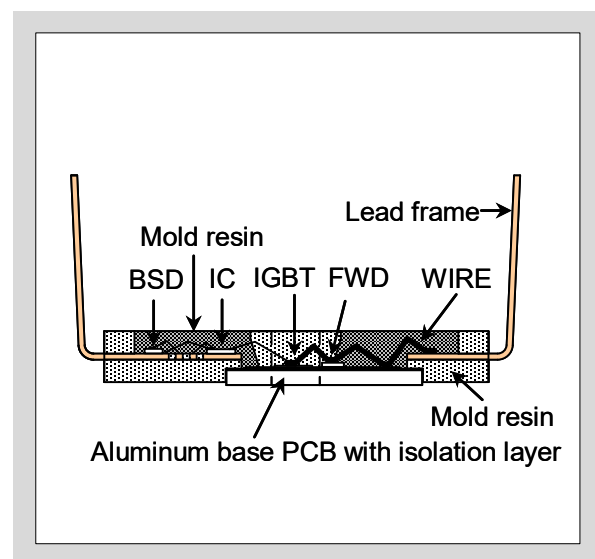

Fig.1-3 Package cross section diagram

## 2. Product Lineup

Table. 1-1 Lineup

Package							Rating of IGBT		Type name	Isolation Voltage [Vrms]
							Voltage [V]	Current [A]		
P633C	✓	-	✓	✓	✓	-	650V	15A	<b>6MBP15XSJ065-50</b>	1500Vrms Sinusoidal 60Hz, 1min. *1
								20A	<b>6MBP20XSJ065-50</b>	
								30A	<b>6MBP30XSJ065-50</b>	
								35A	<b>6MBP35XSJ065-50</b>	
		✓						15A	<b>6MBP15XSK065-50</b>	
								20A	<b>6MBP20XSK065-50</b>	
								30A	<b>6MBP30XSK065-50</b>	
								35A	<b>6MBP35XSK065-50</b>	

\*1 Between all shorted terminals and case

### 3. Definition of Type Name and Marking Spec

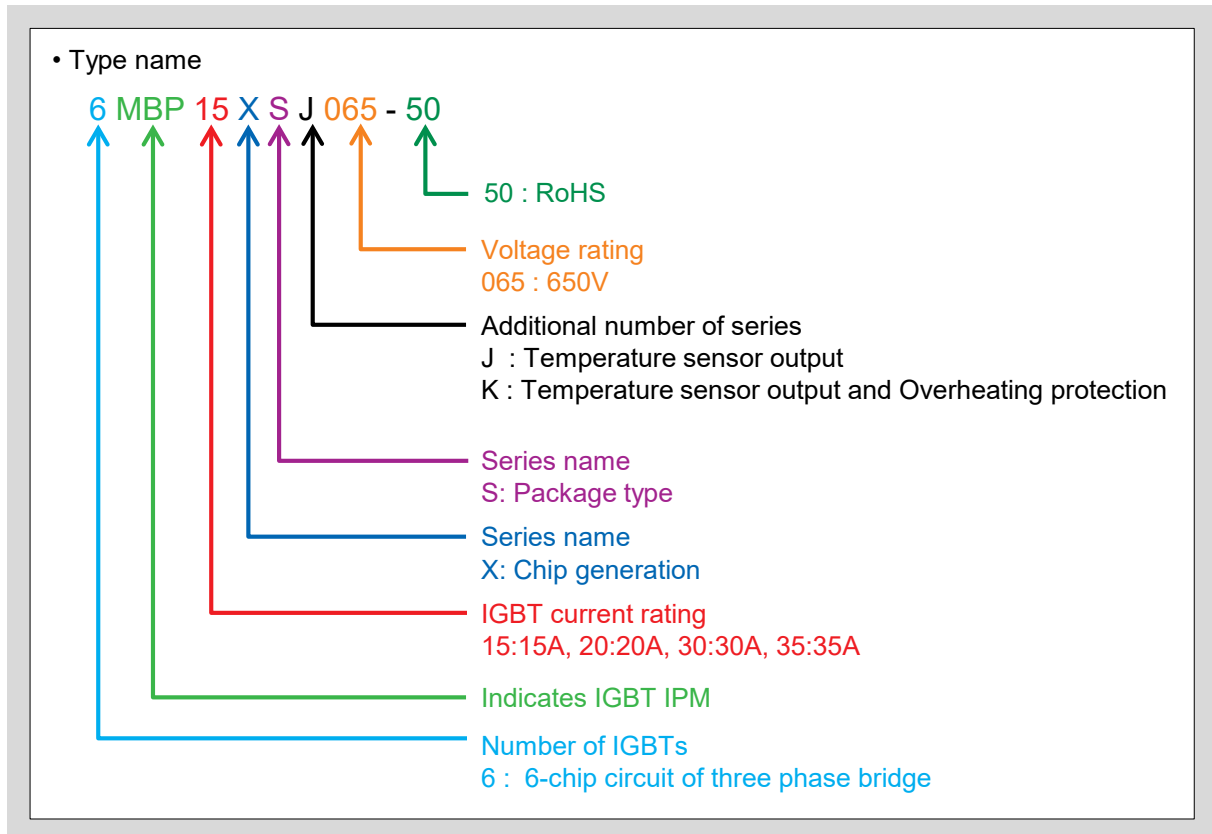

Fig.1-4 Part numbers



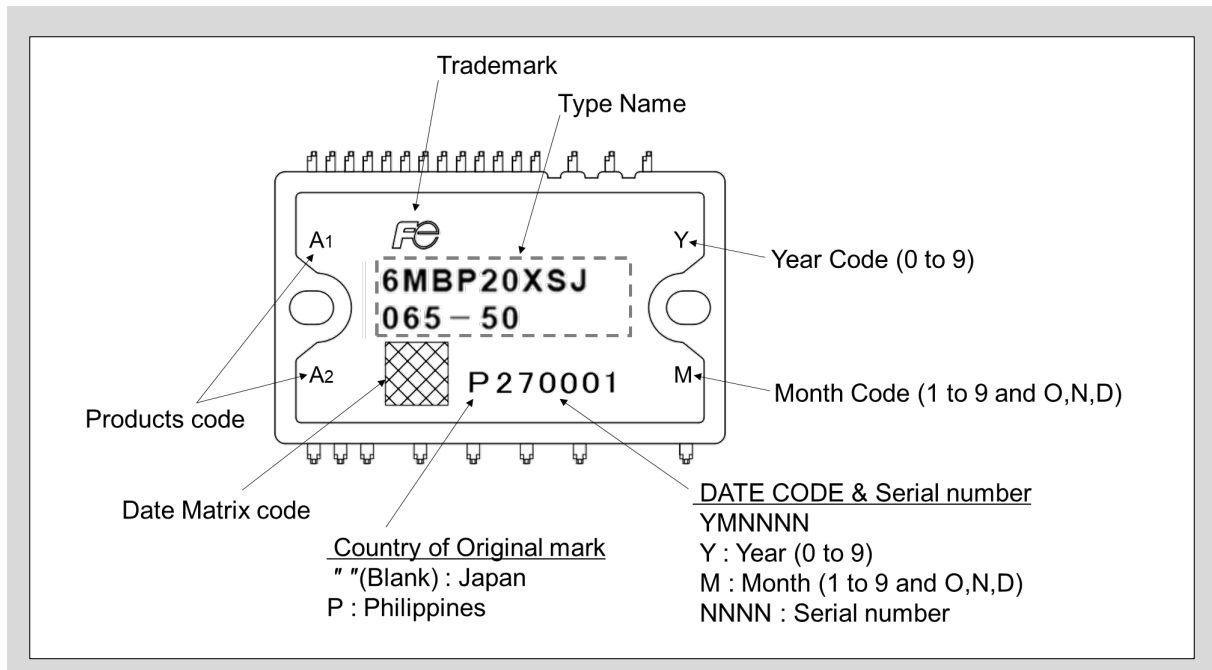

Fig.1-5 Marking Specification

Table. 1-2 Products code

TYPE NAME	PRODUCTS CODE	
	A1	A2
6MBP15XSJ065-50	L	J
6MBP15XSK065-50	L	K
6MBP20XSJ065-50	M	J
6MBP20XSK065-50	M	K
6MBP30XSJ065-50	O	J
6MBP30XSK065-50	O	K
6MBP35XSJ065-50	P	J
6MBP35XSK065-50	P	K



Table. 1-3 Pin assignment

Pin No.	Pin Name	Pin No.	Pin Name
3	VB(U)	22	N(W)
5	VB(V)	23	N(V)
7	VB(W)	24	N(U)
9	IN(HU)	26	W
10	IN(HV)	28	V
11	IN(HW)	30	U
12	VCCH	32	P
13	COM	36	NC
14	IN(LU)		
15	IN(LV)		
16	IN(LW)		
17	VCCL		
18	VFO		
19	IS		
20	COM		
21	TEMP		

## 5. Absolute Maximum Ratings

An example of the absolute maximum ratings of 6MBP20XSJ065-50 is shown in Table 1-4.

Table 1-4 Absolute Maximum Ratings at  $T_{vj}=25^{\circ}\text{C}$ ,  $V_{CC}=15\text{V}$  (unless otherwise specified)

Item	Symbol	Rating	Unit	Description
DC Bus Voltage	$V_{\text{DC(terminal)}}$	450	V	DC voltage that can be applied between P-N(U), N(V), N(W) terminals
Bus Voltage (Surge)	$V_{\text{DC(Surge,terminal)}}$	500	V	Peak value of the surge voltage that can be applied between P-N(U), N(V), N(W) terminals during switching operation
Collector-Emitter Voltage	$V_{\text{CE(chip)}}$	650	V	Maximum collector-emitter voltage of IGBT and repeated peak reverse voltage of FWD.
Collector Current	$I_{\text{C}}$	20	A	Maximum collector current for the IGBT chip. $T_c=25^{\circ}\text{C}$
Peak Collector Current	$I_{\text{CP}}$	40	A	Maximum pulse collector current for the IGBT chip. $T_c=25^{\circ}\text{C}$
Forward Current	$I_{\text{F}}$	20	A	Maximum forward current for the FWD chip. $T_c=25^{\circ}\text{C}$
Peak Forward Current	$I_{\text{FP}}$	40	A	Maximum pulse forward current for the FWD chip. $T_c=25^{\circ}\text{C}$
Collector Power Dissipation	$P_{\text{D\_IGBT}}$	41.0	W	Maximum power dissipation for one IGBT element at $T_c=25^{\circ}\text{C}$
FWD Power Dissipation	$P_{\text{D\_FWD}}$	33.9	W	Maximum power dissipation for one FWD element at $T_c=25^{\circ}\text{C}$
Self operation "DC Bus voltage" of circuit protection between upper-arm and lower-arm	$V_{\text{DC(sc)}}$	400	V	$V_{\text{CC}}=V_{\text{B}(\ast)}=13.5\sim 16.5\text{V}$ $T_{vj}=125^{\circ}\text{C}$ , arm short circuit, non-repetitive less than 2us.
Virtual Junction Temperature of Inverter Block	$T_{vj}$	+150	$^{\circ}\text{C}$	Maximum virtual junction temperature of the IGBT chips and the FWD chips. Operating life is limited by junction temperature and power cycle.
Operating Virtual Junction Temperature of Inverter Block	$T_{vjop}$	-40 ~ +150	$^{\circ}\text{C}$	Junction temperature of the IGBT and FWD chips during continuous operation. Operating life is limited by junction temperature and power cycle.

Table 1-5 Absolute Maximum Ratings at  $T_{vj}=25^{\circ}\text{C}$ ,  $V_{CC}=15\text{V}$  (Continued)

Item	Symbol	Rating	Unit	Descriptions
High-side Supply Voltage	$V_{CCH}$	-0.5 ~ 20	V	Voltage that can be applied between COM and $V_{CCH}$ terminal
Low-side Supply Voltage	$V_{CCL}$	-0.5 ~ 20	V	Voltage that can be applied between COM and $V_{CCL}$ terminal
High-side Bias Absolute Voltage	$V_{B(U)-COM}$ $V_{B(V)-COM}$ $V_{B(W)-COM}$	-0.5 ~ 670	V	Voltage that can be applied between $V_{B(U)-COM}$ , $V_{B(V)-COM}$ , $V_{B(W)-COM}$ terminal
High-side Bias Voltage for IGBT Gate Driving	$V_{B(U)}$ $V_{B(V)}$ $V_{B(W)}$	-0.5 ~ 20	V	Voltage that can be applied between U- $V_{B(U)}$ , V- $V_{B(V)}$ , W- $V_{B(W)}$ terminal
High-side Bias offset Voltage	$V_U$ $V_V$ $V_W$	-5 ~ 650	V	Voltage that can be applied between U-COM, V-COM, W-COM terminals.
Input Signal Voltage	$V_{IN}$	-0.5 ~ $V_{CCH}+0.5$ -0.5 ~ $V_{CCL}+0.5$	V	Voltage that can be applied between $IN(*)$ -COM terminal
Input Signal Current	$I_{IN}$	3	mA	Maximum input current that flows from $IN(*)$ to COM terminal
Fault Signal Voltage	$V_{FO}$	-0.5 ~ $V_{CCL}+0.5$	V	Voltage that can be applied between COM and $V_{FO}$ terminal
Fault Signal Current	$I_{FO}$	1	mA	Sink current that flows from $V_{FO}$ to COM terminal
Over Current Sensing Input Voltage	$V_{IS}$	-0.5 ~ $V_{CCL}+0.5$	V	Voltage that can be applied between IS and COM terminal
Maximum Junction Temperature of Control Circuit Block	$T_{vj}$	150	$^{\circ}\text{C}$	Maximum junction temperature of the control circuit block
Operating Case Temperature	$T_c$	-40 ~ +125	$^{\circ}\text{C}$	Operating case temperature (temperature of the aluminum plate directly under the IGBT or the FWD)
Storage Temperature	$T_{stg}$	-40 ~ +125	$^{\circ}\text{C}$	Range of ambient temperature for storage or transportation, when there is no electrical load
Isolation Voltage	$V_{isol}$	AC 1500	$V_{rms}$	Maximum effective value of the sine-wave voltage between the terminals and the heat sink, when all terminals are shorted simultaneously. (Sine wave = 60Hz / 1min)
Mounting torque of screws	$M_S$	0.59 ~ 0.98	N·m	Maximum torque value when tightening the product and heat sink with M3 screws.

### <Absolute Maximum Rating of Collector-Emitter Voltage>

During operation, the voltage between P-N(U, V, W) is usually applied to high-side or low-side of one phase. Therefore, Use the product with the voltage applied between P-N(\*) within the absolute maximum ratings. The collector-emitter voltage absolute maximum rating is described below.

$V_{CE(chip)}$ : Since  $V_{CE(chip)}$  cannot be measured directly, use the product with  $V_{DC(terminal)}$ ,  $V_{DC(Surge,terminal)}$ , which is the voltage between P-N(\*) terminals, within the absolute maximum ratings.

$V_{DC(terminal)}$ : DC bus voltage (between P-N(U, V, W) terminals)

$V_{DC(Surge, terminal)}$ : DC bus voltage at P-N(U, V, W) terminals including surge voltage generated during switching.

- Fig.1-7 shows the waveforms during short-circuit, IGBT turn-off and FWD reverse recovery. Since  $V_{DC(Surge,terminal)}$  is different in each situation, it is necessary to set  $V_{DC(terminal)}$  considering these situations.
- $V_{CE(chip)}$  is the collector-emitter voltage absolute maximum rating of the IGBT chip.  $V_{DC(Surge, terminal)}$  is specified considering the margin of surge voltage generated by the wiring inductance inside the Product.
- Also,  $V_{DC(terminal)}$  is specified with margin considering the surge voltage generated by the wiring inductance between the P-N(\*) terminal and the bulk capacitor.

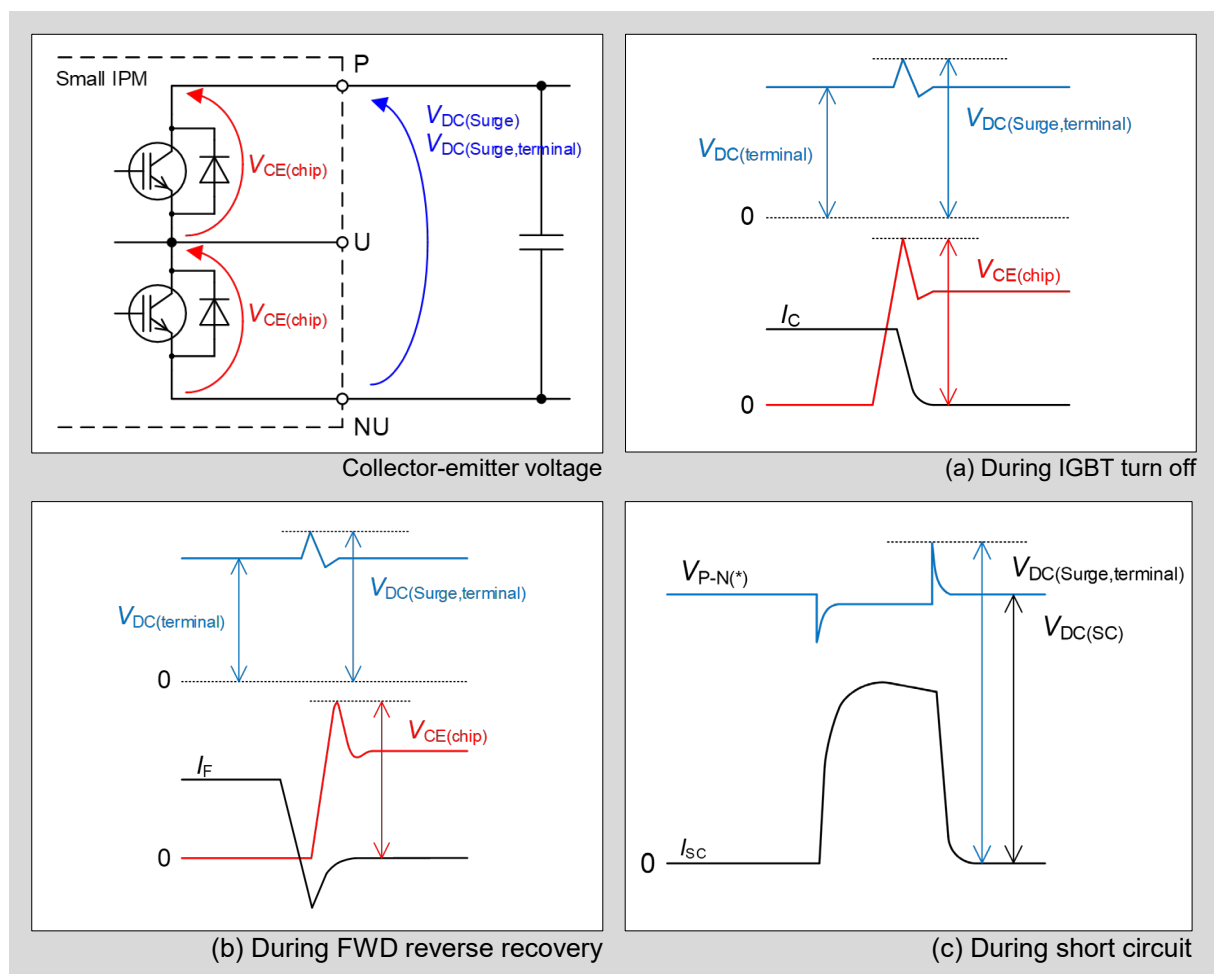

Fig.1-7 Waveforms and Collector-Emitter voltage during IGBT turn-off, FWD reverse recovery, and short-circuit