Mounting Instruction for M404 Package

	Contents	Page
1	Mounting methods of the IGBT module	2
2	Maximum forces and directions for connecting bus bars	4
3	Caution	6

This document describes about recommended mounting procedures for M404 package.

This mounting instruction is available only for the following modules.

4MBIxxxVB-120Rx-xx

4MBIxxxVB-170Rx-xx

4MBIxxxVC-120-5x

(ex. 4MBI900VB-120R1-50)

1 Mounting IGBT modules

This document describes how to mount M404 package.

1.1 Mounting on heat sink

The thermal resistance between IGBT module baseplate and heat sink depends on module location on the heat sink, thermal properties, such as thermal conductivity, of heat sink, and cooling methods. This section, the module location on heat sink is focused and described. Following items should be taken into account in the IGBT module mounting process since thermal resistance will be varied according to the position of the mounted modules:

- ✓ IGBT module(s) should have thermally optimized layout on heat sink according to the mechanical-thermal design so that the modules have good heat spread to minimize the thermal resistance.
- ✓ In case of several IGBT modules to be mounted on the same heat sink, the distance between IGBT modules should be optimized based on the mechanical-thermal design and the estimated total power dissipation of each module in order to avoid the thermal coupling effect between neighbor modules.

1.2 Heat sink surface finishing (module mounting area)

Use this product with keeping the cooling fin's flatness and surface roughness in mounting area with in flatness 50 μ m and surface roughness 10 μ m. If the surface of the heat sink does not have enough flatness, the module may have unexpected increase of the contact thermal resistance ($R_{th(c-f)}$) between the module and the heat sink. Also, if the heat sink flatness doesn't meet the above requirements, a high mechanical stress may be applied to the DCB on the module and it may cause insulation failure.

1.3 Application of thermal grease

Thermal grease between heat sink and module baseplate is absolutely necessary to reduce the contact thermal resistance. Screen-printing, rollers or spatulas are typical method of thermal grease pasting, however, using a stencil mask is recommended when the target grease thickness is less than 100 μ m.

Table 1 Recommended properties of thermal grease

Items	Recommendation
Penetration (typ.)	≥ 338
Thermal conductivity	≥ 0.92 W/mK
Thermal grease thickness	100 μ m \pm 30 μ m

- *1) The thermal resistance between the heat sink and the module depends on the thermal grease properties and thickness. Fuji Electric strongly recommends customers to confirm contact interface after mounting whether the terminal grease spreading is good enough or not. Also Fuji Electric recommends confirmation of the thermal interface status after thermal cycling if the thermal grease has low viscosity.

*2) Electrical document of the recommended stencil mask pattern and recommended method are also available on request.

1.4 Mounting procedure

Mounting procedures onto heat sink are described in below.

(a) The minimum and maximum screw torque for mounting screws (M5) indicated as (1)-(14) in Fig.1 are:

Minimum: 3.0Nm
Maximum: 6.0Nm

(b) Pre-fastening is recommended with 1/3 of the final torque and sequence of (1) – (14) in Fig1.

(c) Final torque must be within specified force of 3.0 to 6.0Nm with sequence of (1) – (14) in Fig1.

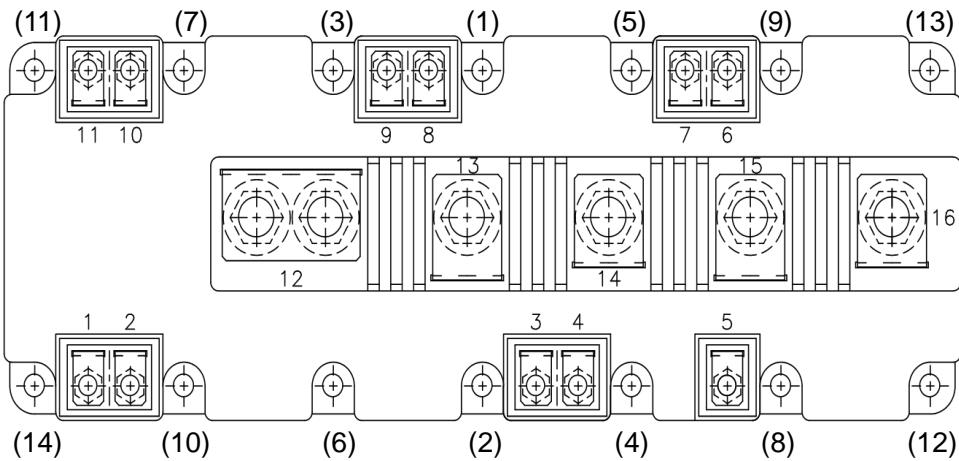

Fig1. Mounting holes connecting sequence (1) – (14) (M404 package)

1.6 Electrostatic discharge (ESD) protection

If excessive static electricity is applied to the control terminals, the devices can be broken. Some countermeasures against static electricity are necessary.

2 Maximum allowable strength and directions for connecting bus bars

Maximum allowable mechanical strength and directions when connecting bus bars to the main and auxiliary terminals are describes in the table below.

Direction	Strength*
A	±100 N
B	±100 N
C	100 N
D	500 N
E	±20 N
F	±20 N
G	50 N
H	200 N

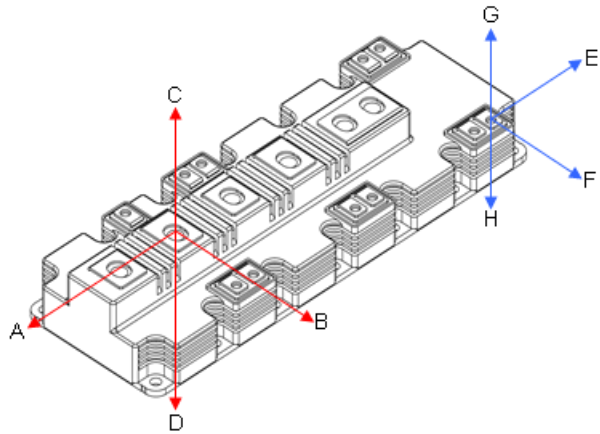

Fig. 2 Maximum allowable strength and directions (M404 package)

*) The strength in the table is a mechanical capability for short period during mounting process

The connection of the auxiliary terminals has to follow the common ESD guidelines. It is not allowed that a load current flow through any of the auxiliary terminals.

We recommend using a support when bus bars are connected to the main terminals as shown in Fig.3. This measure is especially important if the modules or bus bars are subjected to vibration. The mechanical force direction applied to the terminals should be compression force, not tensile force.

Note: It is recommended that the bus bars are attached to the module (main terminals) on compression direction as shown in Fig.3. The maximum stress should be within the values shown in Fig.2

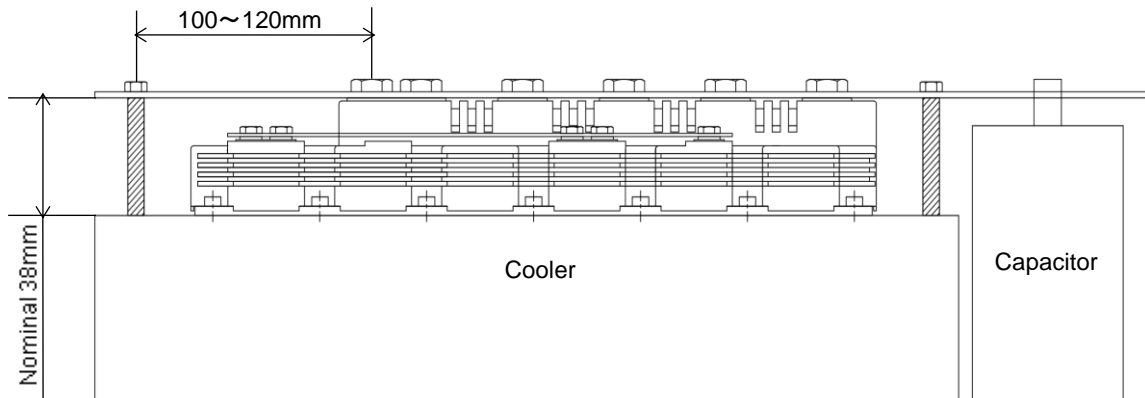

Fig. 3 Example of bus bar configuration without a stress on the module (M404 package)

Screw size and torques:

Mounting holes of base plate: M5, 3 – 6 Nm

Auxiliary terminals: M4, 1.8 – 2.1 Nm

Main terminals: M8, 8 – 10 Nm

Screw length

Max Screw length = 15mm+(Bus bar thickness)+(washer thickness)+(spring washer thickness)

Min Screw Length = 11mm+(Bus bar thickness)+(washer thickness)+(spring washer thickness)

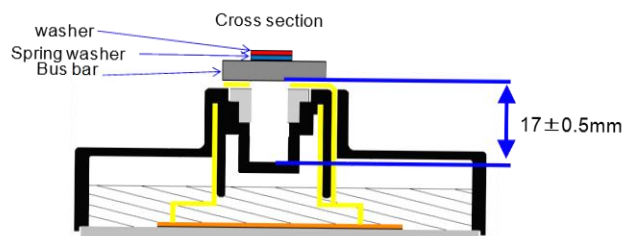

Fig.4 Cross section of main terminal

3 Caution

Don't insert any object in the main terminal screw hole of this product. This screw hole penetrates the case and inner parts of the module (Silicone gel, DCB substrate and chip) are located directly below. Thus, if rod shaped parts like a screwdriver are inserted, there is a possibility that inner parts get damaged significantly. The following describes the position of the through screw hole of M404 package in Fig. 5.

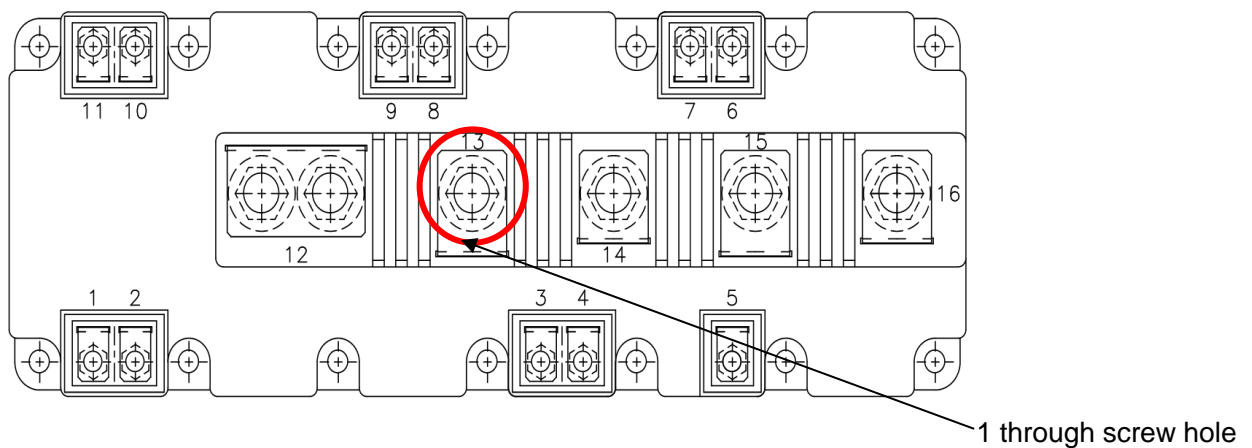

Fig.5 The position of the through screw hole of M404 package

WARNING

1. This Catalog contains the product specifications, characteristics, data, materials, and structures as of May 2017. The contents are subject to change without notice for specification changes or other reason. When using a product listed in this Catalog, be sure to obtain the latest specifications.
2. All applications described in this Catalog exemplify the use of Fuji's products for your reference only. No right or license, either express or implied, under any patent, copyright, trade secret or other intellectual property right owned by Fuji Electric Co., Ltd. is (or shall be deemed) granted. Fuji Electric Co., Ltd. makes no representation or warranty, whether express or implied, relating to the infringement or alleged infringement of other's intellectual property rights which may arise from the use of the applications described herein.
3. Although Fuji Electric Co., Ltd. is enhancing product quality and reliability, a small percentage of semiconductor products may become faulty. When using Fuji Electric semiconductor products in your equipment, you are requested to take adequate safety to prevent the equipment from causing a physical injury, fire, or other problem if any of the products become faulty. It is recommended to make your design failsafe, flame retardant, and free of malfunction.
4. The products introduced in this Catalog are intended for use in the following electronic and electrical equipment which has normal reliability requirements.
 - Computers •OA equipment •Communications equipment (terminal devices) •Measurement equipment
 - Machine tools •Audiovisual equipment •Electrical home appliances •Personal equipment •Industrial robots etc
5. If you need to use a product in this Catalog for equipment requiring higher reliability than normal, such as for the equipment listed below, it is imperative to contact Fuji Electric Co., Ltd. to obtain prior approval. When using these products for such equipment, take adequate measures such as a backup system to prevent the equipment from malfunctioning even if a Fuji's product incorporated in the equipment becomes faulty.
 - Transportation equipment (mounted on cars and ships) •Trunk communications equipment
 - Traffic-signal control equipment •Gas leakage detectors with an auto-shut-off feature
 - Emergency equipment for responding to disasters and anti-burglary devices •Safety devices
 - Medical equipment.
6. Do not use products in this Catalog for the equipment requiring strict reliability such as the following and equivalents to strategic equipment (without limitation).
 - Space equipment •Aeronautic equipment •Nuclear control equipment •Submarine repeater equipment
7. All rights reserved. No part of this Catalog may be reproduced without permission in writing from Fuji Electric Co., Ltd.
8. If you have any question about any portion in this Catalog, ask Fuji Electric Co., Ltd. or its sales agents before using the product. Neither Fuji Electric Co., Ltd. nor its agents shall be liable for any injury caused by any use of the products not in accordance with instructions set forth herein.