Chapter 9

Evaluation and Measurement

CONTENTS		Page
1	Application scope	9-1
2	Evaluation and measurement methods	9-2

This section explains the method of evaluating the IGBT module characteristics and the measurement methods.

1 Application scope

This chapter provides instructions on how to evaluate the characteristics of IGBT modules used in power electronics having a switching frequency of several kHz to 100 kHz and an equipment capacitance of several hundred VA or more. It also provides instructions on how to measure IGBT module voltage and current.

2 Evaluation and measurement methods

2.1 Evaluation and measurement method summary

While power electronic test equipment is always under development, and it is necessary to evaluate the characteristics of a semiconductor device and measure its performance during its installation into circuits, use the correct equipment to capture this information.

Table 9-1 gives a summary description of the evaluation items and measurement methods.

Table 9-1 Evaluation item and measurement method summary.

No.	Evaluation item	Measured quantity	Measurement methods	Measuring equipment
1	Isolation voltage	Voltage	With the module terminals shorted, apply a voltage between the conductive part and the frame of the device.	Isolation voltage tester
2	Collector– Emitter voltage		With the Gate and Emitter shorted, apply test voltage to the Collector and Emitter. *If the applied test voltage exceeds the V rating of components connected to C & E, disconnect those components.	Curve tracer
3	Collector-Emitter saturation voltage		Perform measurements with a voltage clamping circuit inserted between the Collector and Emitter to bypass the effect of the amplifier built in the oscilloscope. *Static characteristics can be measured with a curve tracer or pulse h_{FE} meter.	Oscilloscope
4	Spike voltage		Measure the voltage between the modules terminals directly for both the Collector and Emitter.	Oscilloscope
5	Switching time	Voltage Current	Measure the required voltage and current waveform according to the switching time definition.	Oscilloscope Current probe
6	Current sharing at parallel connection	Current	Measure the current through each device using current transformers for measurement.	Oscilloscope Current probe
7	Switching loss	Voltage Current	The product of the current and voltage is integrated during the switching time. (1) Calculate from the voltage and current waveforms. (2) Use a measuring instrument having math computing capability.	Oscilloscope
8	Operating locus		Plot the current and the voltage during switching action in current-voltage graph.	Oscilloscope with an X-Y display facility
9	Case temperature	Temperature	Measure on the copper base under the IGBT chip. *The case temperature measurement location is shown in chapter 3.	Thermocouple thermometer
10	Junction temperature		Have a calibration curve for the junction temperature and device characteristics created with regard to the temperature dependence of the device characteristics (for example, on resistance) and then measure the characteristics of the device in operation to estimate the junction temperature. *The method of measuring the junction temperature using the IR camera directly.	IR camera

2.2 Voltage measurement

Voltage measurement relates to the measurement of such voltages as the transient voltage during switching action, the voltage in the brief on-state following switching action etc. Note that the accuracy of voltage measurement is affected by the noise interferences imparted from large-amplitude fast switching action.

(1) Measuring apparatus and calibration

Voltages are usually measured using an oscilloscope for the measuring apparatus, because their waveform, as well as the measurement value, is important. Voltage probes are used for voltage measurement.

The time constants of the voltage divider RC of the probe and oscilloscope vary depending on the oscilloscope-probe combination. Before using the probe, carry out probe compensation to achieve uniform attenuation across the frequency range by using the calibrator output and voltage of the oscilloscope.

With an appropriate sensitivity setting (generally, 3 to 4 div amplitude on the display screen), set the input coupling to DC. Exercise caution in selecting the probe, because the adjustment capacitance of the probe and the input capacitance of the oscilloscope must match to enable adjustment.

The selection of oscilloscopes and probes are shown in sections 9-5 and 9-6.

(2) Saturation voltage measurement

Generally, while the circuit voltage under which an IGBT is used comes as high as several hundred Volts, the saturation voltage is as low as several Volts. Because the size of the screen used in an oscilloscope is generally finite, raising the voltage sensitivity in an effort to read the saturation voltage accurately will result in the display of a waveform that is different from the actual waveform, primarily because of the effect of the saturation of the oscilloscope's internal amplifier.

Accordingly, the IGBT saturation voltage during the switching action cannot be known by directly measuring the voltage between the device collector and emitter. Therefore, measure the saturation voltage by adding a voltage clamping circuit shown in Fig.9-1.

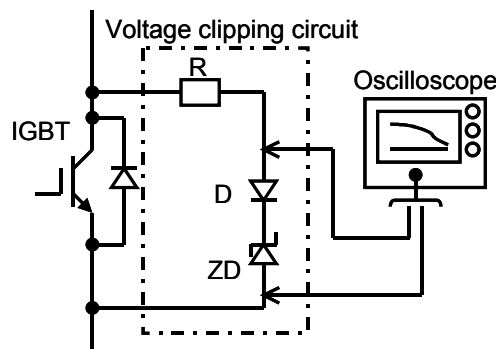

Fig.9-1 Saturation voltage measurement method

In Fig.9-1, the Zener diode (ZD) limits the high voltage when the IGBT is turned-off. Generally, a Zener diode of 10V or less is used. R denotes a current-limiting resistance. Because a large proportion of the circuit voltage is applied to this resistance when the IGBT is turned-off, the resistance must have a relatively large value. The diode (D) prevents the charges built in the junction capacitance of the Zener diode (ZD) from discharging, and also prevents a filter from being formed of the junction capacitance and the current-limiting resistance.

(3) Spike voltage measurement (Collector – emitter voltage measurement)

While IGBTs offer the benefit of fast switching, they have a high ratio of turn-off current change ($-di/dt$), inducing a high voltage in the main circuit wiring inductance (L_s) of the equipment. This voltage is superimposed over the DC circuit voltage to creating a spike voltage to the module. It is necessary to verify that this voltage has a predefined voltage margin, established by the designer, with respect to the maximum voltage ratings.

The spike voltage can be measured at the terminals of the module with an oscilloscope and then directly reading the value on the screen. When making these measurements, keep the following precautions in mind:

- (I) Use a probe and an oscilloscope having a sufficient frequency bandwidth.
- (II) Adjust the oscilloscope sensitivity and calibrate the probe.
- (III) Connect the measurement probe directly to the module terminals.

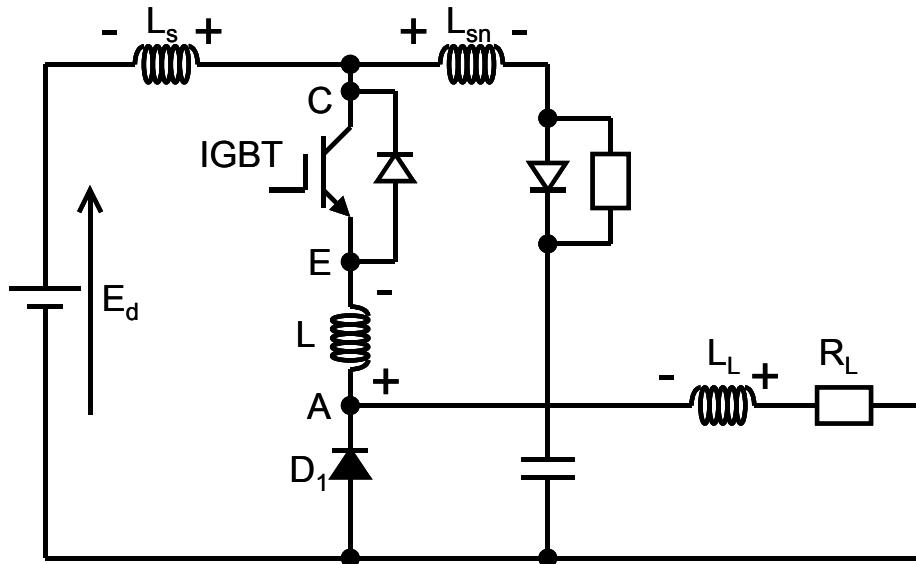

Fig. 9-2 Spike voltage measurement circuit

A voltage of the polarity shown in Fig.9-2 is induced in the circuit inductances during turn-off. Note that in cases where V_{CA} instead of V_{CE} , is measured at this point as an initial voltage, then a voltage lower than V_{CE} by $-L \cdot di/dt$ will be erroneously measured.

- (IV) Keep the probe measurement leads as short as possible.
- (V) Keep probe leads away from high di/dt areas so that noise interferences are not picked up.

If the voltage probe is connected to the circuit under the IGBT, the reference potential of the oscilloscope would equal the switching circuit. If there is a large ground potential variation in the switching circuit, common-mode current would flow through the power line of the oscilloscope, causing its internal circuit to malfunction. Noise interferences can be verified, for example, by:

- (I) Debating whether the standing wave can be logically explained.
- (II) Comparing with wave forms observed on a battery-powered oscilloscope that is less susceptible to noise interferences.

(4) Gate voltage measurement (Gate-emitter voltage measurement)

Although the gate-emitter voltage, like the initial voltage, can be directly measured on an oscilloscope, care should be taken to prevent noise interferences during probe connection and disconnection. This is largely due to the high impedance of the signal source and the gate resistance connected in series with the gate of the IGBT.

The measurement deserves similar attention as in the initial voltage measurement.

2.3 Current measurement

Current probes are used for current measurement. Because practical devices have their main circuitry downsized to cut wiring inductances and simplify their geometry, the wiring needs to be extended to measure the device current. A current transformer can be used to minimize the wiring extension and thus to cut its effect as much as possible. The use of current transformers is also necessary to make up for the limited measuring capacity of the current probe.

A current probe maintains insulation from the conductive part to enable current measurement, but, in addition to being an electromagnetic induction-based detector, it has such a low signal level that it is susceptible to induction-caused noise interferences. Care should be taken, therefore, to guard against noise interferences.

(1) Current detectors

Table 9-2 lists examples of the current detectors.

Table 9-2 Current detectors

No.	Description	Model	Brand	Remarks
1	DC current probe Dedicated amplifier and power supply required	Model A6302	Sony Tektronix	Maximum circuit voltage: 500V Up to 20 A at DC to 50 MHz Up to a peak pulse current of 50A
2		Model A6303		Maximum circuit voltage: 700V Up to 100A at DC to 15MHz Up to a peak pulse current of 500 A
3	AC current probe	Model P6021		Maximum circuit voltage: 600V Up to 15Ap-p at 120Hz to 60MHz, Peak pulse current: 250A
4		Model P6022		Maximum circuit voltage: 600V Up to 6Ap-p at 935Hz to 120MHz Peak pulse current: 100A
5	ACCT	Varied	Pearson	Less than 35MHz
6	AC current probe with a Rogowski coil	CWT	PEM	Current range: 300mA to 300kA Bandwidth: 0.1Hz to 16MHz

(2) Current probe sensitivity check

Before making any measurements, it is necessary to check the probe sensitivity. Use the calibrator output of the oscilloscope or use an oscillator to calibrate the current probe shown in Fig.9-3.

The measurement method of Fig.9-3 uses resistance R (No induced drag is used). Both voltage (e) and R is measured. This voltage (e) is divided by R and current (i) is obtained. These currents are compared with the shape of waves of the current probe and checked for accuracy. If the current (i) is too small, increase primary winding of the current probe.

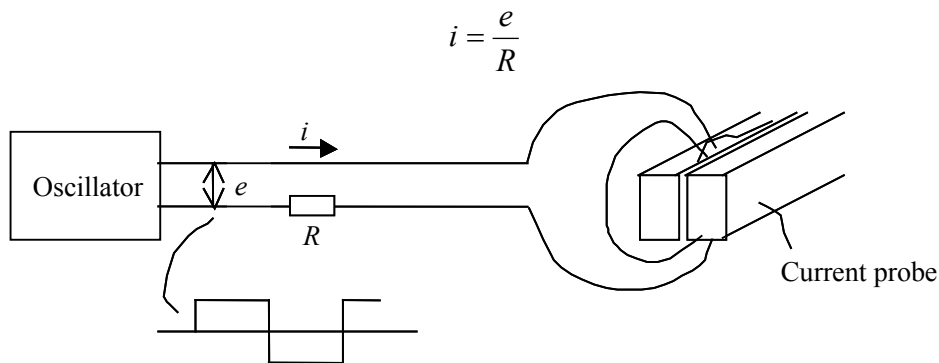

Fig. 9-3 Current probe calibration method

(3) Current measurement method

Fig.9-4 shows where current transformers (CT) are inserted to measure the current through a semiconductor device, and the method of current measurement with two devices connected in parallel.

When the current of T11 on the part of a positive arm is measured, the second side current of CT1 is measured with the current probe. Moreover, the current of T12 measures the side current of the second ditto CT2 with the current probe. The current of the positive side arm (total of the current of the current of T11 and T12) can be measured with the same current probe by measuring in bulk after the direction of the second side current of CT₁ and CT₂ is matched. Please refer to sections 9-6 and 9-7 for the application of the current probe and transducers.

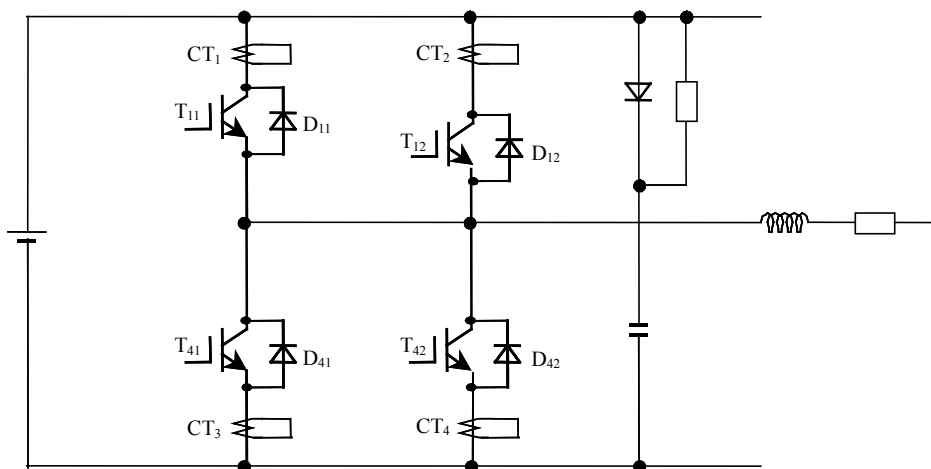

Fig. 9-4 Current measurement method

2.4 Switching loss measurement

The switching loss must be the loss generated between the two instants of time at which switching starts and at which the effect of switching is lost. The turn-on loss, for example, is the loss that is generated after the gate and source are forward-biased until the drain-source voltage reaches the saturation voltage. The switching loss is generally expressed in terms of the energy generated per instance of switching.

Fig.9-5 shows examples of switching waveforms and switching losses. Correct current and voltage waveform measurement is prerequisite to switching loss measurement. Note that when current and voltage are measured simultaneously, the common-mode current flowing from the voltage probe causes the current waveform to be distorted. The presence or absence of a common-mode effect can

be determined by comparing the current waveforms associated with the availability and non-availability of voltage probes. If the current waveform is distorted, insert common-mode chokes (cores with excellent high frequency characteristics having a cable wound on them) into the voltage probe and oscilloscope power cables as shown in Fig.9-6 to alleviate the distortion

Equally important is the settings of reference 0V and 0A. Note that, in current measurement operations using an AC current probe, the position of 0A varies depending on the measurement current value and the conduction ratio.

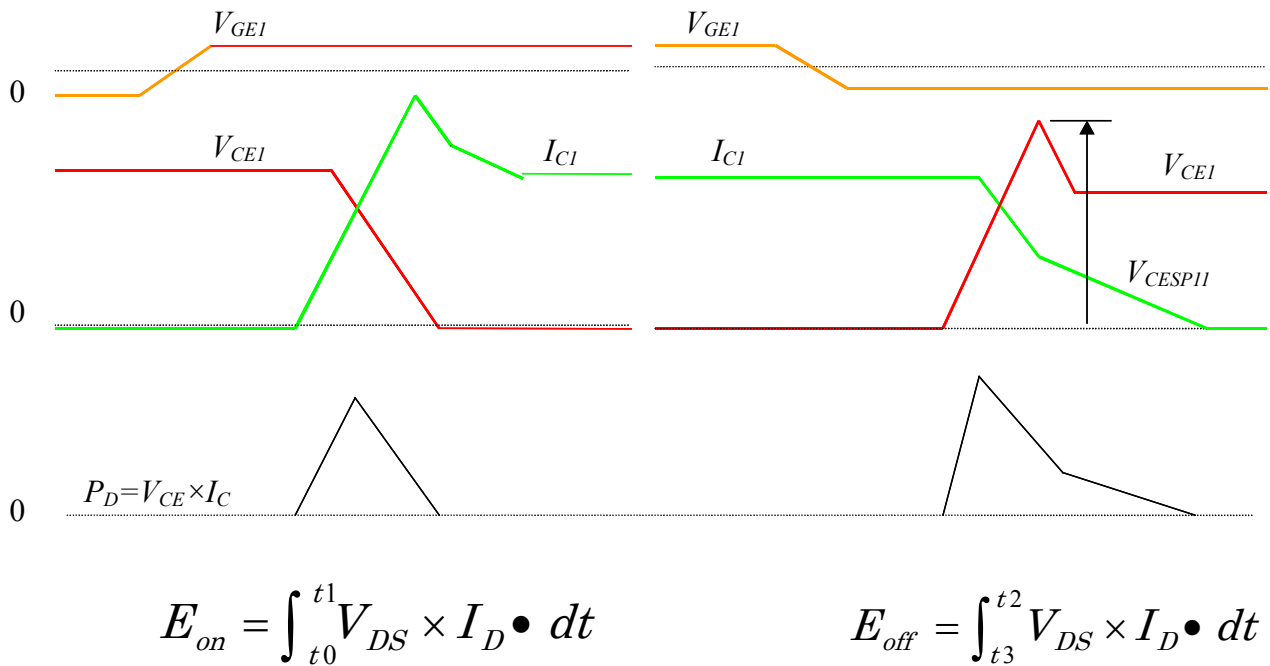

Fig. 9-5 Switching losses

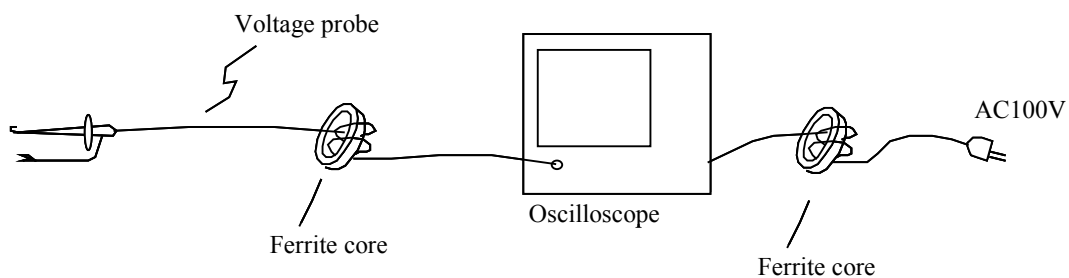

Fig. 9-6 Inserting common mode chokes

2.5 Selecting oscilloscopes

Because oscilloscopes vary in terms of functionality and performance, it is important to select the right oscilloscope to suit the measurement items required and the rate of change in the signal of interest. This section provides a summary description of the signal source rise time and the frequency bandwidth requirements for the oscilloscopes to be used.

(1) Relationship between the rise time of a pulse waveform and the frequency band

The rise time of a pulse waveform is defined as the time needed for the voltage to vary from 10% to 90% as shown in Fig.9-7.

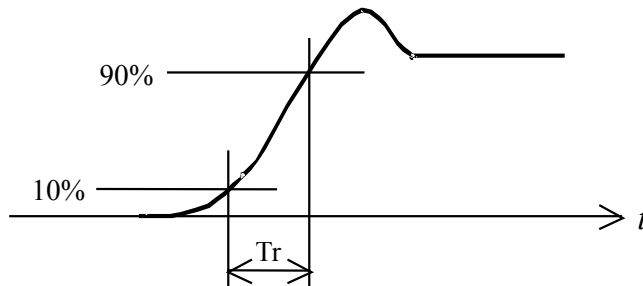

Fig. 9-7 Definition of the rise time of a pulse waveform

Assuming that the rise time is T_r and the frequency at which -3 dB is attained is F_{-3dB} , then the following relationship holds between them:

$$T_r \times F_{-3dB} = 0.35 \dots\dots\dots (1)$$

(2) Signal source rise time (T_{r1}) and oscilloscope selection

Fig.9-8 shows the rise time of each component of an actual system of measurement.

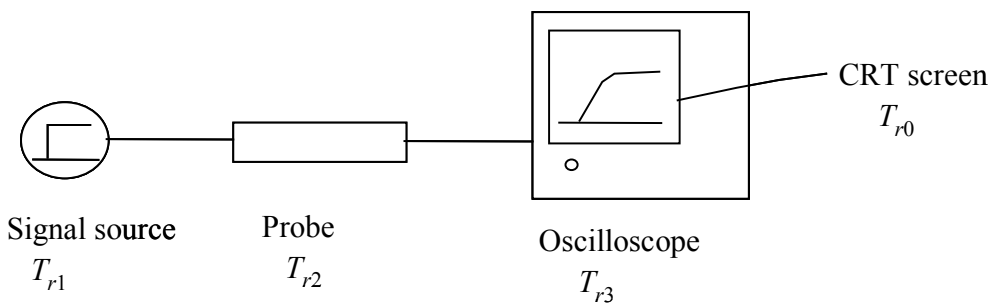

Fig. 9-8 System of measurement and component rise time

The rise time T_{r0} of the waveform displayed on the CRT screen of the oscilloscope is determined by the component rise time and is expressed as:

$$T_{r0} = \sqrt{T_{r1}^2 + T_{r2}^2 + T_{r3}^2} \dots\dots\dots (2)$$

A correct reproduction of the waveform of the signal source is accomplished by setting $T_{r0} = T_{r1}$. Assuming that:

$$\varepsilon = \frac{T_{r0} - T_{r1}}{T_{r1}} \times 100 \text{ (\%)}, \quad k = \frac{T_{r2} + T_{r3}}{T_{r1}} \dots\dots\dots (3)$$

If Eq.(2) is used to determine the relationship between ε and k , it would be as tabulated in Table 9-3.

Table 9-3 Waveform measurement errors, and signal source and measuring apparatus startup time ratios

ε (%)	1	2	3
K	7	5	4

According to these relationships, the sum total of the probe and oscilloscope startup times must not exceed one fourth of the rise time of the signal source. (Exp. $Tr_0 = 3.5\text{ns}$, $\varepsilon = 3\%$, $3.5/4 = 0.87 \text{ ns}$)

If the startup time of the probe is disregarded, solving Eq. (1) gives the required frequency band of the oscilloscope as $0.35/0.87 \times 10^{-9} = 4 \times 10^8$, or 400 MHz. Accordingly, an oscilloscope having a frequency band of 400 MHz or above must be used.

Thus, the selection of the oscilloscope to be used should reflect the rise time of the signal of interest.

2.6 Selecting probes

Probes are available in two types as mentioned earlier: voltage probes and current probes. This section provides basic hints on selecting probes and their usage tips.

2.6.1 Voltage probes

(1) Rise time

It is important to allow for a frequency band for the probe to be used that is in accordance with the rise time of the signal of interest as explained in 9.7. The concept of probe selection is similar to the concept of oscilloscope selection and is not defined here.

(2) Effects of the signal source impedance and probe capacitance on the rise time

An electrical equivalent circuit of the system of measurement is shown in Fig.9-9, in which R_1 and C_1 denote the output impedance and capacitance of the signal source, respectively, and R_2 and C_2 denote the input impedance and capacitance of the oscilloscope, respectively.

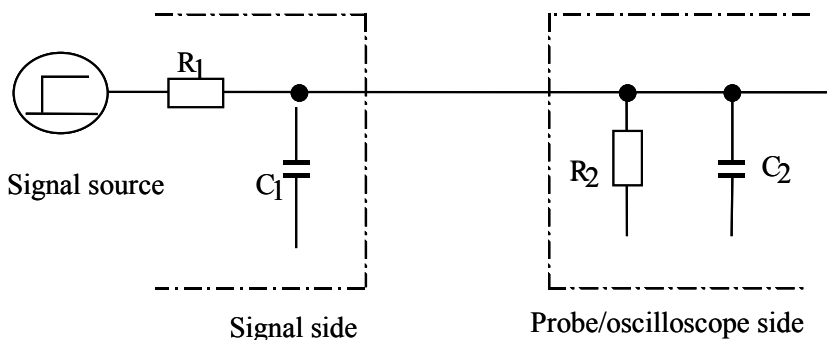

Fig. 9-9 Electrical equivalent circuit of the system of measurement

The rise time Tr of the C-R filter can be expressed by:

$$T_r = 2.2 \times R \times C$$

In Fig.9-9, R and C can be expressed in equations as:

$$R = \frac{R_1 \times R_2}{R_1 + R_2} \quad C = C_1 + C_2$$

The following facts become apparent from these relationships:

- 1) The higher the output impedance of the signal source, the longer the rise time becomes.
- 2) This also holds true with probes or oscilloscopes having a large capacitance:

- ① For example, if the signal of a signal source ($R_1 = 500\Omega$, $C_1 = 2 \text{ pF}$) is measured using an ordinary passive 10:1 probe ($C_2 = 9.5 \text{ pF}$, $R_2 = 10 \text{ M}\Omega$), a rise time of 12ns, would result from the connection of the probe, compared with 2.2 ns without its connection, generating a significant error.

(3) Probe selection

Table 9-4 summarizes the conditions for selecting probes to suit specific measurement objectives and tips on measurement using these probes.

Table 9-4 Conditions for selecting probes to suit specific objectives of measurement

Measurement Item	Amplitude measurement	Rise time	Phase difference
Probe requirements	The input impedance must be high in the working frequency band.	A sufficient frequency band is available for the rise time of the signal source.	Low input capacitance Matched cable lengths and characteristics
Directions	The pulse width is at least five times the time constant of the probes and the oscilloscope. Select a signal source of the lowest impedance possible.	The pulse width is at least five times the time constant of the probes and the oscilloscope. Select a signal source of the lowest impedance possible.	Measure the probe-to-probe time difference beforehand. *A 3.5-foot probe has a delay of 5 ns.

(4) Directions

Correct signal measurement requires an understanding of the characteristics of probes to make a correct choice. Key items to consider when selecting a probe are listed below.

- a. Does the probe have the current range to measure the desired target voltage/current.
- b. Is the frequency bandwidth of the probe correct for the measurement?
- c. Is the maximum input (withstand voltage) adequate?
- d. Will the loading effect of the probe cause a false reading? (optimal measuring points)
- e. Is the ground (earth wire) connected properly?
- f. Are there mechanical or physical strains?

In measuring fast switching pulses, grounding should be checked carefully. In this case, resonance could arise from the inductance of the ground lead and the probe capacitance. Such resonance would be particularly pronounced in a broadband oscilloscope. Shortening the probe ground lead to ground and the tip can reduce resonance or oscillation. An adapter usually comes with each voltage probe as an accessory for this purpose.

In addition, a ground lead may be connected to each individual probe to guard against induction-caused noise interferences shown in Fig. 9-10. The points to which the ground leads are connected must have equal potentials in this case.

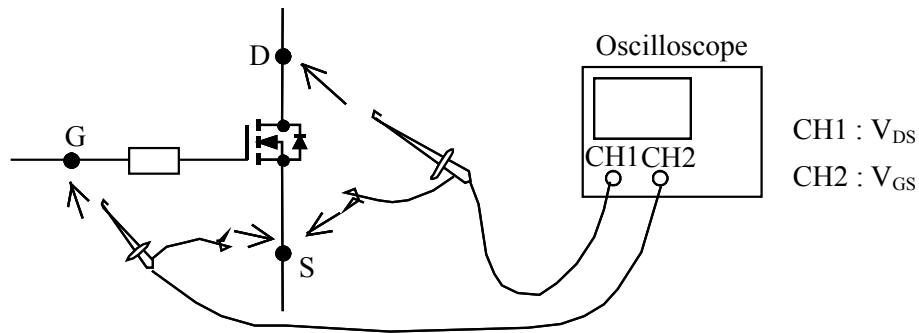

Fig. 9-10 Connecting voltage probes

2.6.2 Current probes

The types of current probes available are as described in 2.3. This section focuses on tips on using current probes in actual applications.

(1) Current probe selection

Current probes are available in two types as mentioned earlier: DC current probes and AC current probes. AC current probes, with their better noise immunity, are recommended for use in measuring current waveforms during fast switching action.

If a DC or low-frequency AC current is introduced through an AC current probe, the core in the probe would be saturated to suppress output. To measure the switching action of an IGBT used in a circuit that deals with a DC or low-frequency AC, some techniques are necessary, such as fabricating and using a timing control circuit to simulate the actual action.

(2) Use precautions

- A ferrite core is housed in the tip of a current probe. The ferrite core is extremely vulnerable to impact and must be protected against dropping.
- Be careful not to exceed the ratings.
 - Withstand voltage: If the circuit voltage is high, cover the measuring point with a voltage-resistant tube.
 - A-S (current product): Pulse current rating. Excessive current flow could cause damage to the probe.
 - Maximum RMS current immunity: Limited by the power capacitance of the secondary circuit in the probe transformer. The probe could be burned if this limit is exceeded.
- With a voltage clamping circuit, perform measurement with the current probe being securely clipped to the circuit.
- Do not release the secondary side of the circuit with the current probe clipped to the circuit. (Without a terminator in position, a high voltage could be generated on the secondary side.)
- Insertion impedance

Inserting the probe into position generates an insertion impedance on the primary side of the circuit. It is important to ensure that the insertion impedance does not affect the measuring object. Assuming that the probe is an ideal transformer, the insertion impedance can be expressed in Fig.9-1.

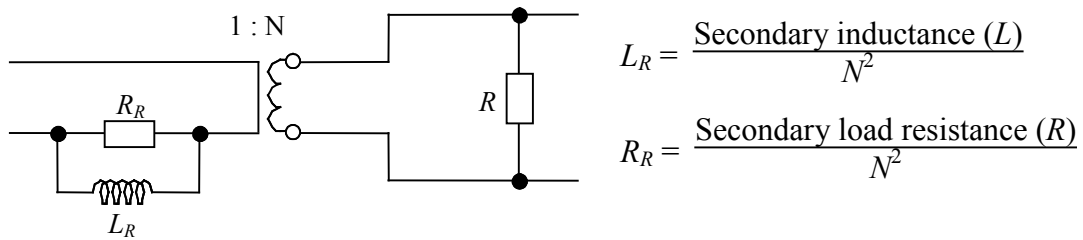

Fig. 9-11 Probe insertion impedance

2.7 Using current transformers

A current transformer is used to ease the constraint on the working range of a current probe and to minimize the effects partial modifications made to measurement purposes may have upon circuit performance. For information on the locations where current transformers are inserted and instructions on how to measure current, see Fig. 9.3.

Assuming that the number of turns (secondary) of the transformer is N , and the primary current is I_1 and the secondary current is I_2 , an ideal transformer would meet the relationship $I_2 = I_1/N$. With the excitation current taken into account, the relationship can be rewritten as:

$$I_0 = I_1 - N \times I_2$$

The excitation current must be a small value because it creates a measurement error. Check the value of N with regard to the transformer, measure I_1 and I_2 and calculate I_0 from the equation above to make sure that the measurement accuracy is acceptable.

Next, check the direction of the current flow. Current flows through the secondary winding in such direction that a magnetic flux generated in the core by the primary current is canceled.

Be careful not to drop the ferrite core because it could be damaged.

WARNING

1. This Catalog contains the product specifications, characteristics, data, materials, and structures as of January 2017. The contents are subject to change without notice for specification changes or other reasons. When using a product listed in this Catalog, be sure to obtain the latest specifications.
2. All applications described in this Catalog exemplify the use of Fuji's products for your reference only. No right or license, either express or implied, under any patent, copyright, trade secret or other intellectual property right owned by Fuji Electric Co., Ltd. is (or shall be deemed) granted. Fuji Electric Co., Ltd. makes no representation or warranty, whether express or implied, relating to the infringement or alleged infringement of other's intellectual property rights which may arise from the use of the applications described herein.
3. Although Fuji Electric Co., Ltd. is enhancing product quality and reliability, a small percentage of semiconductor products may become faulty. When using Fuji Electric semiconductor products in your equipment, you are requested to take adequate safety measures to prevent the equipment from causing a physical injury, fire, or other problem if any of the products become faulty. It is recommended to make your design failsafe, flame retardant, and free of malfunction.
4. The products introduced in this Catalog are intended for use in the following electronic and electrical equipment which has normal reliability requirements.
 - Computers
 - OA equipment
 - Communications equipment (terminal devices)
 - Measurement equipment
 - Machine tools
 - Audiovisual equipment
 - Electrical home appliances
 - Personal equipment
 - Industrial robots etc.
5. If you need to use a product in this Catalog for equipment requiring higher reliability than normal, such as for the equipment listed below, it is imperative to contact Fuji Electric Co., Ltd. to obtain prior approval. When using these products for such equipment, take adequate measures such as a backup system to prevent the equipment from malfunctioning even if a Fuji's product incorporated in the equipment becomes faulty.
 - Transportation equipment (mounted on cars and ships)
 - Trunk communications equipment
 - Traffic-signal control equipment
 - Gas leakage detectors with an auto-shut-off feature
 - Emergency equipment for responding to disasters and anti-burglary devices
 - Safety devices
 - Medical equipment
6. Do not use products in this Catalog for the equipment requiring strict reliability such as the following and equivalents to strategic equipment (without limitation).
 - Space equipment
 - Aeronautic equipment
 - Nuclear control equipment
 - Submarine repeater equipment
7. Copyright ©1996-2011 by Fuji Electric Co., Ltd. All rights reserved.
No part of this Catalog may be reproduced in any form or by any means without the express permission of Fuji Electric Co., Ltd.
8. If you have any question about any portion in this Catalog, ask Fuji Electric Co., Ltd. or its sales agents before using the product. Neither Fuji Electric Co., Ltd. nor its agents shall be liable for any injury caused by any use of the products not in accordance with instructions set forth herein.