

Large-scale Photovoltaic Power Generation Systems

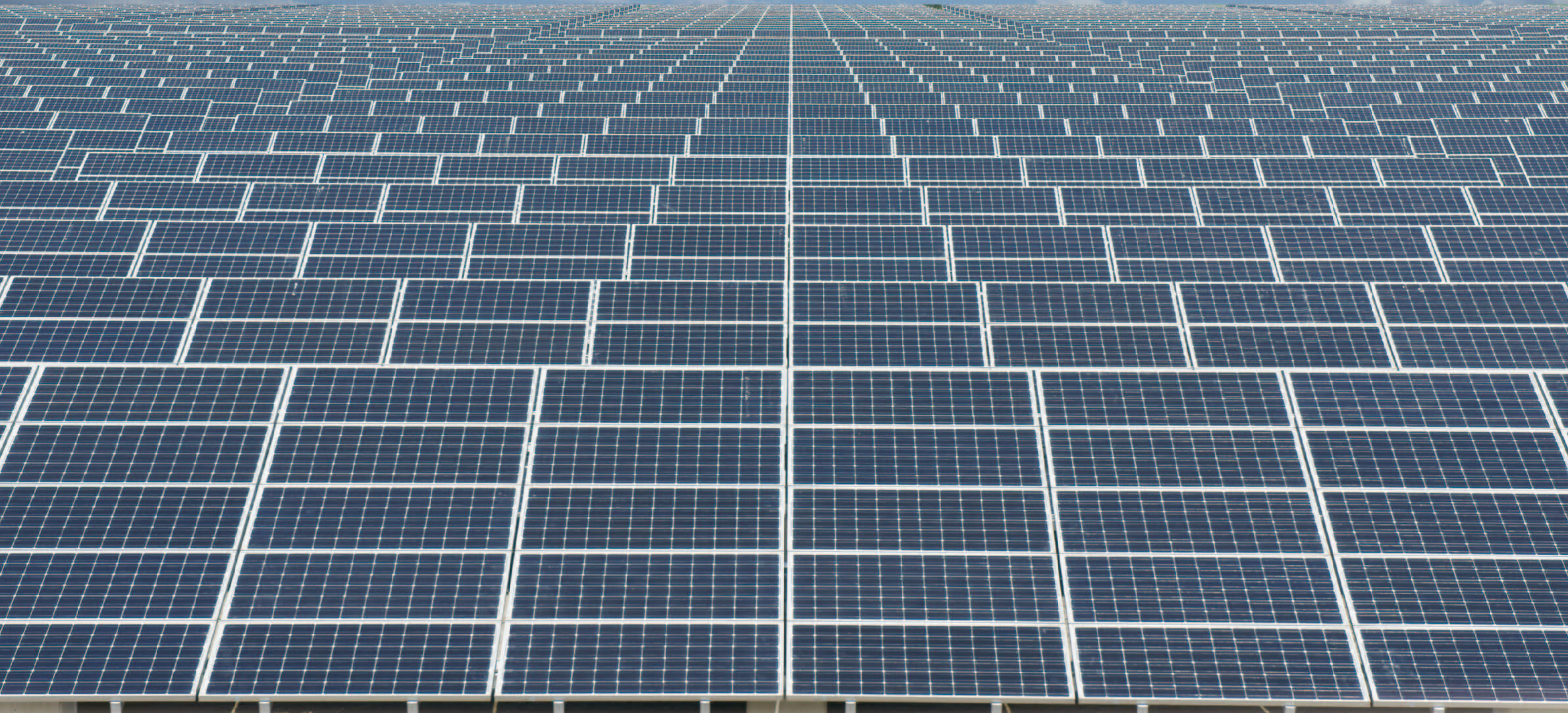

Our photovoltaic power generation systems provide eco-friendly energy.



■ Maximizing Output Power from Photovoltaic Power Generation

High-efficiency three-level inverter with our original RB-IGBT

At Fuji Electric we develop and manufacture high-efficiency power conditioner systems (PCS) in-company using our unique proprietary reverse-blocking insulated gate bipolar transistor (RB-IGBT) technology. Our power conditioners, which are at the industry's highest level and use the maximum power point tracking control (MPPT) that we have refined through long development, enable maximum output power from photovoltaic power generation.

■ Total System Construction from PCS to System Interconnection

Fuji Electric offers a wide product lineup from high-voltage and extra-high-voltage interconnection facilities that we have developed as a heavy electrical equipment manufacturer to supply-and-demand monitoring and PCS units. We support total system introduction of photovoltaic power generation facilities for our customers.

■ System Stabilization Technology

Power stabilizers, private power generators, and hybrid power supplies such as wind power generation and fuel cells

Fuji Electric has developed its system stabilization technology for more than 20 years.

We make use of various types of power supply equipment such as private power generators and wind power generators and power accumulation technology developed for UPS to supply stable power by combining power supply types tailored to each region.

■ Secure Support System in Japan and Abroad

Our service engineers provide secure maintenance support for customer facilities from Hokkaido to Okinawa in Japan and at international service locations.

Total Engineering Solutions from System Planning to Maintenance

Fuji Electric is a full-service equipment manufacturer, a peripheral equipment supplier, and a total engineering solution provider of photovoltaic power generation systems from system design to construction management.

Fuji Electric System Solutions

Fuji Electric provides photovoltaic power generation systems optimized for each region by combining our in-depth experience and advanced technologies.

- Long history of accomplishments and experience since foundation in 1923 (Solar cell characteristics, inverter technology, and system interconnection technology)
- Advanced technologies (RB-IGBT and system interconnection technology)

● **High efficiency** (98.5% for DC 1,000 V specifications)

● **Series expanded to DC 600 V specifications**

● **Substation configuration for easy construction***

PCS (Power conditioner system)



*: Integrated configuration includes power conditioner system (PCS), switchgear, and step-up transformer.

Transformation system



- System interconnection technology
- Smart grid monitoring technology
- Large-scale plant technology

● System-matched Modules



PV module

● Overseas and Japanese power generation operators (public and private sector)



Sales and after-sales service

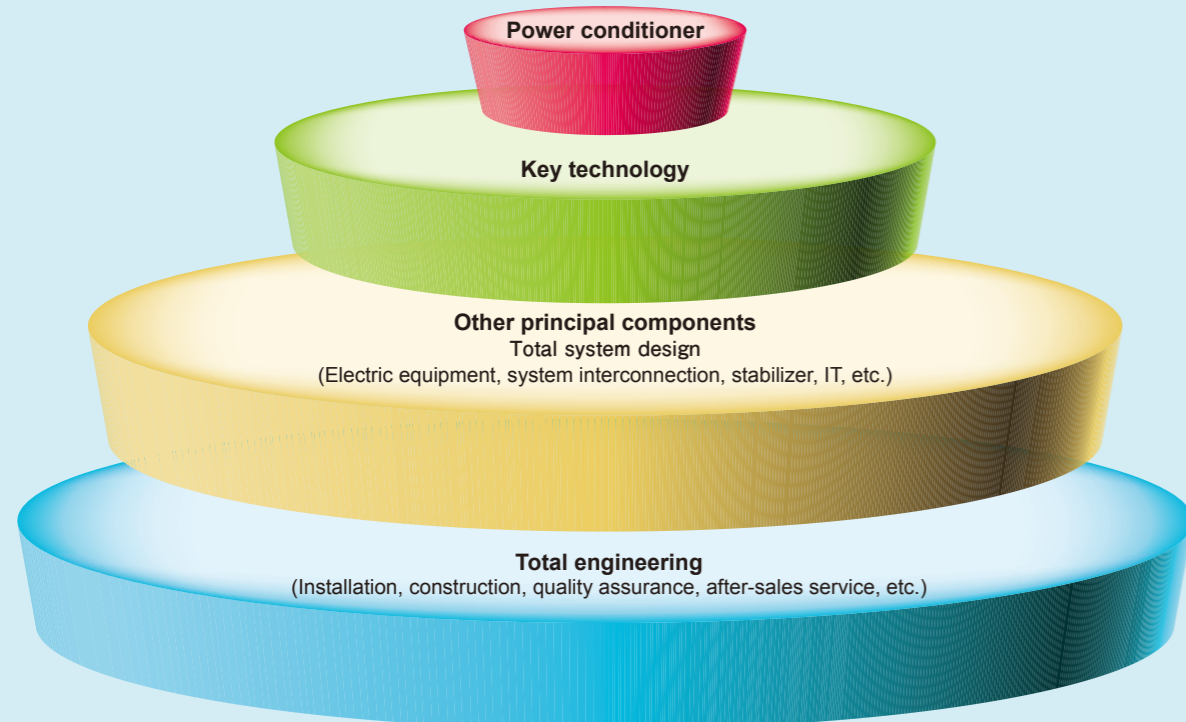

Fuji Electric provides comprehensive system proposals for efficient operation from solar cells to power transmission.

One-line Diagram

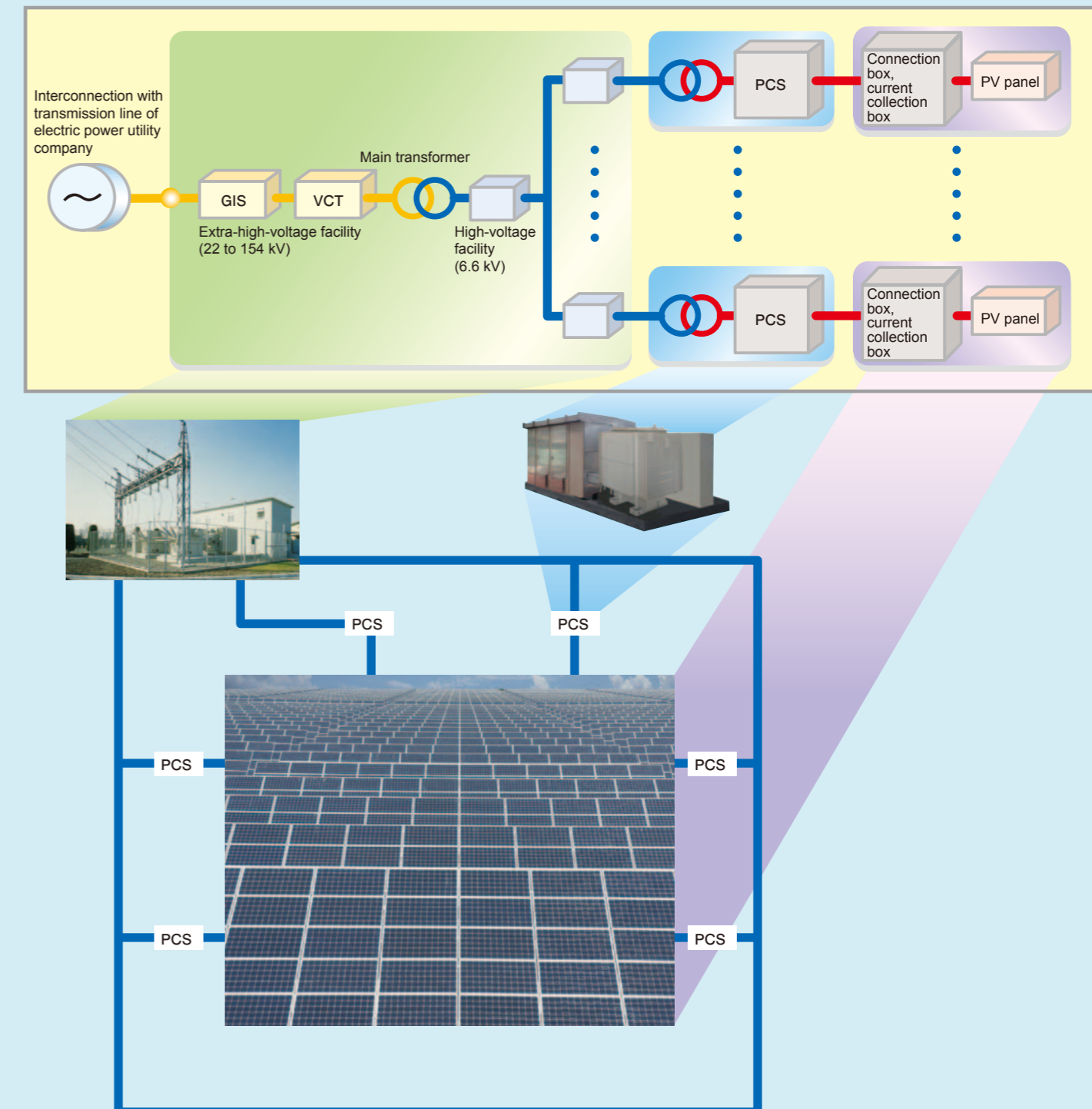

As the PCS is the core of the system, we provide a large-capacity PCS of the highest efficiency that incorporates advanced power semiconductors.

(The series lineup was reinforced with the addition of a new 500 kW model.)

Features

Adoption of new IGBT and new circuit system

Fuji Electric commercialized the world's first three-level module in which a new RB-IGBT* and an existing IGBT are integrated in one package.

Application of this new module to a new three-level conversion circuit enables a large reduction both in power loss and in the number of parts, resulting in high efficiency and low noise in the equipment.

*: RB-IGBT: Reverse Blocking-Insulated Gate-Bipolar Transistor

New IGBT module

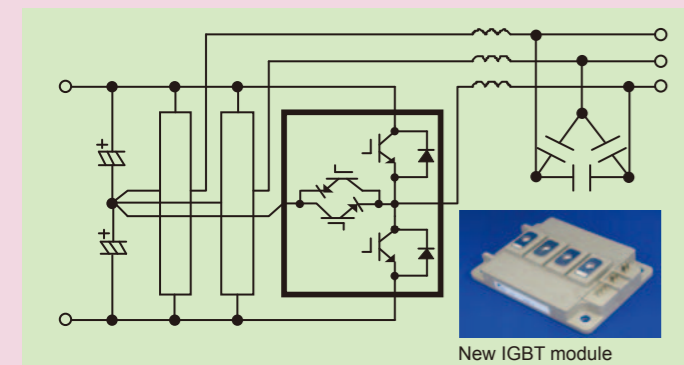

New three-level conversion circuit

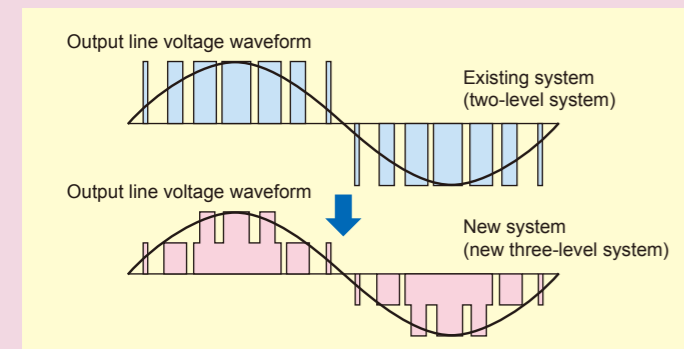

Reduction of power loss

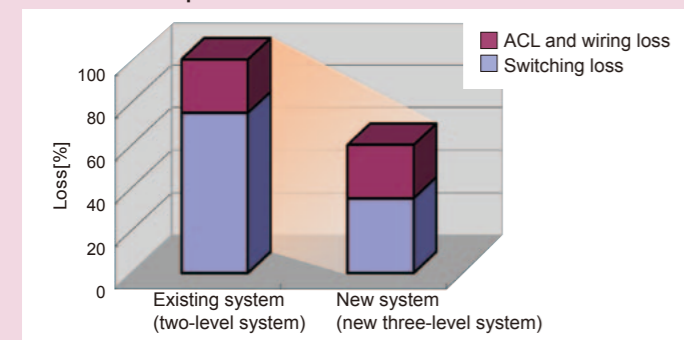

World's highest efficiency 98.5% (DC 1,000 V product)

Compared to existing products, our new power conversion technology, which uses a new three-level conversion circuit in the new module, reduces switching loss in the IGBT device and also reduces filter loss by reducing to one half the harmonic content in PWM waveform outputted by the inverter. This results in the world highest efficiency of 98.5% (DC 1,000 V product). We have also achieved EURO efficiency of 98.2% (DC 1,000 V product).

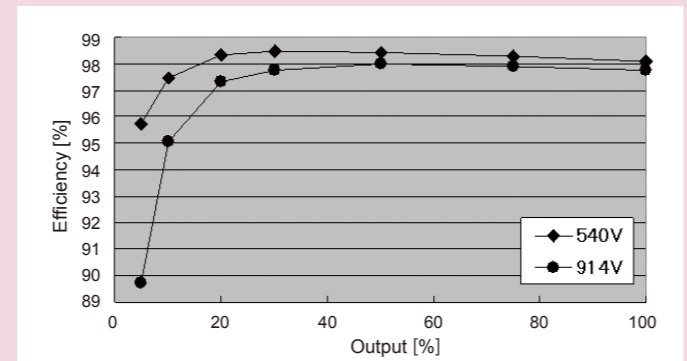

Note: Internal power supply is not included. IEC61683 efficiency tolerance is indicated.

Outdoor substation type

Fuji Electric provides a substation type of PCS that can be installed outdoors.

A switchgear, a step-up transformer, and PCS that can be installed outdoors are integrated on a common base in a single unit. This eliminates the need for a building for storing panels and air-conditioning facilities. Since this substation is transported to the site as an integrated unit, on-site construction costs can be greatly reduced.

With the installation of an optional fuse for a DC branch in the PCS, the panel output collected in the current collection box can be connected to the PCS as is.

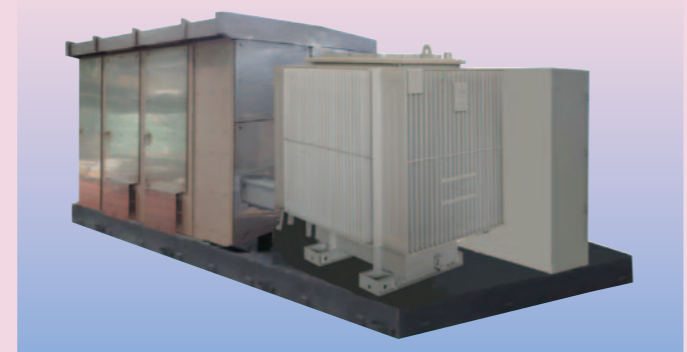

Single unit capacity 1,000 kW

Fuji Electric successfully developed a PCS with a single unit capacity of 1,000 kW.

For large-scale photovoltaic power generation systems, this large single unit capacity enables the number of PCS units to

be optimized, resulting in significant reductions in construction and building costs.

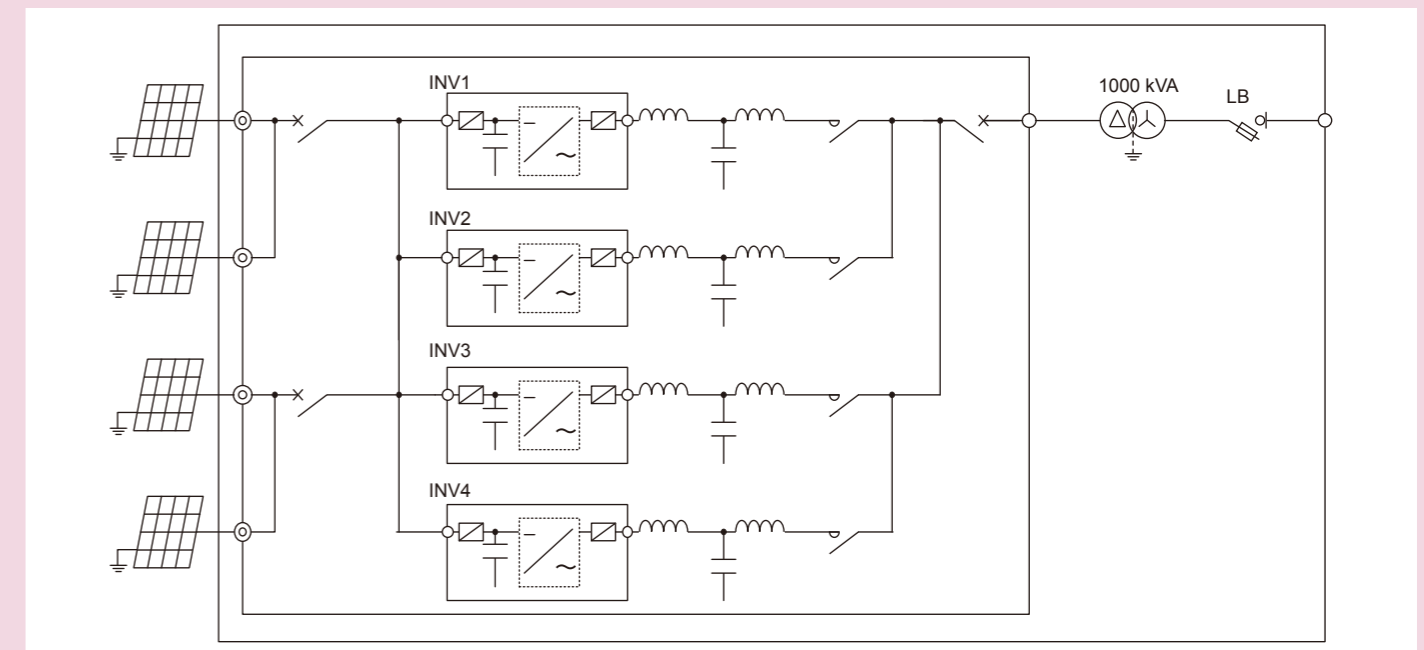

Standard FRT function

The fault ride through (FRT) function that is becoming essential in PCS for large-scale photovoltaic power generation is provided as a standard function. Even if a three-phase or two-phase short circuit accident

occurs in the system, the inverter can output three-phase current in a specified range to suppress power supply variations in the system.

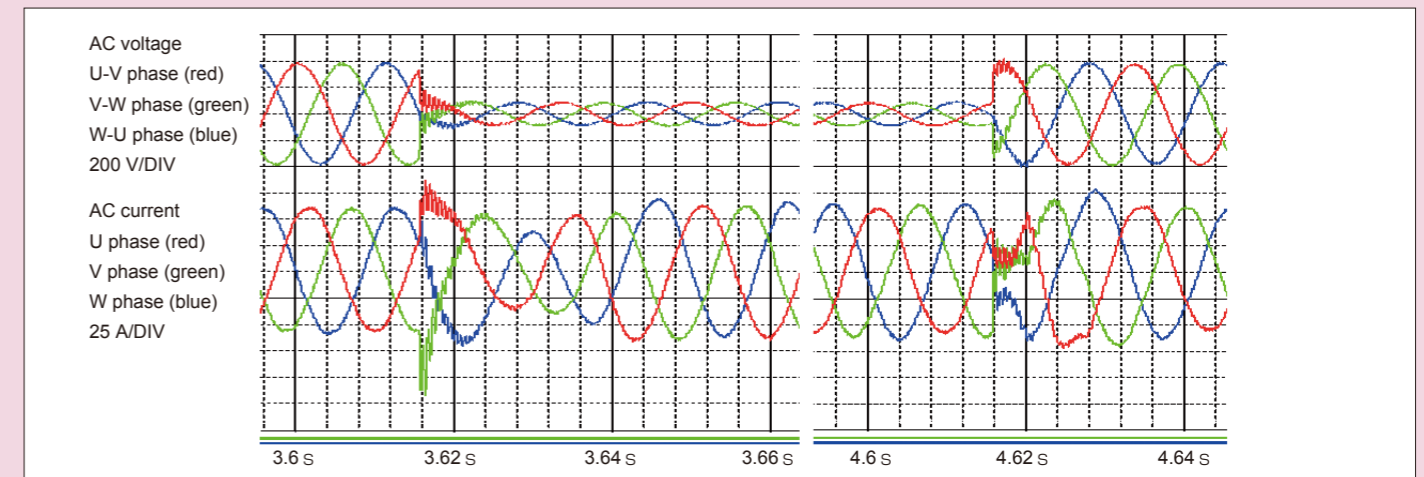

Specifications

Example of appearance



Operation screen

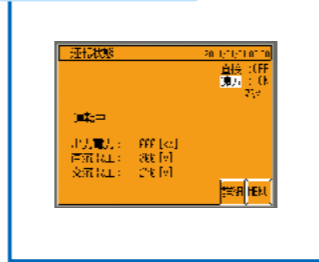

Example of outside dimensions

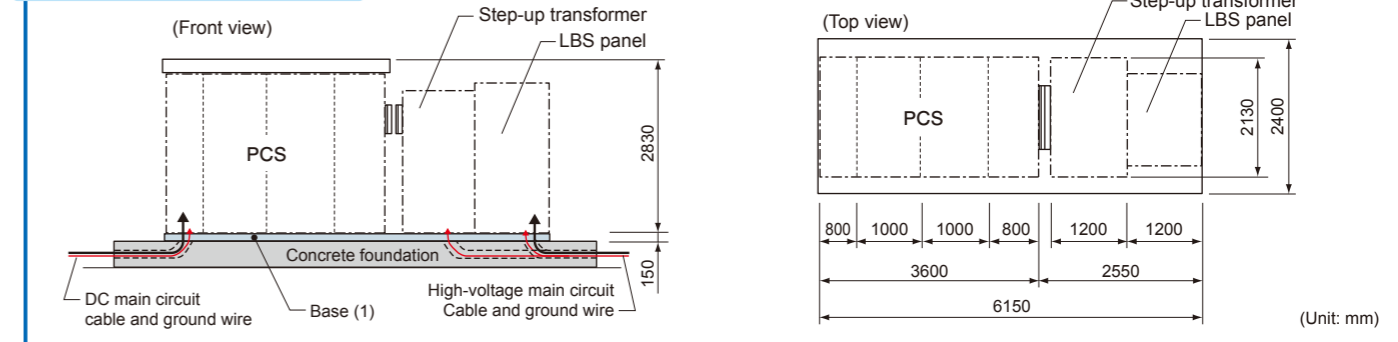

PCS (DC 1000 V) specifications (Outdoor self-standing type)

Item	Series name	PVI1000-3/1000	Remarks		
	Rated output	1000 kW			
	Insulation system	Transformerless system			
	DC input voltage range	1000 V			
Electric specifications (DC input)	DC input voltage (MPPT range)	460 V to 950 V	24 branches (Option)		
	Number of DC input branches	4			
	Rated output capacity	1000 kW			
Electric specifications (AC output)	Rated output voltage	270 V -10 % to +12 %	Individual operation Q output excluded (when output is 1/8 of rated output).		
	Rated frequency	50/60 Hz ±5 %			
	Number of output phases	Three-phase, three-wire; isolated neutral system supported.			
	Rated output current	2138 A			
	Output power factor	>0.99(at rated output)			
	Output current distortion factor (total)	<5 % (at rated output)			
	Output current distortion factor (each)	<3 % (at rated output)			
	Equipment highest efficiency	98.5 %			
	Equipment efficiency (Euro efficiency)	98.2 %			
	Overload capacity	100 % continuous			
	Noise	85 dB			
	System interconnection	System protection		OV, UV, OF, UF	Based on the country's grid code.
		Individual operation detection system (passive)		Detection of voltage phase jump	
Individual operation detection system (active)		Reactive power variation system			
Voltage rise suppression function		Reactive current compensation, active current output suppression			
FRT		Vmin=15 %, 0.625 S Recovery time 3 s			
Panel structure	Installation system	Outdoor self-standing type	Measures against salt damage are optional.		
	Applicable IP	IP54			
	System type	Substation system			
	Cable lead-in	Lower part			
Dimensions	PCS single unit (W × D × H)	3600×2130×2830 mm	Integrated step-up transformer and switchgear		
	Substation (W × D × H)	6150×2400×2830 mm			
Mass	PCS single unit	About 7000 kg			
	Substation	About 12500 kg			
Environmental conditions	Storage temperature	-20 °C to +50 °C	High-temperature option available for +50 °C. Non-condensing		
	Operating temperature	-10 °C to +40 °C			
	Relative humidity	15 to 95 %			
	Altitude	2000 m or less			
Relevant standard	IEC62109-1				
Communication system	RS-485/MOD BUS/TCP				

Switchgear and step-up transformer (1000 kW) specifications

Item	Rated output	1000 kW	Remarks
Electric specifications of switchgear	Power supply voltage	4.16 to 34.5 kV	Values other than the left value are optional.
	Power supply frequency	50/60 Hz	
	Number of power supply phases	Three-phase, three-wire	
	Rated current	200 A	
	Breaking capacity	12.5 kA	
Electric specifications of step-up transformer	Capacity	1000 kVA	
	Number of phases	Three-phase	
	Frequency	50/60 Hz	
	Cooling system	Oil-immersed self-cooling	
	Connection system	Y-Δ	
	Others	Contact prevention plate is provided.	

PCS (DC 750 V) specifications (Outdoor self-standing type)

Item	Series name	PVI750-3/750	Remarks		
	Rated output	750kW			
	Insulation system	Transformerless system			
	DC input voltage range	750 V			
Electric specifications (DC input)	DC input voltage (MPPT range)	320 V to 750 V	16 branches (Option)		
	Number of DC input branches	4			
	Rated output capacity	750 kW			
Electric specifications (AC output)	Rated output voltage	200 V -10 % to +12 %	Individual operation Q output excluded (when output is 1/8 of rated output).		
	Rated frequency	50/60 Hz ±5 %			
	Number of output phases	Three-phase, three-wire; isolated neutral system supported.			
	Rated output current	2165 A			
	Output power factor	>0.99(at rated output)			
	Output current distortion factor (total)	<5 % (at rated output)			
	Output current distortion factor (each)	<3 % (at rated output)			
	Equipment highest efficiency	97.8 %			
	Equipment efficiency (Euro efficiency)	97.4 %			
	Overload capacity	100 % continuous			
	Noise	85 dB			
	System interconnection	System protection		OV, UV, OF, UF	Based on the country's grid code
		Individual operation detection system (passive)		Detection of voltage phase jump	
Individual operation detection system (active)		Reactive power variation system			
Voltage rise suppression function		Reactive current compensation, active current output suppression			
FRT		JEAC9701-2010 (conforms to supplementary version of 2011)			
Panel structure	Installation system	Outdoor self-standing type	Measures against salt damage are optional.		
	Applicable IP	IP54			
	System type	Substation system			
	Cable lead-in	Lower part			
Dimensions	PCS single unit (W × D × H)	3600×2130×2830 mm	Integrated step-up transformer and switchgear.		
	Substation (W × D × H)	6150×2400×2830 mm			
Mass	PCS single unit	About 7000 kg			
	Substation	About 12500 kg			
Environmental conditions	Storage temperature	-20 °C to +50 °C	High-temperature option available for +50 °C. Non-condensing		
	Operating temperature	-10 °C to +40 °C			
	Relative humidity	15 to 95 %			
	Altitude	2000 m or less			
Relevant standard	JIS, JEM, JEC				
Communication system	RS-485/MOD BUS/TCP				

Switchgear and step-up transformer (750kW) specifications

Item	Rated output	750 kW	Remarks
Electric specifications of switchgear	Power supply voltage	6.6 kV	Values other than the left value are optional.
	Power supply frequency	50/60 Hz	
	Number of power supply phases	Three-phase, three-wire	
	Rated current	200 A	
	Breaking capacity	12.5 kA	
Electric specifications of step-up transformer	Capacity	750 kVA	
	Number of phases	Three-phase	
	Frequency	50/60 Hz	
	Cooling system	Oil-immersed self-cooling	
	Connection system	Y-Δ	
	Others	Contact prevention plate is provided.	

PCS optional



■ PCS (DC 750 V) specifications (Indoor self-standing type)

Item	Series name	PVI750-3/500	Remarks	
	Rated output	500kW		
	Insulation system	Transformerless system		
	DC input voltage range	750V		
Electric specifications (DC input)	DC input voltage (MPPT range)	320V to 700V		
	Number of DC input branches	5		
				Optional
Electric specifications (AC output)	Rated output capacity	500kW		
	Rated output voltage	200V -10% to +12%		
	Rated frequency	50/60Hz		
	Number of output phases	Three-phase, three-wire; isolated neutral system supported.		
	Rated output current	1444A		
	Output power factor	>0.99 (at rated output)		Individual operation Q output excluded
	Output current distortion factor (total)	<5% (at rated output)		
	Output current distortion factor (each)	<3% (at rated output)		
	Equipment highest efficiency	97.7%		
	Equipment efficiency (Euro efficiency)	97.3%		
	Overload capacity	100% continuous		
Noise	75dB or less			
System interconnection	System protection	OV, UV, OF, UF		
	Individual operation detection system (passive)	Detection of voltage phase jump		
	Individual operation detection system (active)	Reactive power variation system		
	Voltage rise suppression function	Reactive current compensation, active current output suppression		
Panel structure	FRT	V _{min} =15%, 0.625s Recovery time 3 s	Based on the country's grid code	
	Installation system	Outdoor self-standing type		
	Applicable IP	—		
	System type	—		
	Cable lead-in	Lower part		
Cooling system	Forced-air cooling			
Dimensions	PCS single unit (W × D × H)	2400×900×1950 mm		
	Substation (W × D × H)	—		
Mass	PCS single unit	2000kg		
	Substation	—		
Environmental conditions	Storage temperature	-20°C to +50°C		
	Operating temperature	-10°C to +40°C		
	Relative humidity	5 to 90%		Non-condensing
	Altitude	1000m or less		
Relevant standard		JIS, JEM, JEC		
Communication system		RS-485		

■ Switchgear and step-up transformer (500kW) specifications

Item	Rated output	500 kW	Remarks
Electric specifications of switchgear	Power supply voltage	6.6 kV	
	Power supply frequency	50/60 Hz	
	Number of power supply phases	Three-phase, three-wire	
	Rated current	200 A	
	Breaking capacity	12.5 kA	
Electric specifications of step-up transformer			Values other than the left value are optional.
	Capacity	500 kVA	
	Number of phases	Three-phase	
	Frequency	50/60 Hz	
	Cooling system	Oil-immersed self-cooling	
	Connection system	△-△	
Others	Contact prevention plate is provided.		

System Configuration Example

One-line diagram (10MW, Outdoor self-standing type, Example of a 1,000 kW PCS)

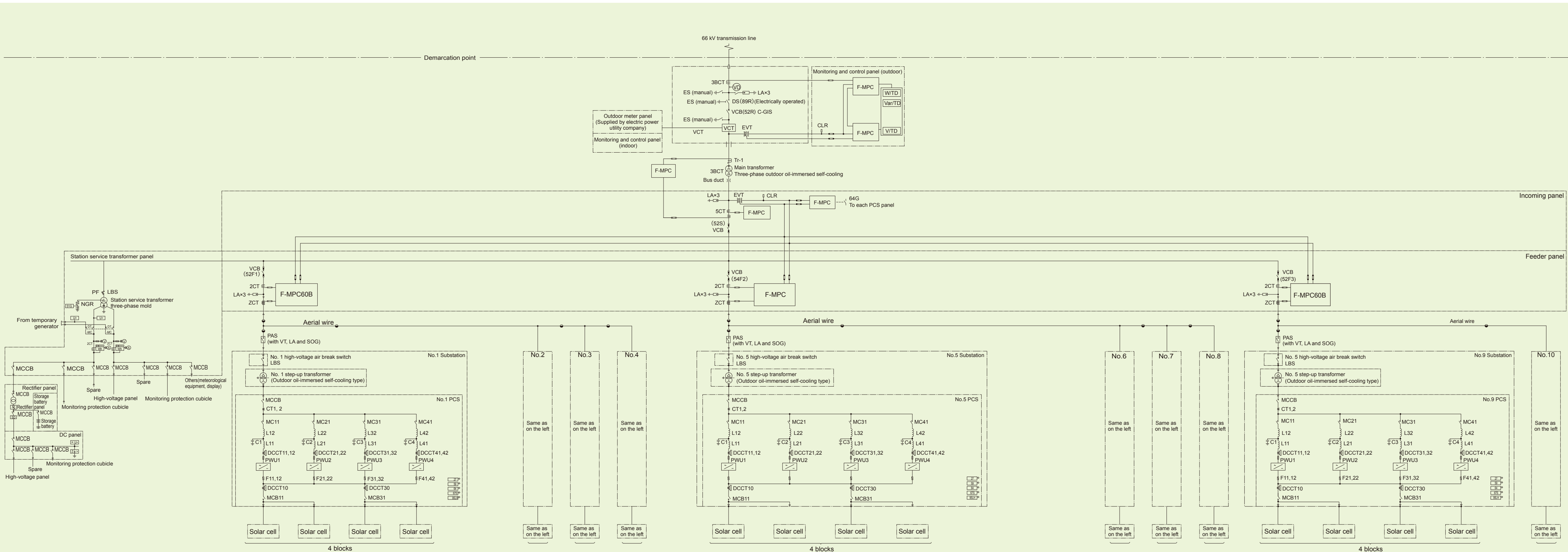

System Configuration Example

One-line diagram (2MW, Outdoor self-standing type, Example of a 1,000 kW PCS)

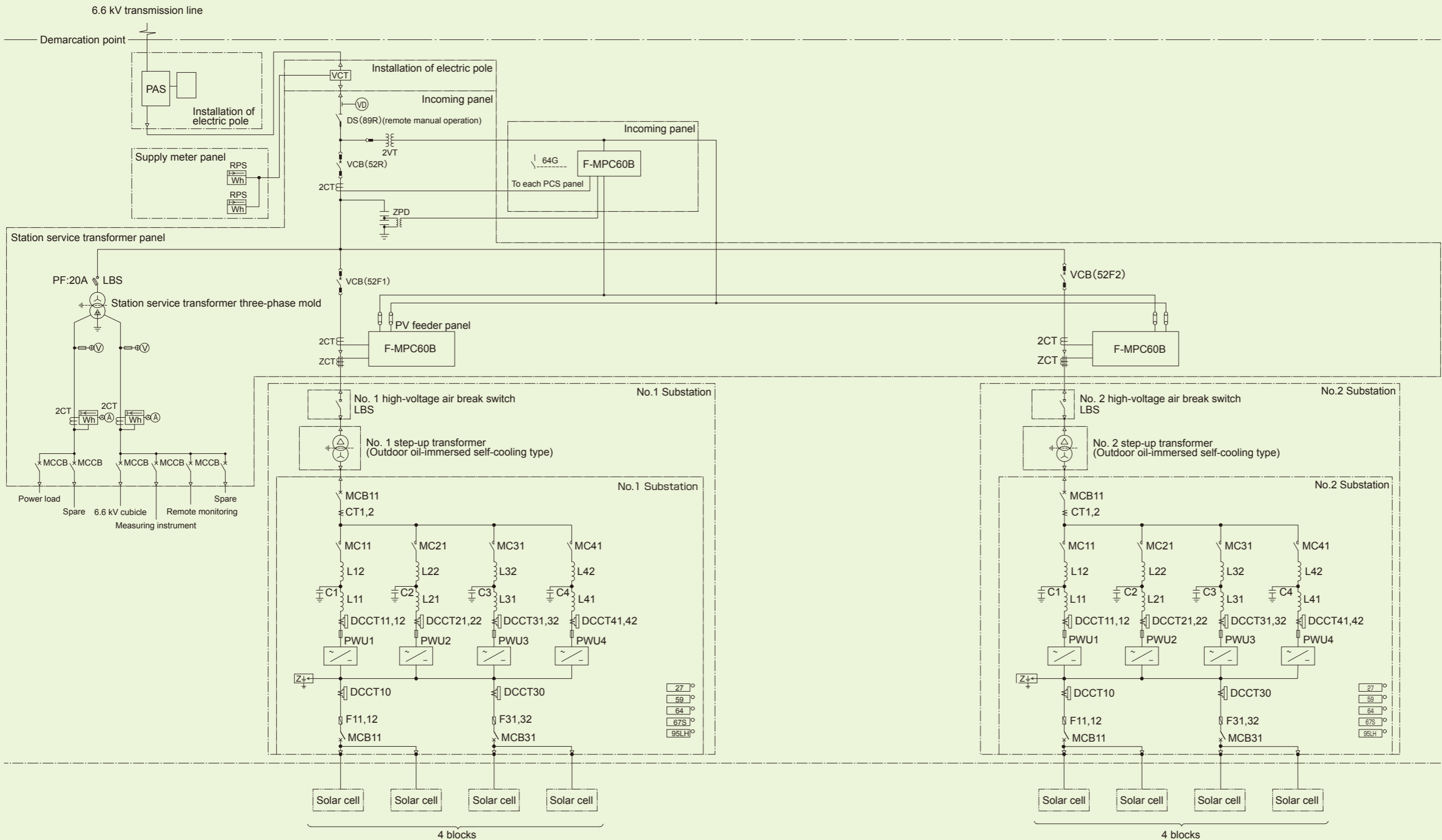

System Configuration Example

One-line diagram (2MW, Indoor self-standing type, Example of a 500 kW PCS)

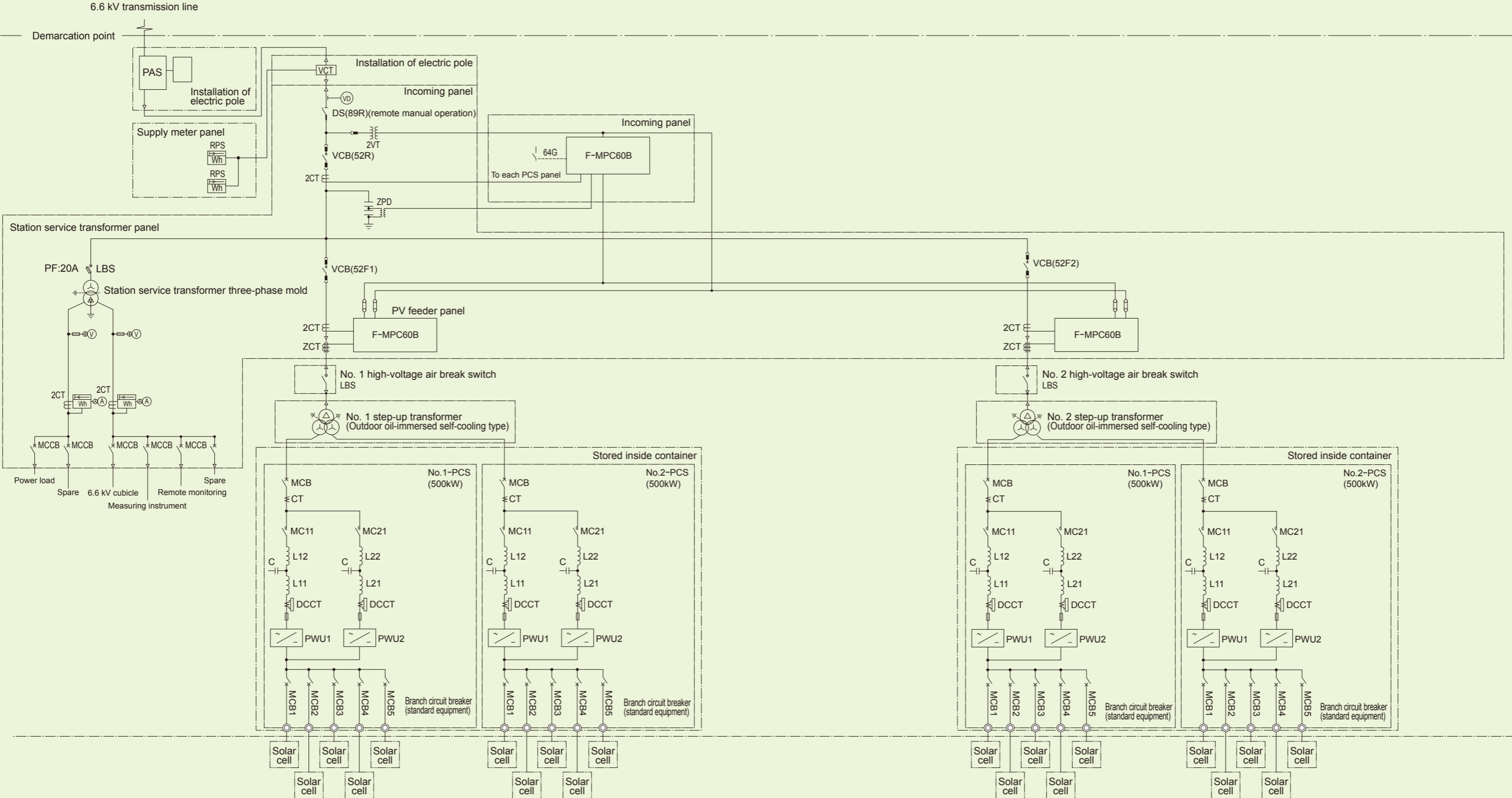

A monitoring unit quickly collects information on proper photovoltaic power generation and the state of each component.

■ Features

The SCADA system has the highest quality and cost performance in the industry. The system has many features such as a web function, multilingual function, **high speed**, **extensibility**, and **reliability**. The system can be applied to a large-scale power generation system with several to more than 400,000 I/O points.

High speed

Optimal performance is achieved every time.

High-speed data collection and display are achieved even in large-scale systems by optimizing every communication and reducing unnecessary communication.

Extensibility

The number of signals can be extended from 75 to 400,000.

Various systems from small- to large-scale configurations can be supported. Also partial system introduction is possible to reduce initial investment.

Reliability

A system with minimal data loss is achieved with a PC-based configuration.

Communication functions and server functions can be provided in completely redundant configurations to build a system that is safe, secure and trouble-free, even in the event of any malfunctions in a PC or in the network.

■ System Configuration Example

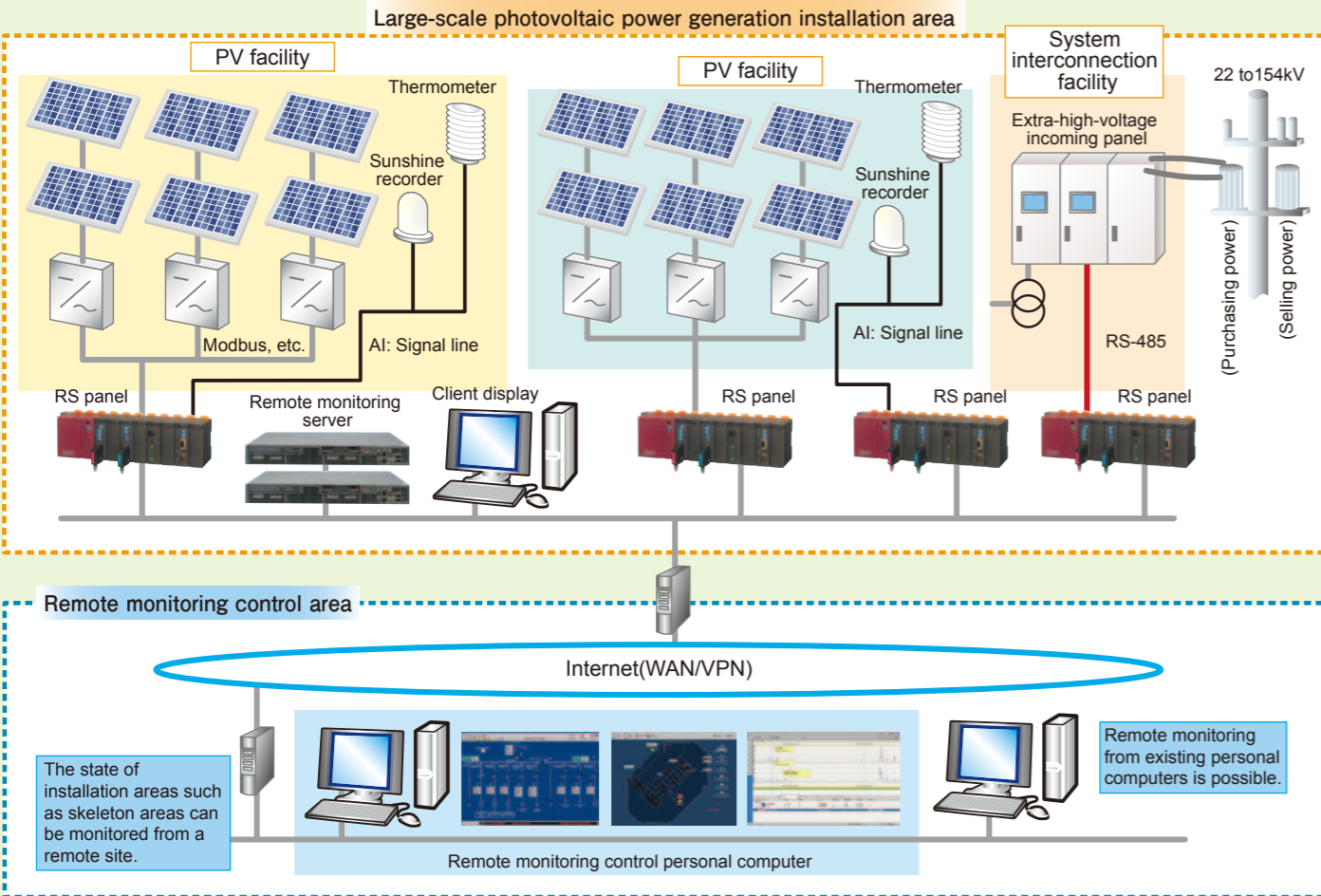

■ Web functions and multilingual functions

- Real-time information on plant status can be accessed from anywhere in the world at any time. (Web connection license is provided)
- Language switching is based on a table system for easy switching to other languages. (For display, Windows fonts are used.)



■ Graphic screen display

Menu screen (top menu, overall area)



Monitoring of each area of photovoltaic panel



Skeleton monitoring screen

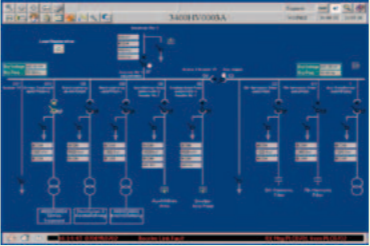

Common screen functions (for example, trends)

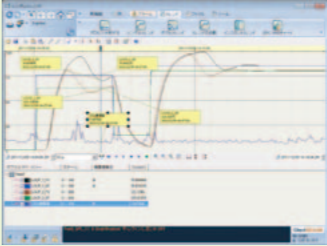

Form output function



■ Citect SCADA using smartphone

A smartphone can be used as a maintenance management tool for facilities. Trends and alarms can be checked through a wireless Windows remote desktop connection.

Radio equipment

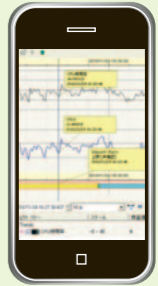
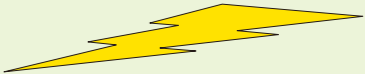

About Microgrids

Fuji Electric also develops renewable energy solutions such as photovoltaic power generation and wind power generation for isolated islands. These microgrid configurations can achieve balanced operation with diesel power generation using a system with an advanced high-performance power PCS and a lithium ion capacitor mounted stabilizer. We participate in many verification tests aiming to reduce CO₂ emissions and power generation costs.

■ Conceptual diagram of microgrid

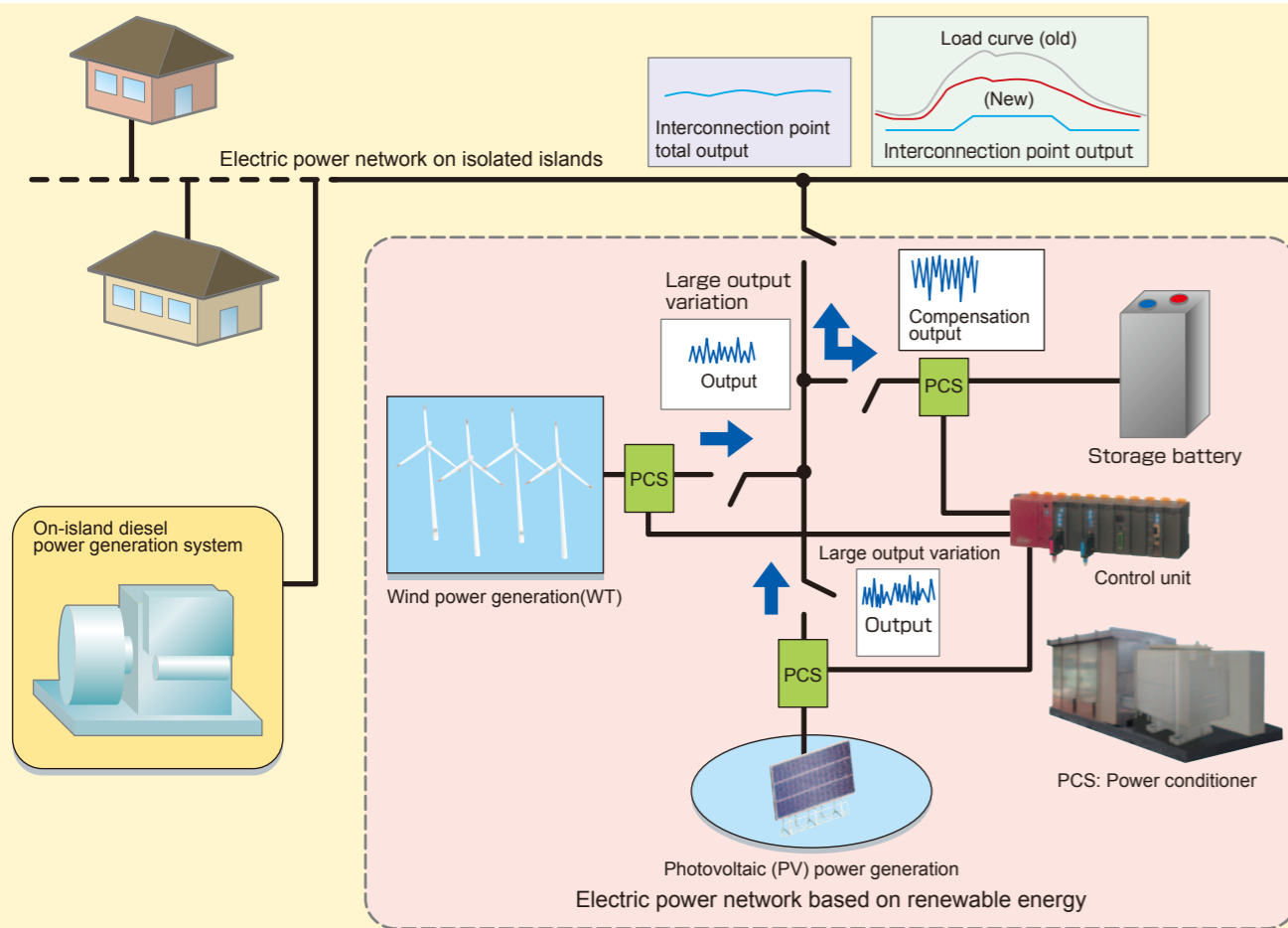

MEMO

Description of verification tests

- 6 islands in Kyushu (verification research in progress)
- 3 islands in Okinawa (verification research in progress)

<Case Study on Tarama Island in Okinawa>

Our lithium ion capacitor equipped stabilizer was introduced to enable high charging and discharging output and high reliability.



Kuroshima Island (Kyushu)



Takarajima Island (Kyushu)



Tarama Island (Okinawa)

Printed on recycled paper

 **Fuji Electric Co., Ltd.**

Gate City Ohsaki, East Tower, 11-2, Osaki 1-chome, Shinagawa-ku, Tokyo 141-0032, Japan
Phone : (03)5435-7111

Internet address : <http://www.fujielectric.co.jp>

Information in this catalog is subject to change without notice.

2012-8(H2012/E2012)PST/CTP100k Printed in Japan