

To All Customers

Rep No.B18076

March 11, 2019

Fuji Electric FA Components &
Systems Co., Ltd.

Notification regarding Change in the External Operating Handle, Retainer, Cover Side Shape, and Screw Bag Specification for Molded Case Circuit Breakers and Earth Leakage Circuit Breakers

We would like to thank you for your continued patronage of Fuji products.
We will be changing some products as described below.
Please review the following information and take appropriate actions.
Please also inform all related sections of your company of these changes.

Product name	Molded Case Circuit Breaker/Earth Leakage Circuit Breaker
Series name	V Type External Operating Handles
Types	BZ6V10C, BZ-V20C, BZ-V50C
Changed parts	(1) Retainer, (2) Cover side, (3) Screw bag label
Details of the change	Details of change (1): The outline dimensions of the retainer will be changed. Details of change (2): The shape of the cover side will be changed. (Applicable to BZ6V10C only) Details of change (3): The label specification for the accessory screw bags will be changed. (Applicable to BZ6V10C only) *For details about the change, refer to the attachments.
Reason for change	Details of change (1): To standardize parts. Details of change (2): To improve the external appearance and assembly workability. Details of change (3): To prevent the inclusion of the wrong accessory screws.
Date of the production change	Scheduled for products to be produced from September 2019
Attachment	Attachment 1: "Details of Retainer Shape Change" Attachment 2: "Details of Cover Side Shape Change" Attachment 3: "Screw Bag Label Specification Change"
Notes concerning the changes	This change will not affect product performance or specifications.

Attachment 1

Details of Retainer Shape Change

Rep No.B18076

March 11, 2019

Fuji Electric FA Components & Systems Co., Ltd.

<Applicable Types>

BZ6V10C, BZ-V20C, BZ-V50C

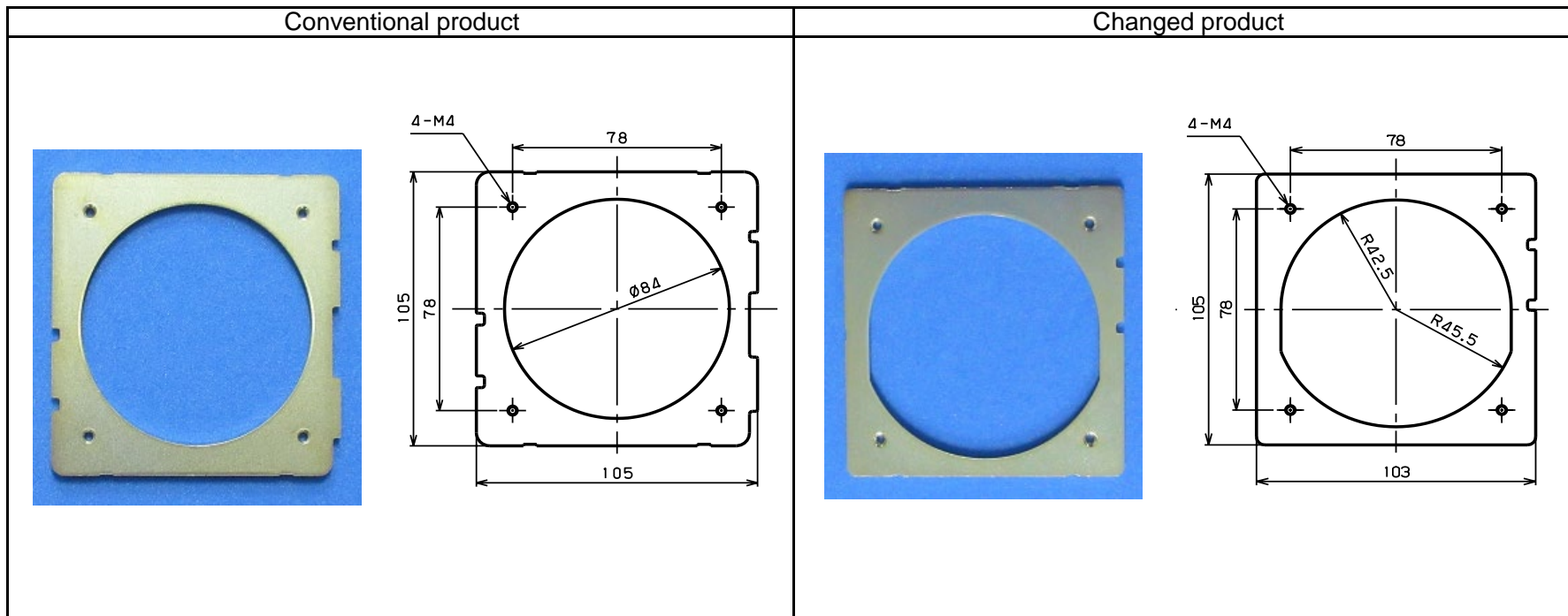

Attachment 2
Details of Cover Side Shape Change

Rep No.B18076
March 11, 2019

Fuji Electric FA Components & Systems Co., Ltd.

<Applicable Types>
BZ6V10C

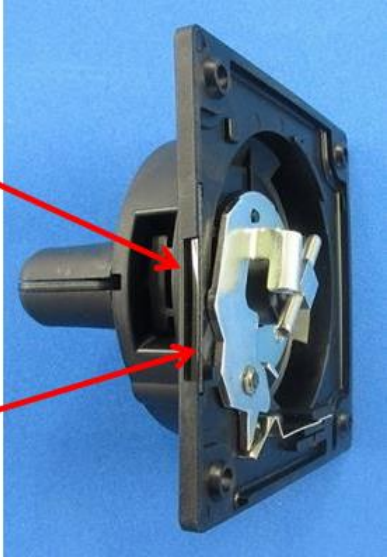
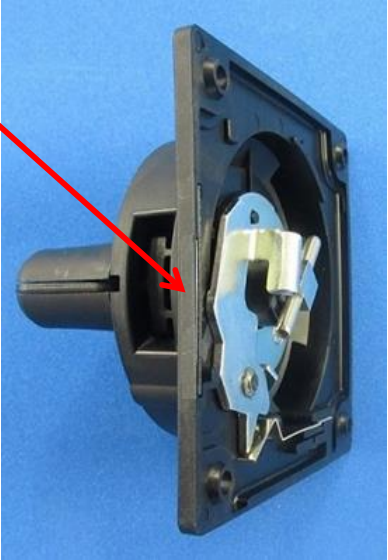
Conventional product	Changed product
<p data-bbox="203 687 439 715">Cover side shape</p> <p data-bbox="203 751 533 778">Cover recess + side wall</p>  <p data-bbox="248 1193 389 1254">Side wall closing part</p>  <p data-bbox="427 863 600 890">Cover recess</p> <p data-bbox="488 1121 607 1149">Side wall</p>	<p data-bbox="1088 679 1323 707">Cover side shape</p> <p data-bbox="1088 743 1458 804">Integral molding of cover to form the outer shell</p> 

Attachment 3

Screw Bag Label Specification Change

Rep No.B18076

March 11, 2019

Fuji Electric FA Components & Systems Co., Ltd.

<Applicable Types>
BZ6V10C

Conventional product	Changed product
 A photograph of a blue screw bag with a white label. The label contains the text "54765485" and "VP".	 A photograph of a blue screw bag with a white label. The label contains the text "BZ6V10C" and "FUJIELECTRIC". Red boxes highlight "BZ6V10C" and "FUJIELECTRIC". Red arrows point from the text "Addition of type" to "BZ6V10C" and "Addition of our control number" to "FUJIELECTRIC".