

Automotive Power MOSFETs

Koji Horiuchi
Yasuhiko Arita
Takeyoshi Nishimura

1. Introduction

As the automobile industry has increasingly used electronic components and systems in recent years for the purpose of making car bodies that are lighter in weight and achieving better fuel efficiency, the use of electronic control units (ECUs) has advanced.

In particular, the transition from power steering systems that use conventional oil pressure control to DC motors that use electronic control (hereafter referred to as electric power steering ECUs) has been particularly rapid, and similarly, headlights are transitioning from conventional halogen bulbs to discharge bulbs that use electronically controlled ballast devices.

Additionally, environmental problems such as global warming have led to the commercialization of products one-after-another such as hybrid vehicles, electric vehicles and fuel-cell vehicles. In accordance with the trends in these automotive fields, there is strong demand for the improved performance of power MOSFETs which are used as the switching devices in ECUs.

Fuji Electric has responded to the trend of increased usage of electronic components and systems in automobiles by developing and commercializing various power MOSFETs.

This paper will introduce the product line, features and future development trends of Fuji Electric's automotive power MOSFETs.

2. Fuji Electric's Product Line of Automotive Power MOSFETs

Table 1 lists Fuji Electric's product line of automotive power MOSFETs and Fig. 1 shows the external appearance of those packages. As MOSFETs for electric power steering ECUs, Fuji provides a 60 V product line for 12 V battery-use and provides a partial lineup of 75 V products capable of supporting the upcoming changeover to 42 V power sources (36 V battery voltage) in the future. Fuji also has a line of 100 to 200 V MOSFETs for use in the DC-DC converter of hybrid vehicles and a line of 500 to 600 V MOSFETs for use in the electronic ballast circuits for discharge

bulbs.

3. Features of Fuji Electric's Automotive Power MOSFETs

3.1 Features of MOSFETs for electronic power steering systems

Electric power steering ECUs mainly use 60 V MOSFETs, but the upcoming changeover to a 42 V power source has led to requests for 75 V products.

These 60 V and 75 V MOSFET products utilize trench structure technology to realize lower ON-resistance and smaller package size. Features of the electric power steering MOSFETs are introduced below.

- (1) Low ON-resistance chip structure and high gate reliability

Figure 2 shows a cross-sectional comparison of the conventional planar chip structure and the trench chip structure.

A characteristic of the trench chip structure is a concave structure fabricated at the gate by means of precision controlled etching. This structure enables the channel resistance component to be decreased, which had been difficult to achieve with the conventional planar chip construction, and also drastically reduces the resistance component due to a JFET effect. Figure 3 shows a comparison of the ON-resistance components of a 60 V conventional planar chip and a trench chip.

Fuji Electric has optimized the trench shape, uniform gate oxidation layer and the polysilicon layer that forms the gate electrode to achieve gate reliability capable of maintaining a high gate voltage ($V_{GS} = 30$ V) simultaneously with low ON-resistance.

- (2) Optimization of the gate threshold voltage

The MOSFETs used in electric power steering ECUs are selected based on their low ON-resistance characteristics, and because the chip design involves a tradeoff between ON-resistance characteristics and gate threshold voltage, MOSFETs having a low gate threshold voltage of approximately 1 to 2 V are commonly used. However, a low gate threshold voltage is susceptible to malfunction caused by noise and the

Table 1 Fuji Electric's product line of automotive power MOSFETs

Targeted application such as ECUs	Model number	Main product specification				Remark
		V_{DSS} (V)	I_D (A)	$R_{DS(on)}$ (Ω)	Package	
ECUs for electric power steering	2SK3270-01	60	80	6.5 m	TO-220AB	
	2SK3271-01	60	100	6.5 m	TO-3P	
	2SK3272-01L, S	60	80	6.5 m	D ² -Pack	
	2SK3273-01MR	60	70	6.5 m	TO-220 full-mold	
	F1519	60	80	6.0 m	D ² -Pack	Under development
	2SK3730-01MR	75	70	8.5 m	TO-220 full-mold	
	2SK3804-01S	75	70	8.5 m	D ² -Pack	Under development
	F1515	75	80	8.5 m	TO-247	Under development
	2SK3644-01	100	30	44 m	TO-220AB	
	2SK3645-01MR	100	30	44 m	TO-220 full-mold	
Hybrid electric vehicles, Electric vehicles, DC-DC converters, Electronic ballast for discharge bulbs (DC-DC converter/ inverter units)	2SK3646-01L, S	100	30	44 m	D ² -Pack	
	2SK3590-01	150	40	41 m	TO-220AB	
	2SK3591-01MR	150	40	41 m	TO-220 full-mold	
	2SK3592-01L, S	150	40	41 m	D ² -Pack	
	2SK3594-01	200	30	66 m	TO-220AB	
	2SK3595-01MR	200	30	66 m	TO-220 full-mold	
	2SK3596-01L, S	200	30	66 m	D ² -Pack	
	2SK3504-01	500	14	0.46	TO-220AB	
	2SK3505-01MR	500	14	0.46	TO-220 full-mold	
	2SK3450-01	600	12	0.65	TO-220AB	
	2SK3451-01MR	600	12	0.65	TO-220 full-mold	

Fig.1 External appearance of packages

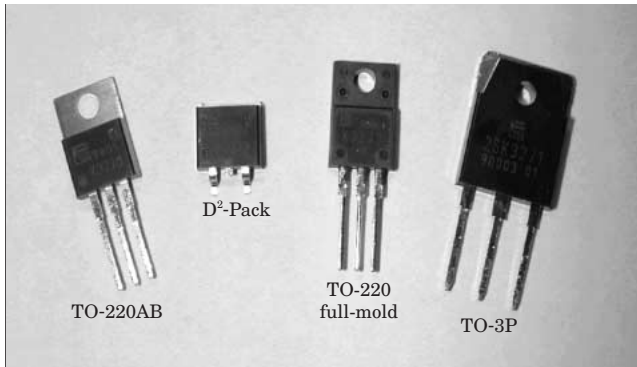

Fig.2 Planar chip structure and trench chip structure

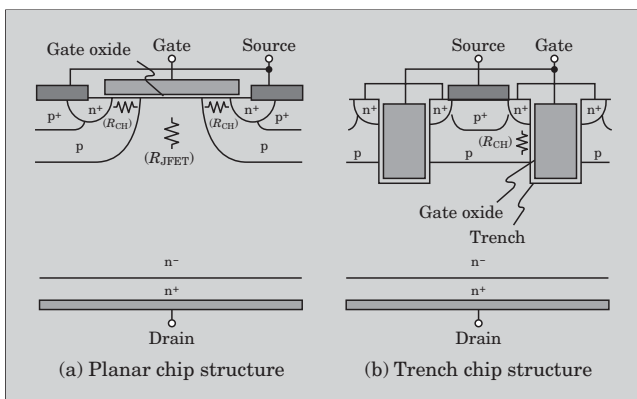
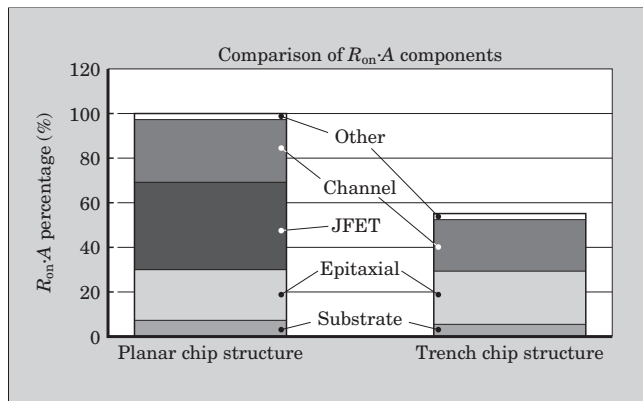

Fig.3 Comparison of the ON-resistance components of a 60 V conventional planar chip and a trench chip (60 V) [per unit area: $R_{on} \cdot A$]



like.

Fuji Electric's MOSFETs for electric power steering applications have an optimized gate threshold voltage of 3 V (typical value) and therefore the target circuitry can easily be configured to include anti-noise measures to prevent malfunction due to noise generated in the interconnects to gate peripheral circuitry.

(3) Highly reliable package compatible with large currents

An ECU system for electric power steering use as shown in Fig. 4 must have a highly reliable package capable of withstanding instantaneous large currents

due to: 1) a load short-circuit of the DC motor, 2) a short-circuit to ground in the wiring harness that connects the DC motor and ECU, 3) an arm short-circuit between upper and lower devices that comprise of an H bridge or a 3-phase bridge, and so forth.

Figure 5 shows the internal structure of Fuji Electric's trench power MOSFET. When an electric power steering ECU operates at maximum torque (motor current of approximately 30 to 65 A), the large current flow causes power loss to occur in the chip and is dissipated as thermal energy and an even larger emission of thermal energy is dissipated in the lead wiring that connects to external pins. In consideration of the above problem, Fuji Electric has optimized the chip design by, (1) increasing the diameter of the internal connecting wire, and (2) by using multiple internal connecting wires.

Provided with the above features, Fuji Electric's electric power MOSFETs are being used in a wide range of applications in addition to those listed above.

(4) 75 V MOSFET product line

Although a battery voltage of 12 V is used at

Fig.4 Equivalent circuit of electric power steering ECU system (3-phase motor control)

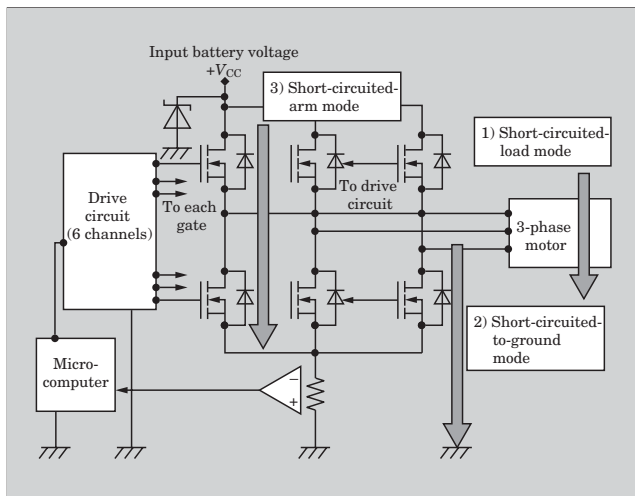
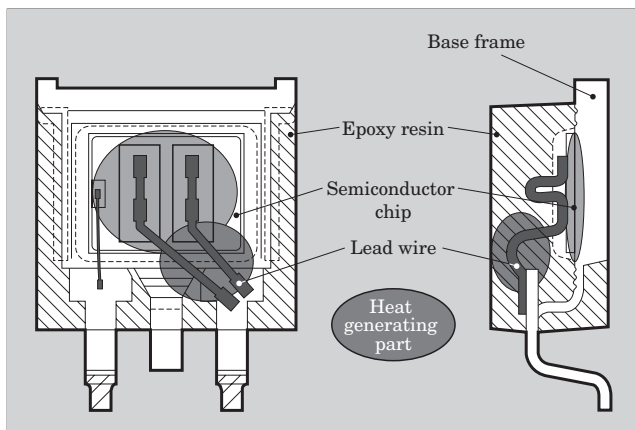

Fig.5 Internal structure of Fuji Electric's trench power MOSFET (surface mount type)



present, in order to support the future transition to a 42 V power source (36 V battery), Fuji Electric also provides a 75 V product line. Table 2 shows the main ratings and Table 3 shows the electrical characteristics of the 75 V product line. This product line is characterized by a high voltage of 75 V and by low ON-resistance (8.5 mΩ maximum).

3.2 Features of Fuji Electric's MOSFETs for use in DC-DC converters and electronic ballast circuits

Figure 6 shows a ballast device system for controlling a discharge bulb. 100 to 200 V MOSFETs are used in DC-DC converters to boost the battery voltage and 500 to 600 V MOSFETs are used in inverter units to generate a high voltage for a discharge bulb. A DC-DC converter requires a MOSFET capable of high-frequency switching operation in order to realize a compact and lightweight step-up transformer, and an inverter requires a high-voltage and high-speed MOSFET capable of withstanding the high voltage during the bulb unloaded output state of approximately 380 V and the high dv/dt at the beginning of bulb discharge. In response to these requests, Fuji Electric provides the SuperFAP-G product line which has high speed and low ON-resistance. This SuperFAP-G product line incorporates the new technology of a quasi-planar junction (QPJ) shown in Fig. 7 and achieves a high level of performance that is only 10 % less than the theoretical performance limit of silicon (Si).

Features of this product line are listed below (in comparison to the conventional 600 V product line).

- (1) 75 % decrease in turn-off loss
- (2) 60 % decrease in gate charge
- (3) High avalanche withstand capability
- (4) Package product line that includes various surface mount packages

By providing the above SuperFAP-G product line, Fuji Electric is able to supply MOSFETs that are ideally suited for DC-DC converter and electronic ballast applications.

Table 2 Main ratings of Fuji Electric's 75 V automotive power MOSFET ($T_C = 25^\circ\text{C}$)

Item	Symbol	Rating	Unit	Remark
Drain-source voltage	V_{DS}	75	V	
	V_{DSX}	40	V	$V_{GS} = -20\text{ V}$
Continuous drain current	I_D	± 70	A	
Pulsed drain current	I_{DP}	± 280	A	
Gate-source voltage	V_{GS}	+30/-20	V	
Maximum avalanche energy	E_{AV}	443.8	mJ	$L = 84.5\ \mu\text{H}$, $V_{CC} = 48\text{ V}$
Maximum power dissipation	P_D	162	W	
Operating temperature range	T_{ch}	175	$^\circ\text{C}$	
Storage temperature range	T_{stg}	-55 to +175	$^\circ\text{C}$	

Table 3 Electrical characteristics of Fuji Electric's 75 V automotive power MOSFET ($T_C = 25^\circ\text{C}$ unless specified otherwise)

(a) Static characteristics

Item	Symbol	Measurement condition	Standard value			Unit
			Min.	Typ.	Max.	
Drain-source breakdown voltage	BV_{DSS}	$I_D = 1 \text{ mA}$ $V_{GS} = 0 \text{ V}$	75	-	-	V
	BV_{DSX}	$I_D = 1 \text{ mA}$ $V_{GS} = -20 \text{ V}$	40	-	-	V
Gate threshold voltage	$V_{GS(th)}$	$I_D = 10 \text{ mA}$ $V_{DS} = V_{GS}$	2.5	3.0	3.5	V
Zero gate voltage drain current	I_{DSS}	$V_{DS} = 75 \text{ V}$ $V_{GS} = 0 \text{ V}$	-	1.0	100	μA
		$T_{ch} = 25^\circ\text{C}$ $T_{ch} = 125^\circ\text{C}$	-	10	500	μA
Gate-source leakage current	I_{GSS}	$V_{GS} = +30 / -20$ $V_{DS} = 0 \text{ V}$	-	10	100	nA
Drain-source ON-state resistance	$R_{DS(on)}$	$I_D = 35 \text{ A}$ $V_{GS} = 10 \text{ V}$	-	6.4	8.5	m Ω

(b) Dynamic characteristics

Item	Symbol	Measurement condition	Standard value			Unit
			Min.	Typ.	Max.	
Forward transconductance	g_{fs}	$I_D = 35 \text{ A}$ $V_{DS} = 10 \text{ V}$	25	50	-	S
Input capacitance	C_{iss}	$V_{DS} = 25 \text{ V}$ $V_{GS} = 0 \text{ V}$ $f = 1 \text{ MHz}$	-	7,500	-	pF
Output capacitance	C_{oss}		-	1,050	-	
Reverse transfer capacitance	C_{rss}		-	500	-	
Turn-on time	$t_{d(on)}$ t_r	$V_{cc} = 38 \text{ V}$ $V_{GS} = 10 \text{ V}$ $I_D = 70 \text{ A}$ $R_G = 10 \Omega$	-	50	-	ns
			-	90	-	
Turn-off time	$t_{d(off)}$ t_f	$V_{cc} = 38 \text{ V}$ $I_D = 70 \text{ A}$ $V_{GS} = 10 \text{ V}$	-	150	-	ns
			-	90	-	
Total gate charge	Q_g	$V_{cc} = 38 \text{ V}$	-	150	-	nC
Gate-source charge	Q_{gs}	$I_D = 70 \text{ A}$	-	30	-	
Gate-drain charge	Q_{gd}	$V_{GS} = 10 \text{ V}$	-	45	-	

(c) Parasitic diode characteristics

Item	Symbol	Measurement condition	Standard value			Unit
			Min.	Typ.	Max.	
Avalanche withstand capability	I_{AV}	$L = 84.5 \mu\text{H}$ $T_{ch} = 25^\circ\text{C}$	70	-	-	A
Diode forward ON-voltage	V_{SD}	$I_F = 75 \text{ A}$ $V_{GS} = 0 \text{ V}$ $T_{ch} = 25^\circ\text{C}$	-	1.3	1.65	V
Reverse recovery time	t_{rr}	$I_F = 35 \text{ A}$ $V_{GS} = 0 \text{ V}$	-	95	-	ns
Reverse recovery charge	Q_{rr}	$-di/dt = 100 \text{ A}/\mu\text{s}$ $T_{ch} = 25^\circ\text{C}$	-	0.30	-	μC

(d) Thermal characteristics

Item	Symbol	Measurement condition	Standard value			Unit
			Min.	Typ.	Max.	
Thermal resistance	$R_{th(ch-e)}$		-	-	0.926	$^\circ\text{C}/\text{W}$
	$R_{th(ch-a)}$		-	-	75.0	$^\circ\text{C}/\text{W}$

Fig.6 Ballast device system

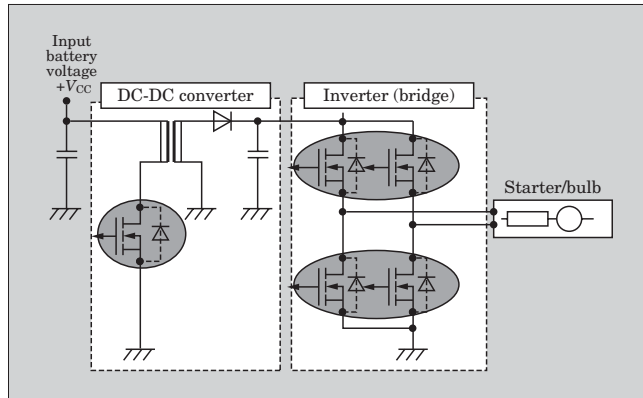
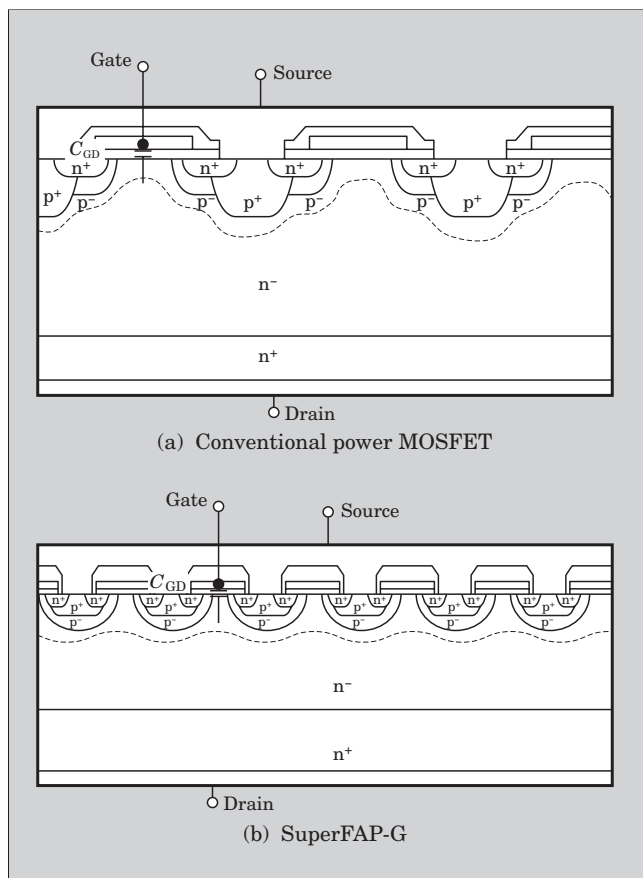

Fig.7 Chip structure of SuperFAP-G product line



4. Future Development Trends

In addition to Fuji Electric's existing 60 V product line that has a track record of successful use in electric power steering application and the new 75 V product line, we are also endeavoring to develop high performance products that utilize next generation technology.

The design goals for these high performance products, for which development and commercialization being advanced, are listed below.

- (1) Product voltage V_{DS} : 60 V, 75 V

Fig.8 Comparison of switching characteristics (gate charge) of a conventional 60 V MOSFET and a new high-performance 60 V MOSFET

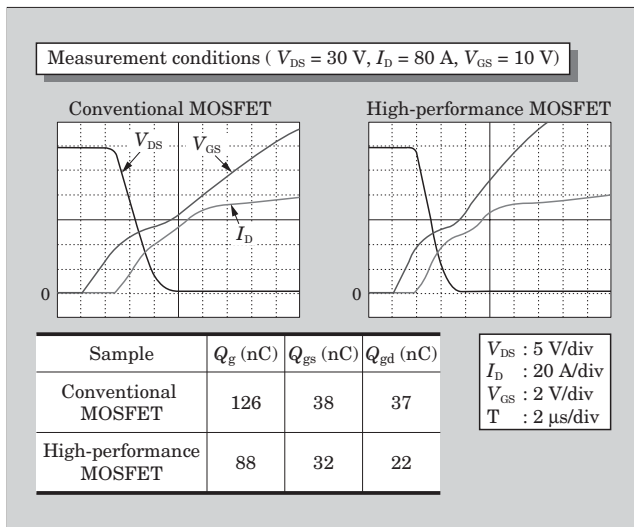

- (2) Rated current I_D : 70 to 80 A
- (3) Gate threshold voltage: 2.5 to 3.5 V
- (4) ON-resistance, $R_{on} \cdot A$: 20 % less than conventional products
- (5) Input capacitance C_{iss} : 30 % less than conventional products
- (6) Package lineup: Stand-alone packages (as typified by the TO-220) and surface mount packages

Figure 8 shows a comparison of the switching waveforms (gate charge) for a 60 V engineering sample of a product presently under development and a conventional MOSFET and Fig. 9 compares the results of a simulation of loss generation for these two devices assuming use as in an electric power steering application and a carrier frequency of 20 kHz.

According to these comparative results, an approximate 40 % improvement in gate charge quantity (Q_g), effective in reducing loss during gate driving, and an approximate 18 % in loss generation at 20 kHz are achieved.

Based on the above results, by endeavoring to

Fig.9 Comparison of loss generated by a conventional 60 V MOSFET and a new high-performance 60 V MOSFET (simulated results)

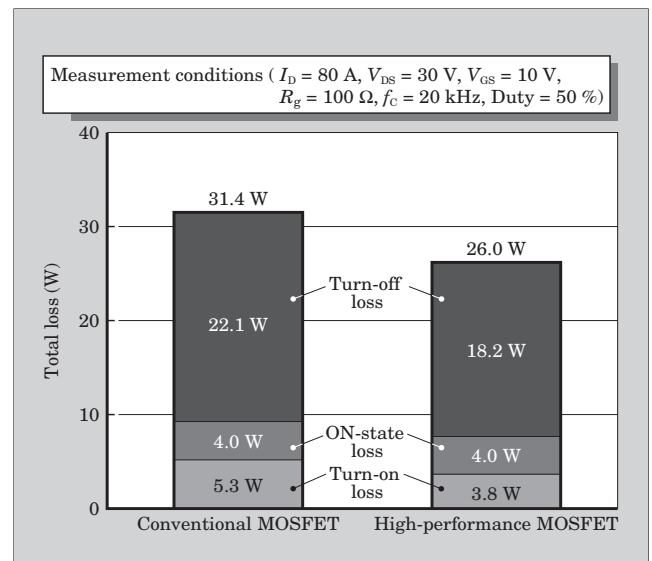

improve the various main specifications and to enhance performance, higher performance can be achieved not only as a MOSFET for electric power steering applications, but by developing other product lines, higher performance can be achieved for additional applications as well.

5. Conclusion

Fuji Electric has developed and commercialized various automotive power MOSFETs including those described herein. We are committed to continue developing and providing distinctive products to satisfy the needs for electronic parts and systems and to expand the field of automotive electronics.

Reference

- (1) Yamazaki, T. et al. Low Q_{gd} Trench Power MOSFETs with Robust Gate for Automotive Applications. PCIM2003.