

## MICREX-SX Series SPH

# Market Release of Analog Module for Instrumentation

We would like to thank you for your continued patronage of Fuji Programmable Controllers.

Please be informed that Fuji Electric FA has released the MICREX-SX SPH Analog Module for instrumentation.

### 1. Models Released

Product name	Model (Product code)	General specifications
Distributor Module	NP1AXH4DG-MR	2-wire transmitter input with a resolution of 16 bits Current input x 4 channels isolated from each other
Flow Meter F/AD Conversion Module	NP1F-PI4	Conversion of pulse output values of flow meters into instantaneous/integrated values Input x 4 channels isolated from each other

### 2. Start of Sales

May 2008

### 3. Distributor Module Outline

#### 3-1 Features

The distributor module converts 4- to 20-mA input signals from two-wire transmitters, such as flow meters of differential pressure type, water gauges, or temperature transmitters, into digital data.

- (1) Insulation between channels  
Because each channel is isolated with a high dielectric strength (1 kVAC), no external transducer is required.
- (2) Built-in power supply  
Each channel incorporates a 24-VDC power supply for two-wire transmitters, so no external power supply is required. A current limiter is also incorporated to limit short-circuit current.
- (3) High precision and high resolution  
High precision and high resolution, with an AI of  $\pm 0.1\%$  and 16 bits, enable precise measurement.
- (4) Easy range setup  
Range settings (common to all channels) can be made with the rotary switch on the back. A square root extraction function is selectable. Therefore, values can be input directly, much like industrial values, in order to obtain output with square root extraction from flow meters of differential pressure type.
- (5) Connections with various FB packages  
Digital value ranges can be converted into percent values by scaling and directly connected as PVs to expansion FB units for PID operation FB packages. This allows alarm output, PID operation, polygonal line approximation operation, and ratio operation to be easily added.

### 3-2 Distributor Module Appearance

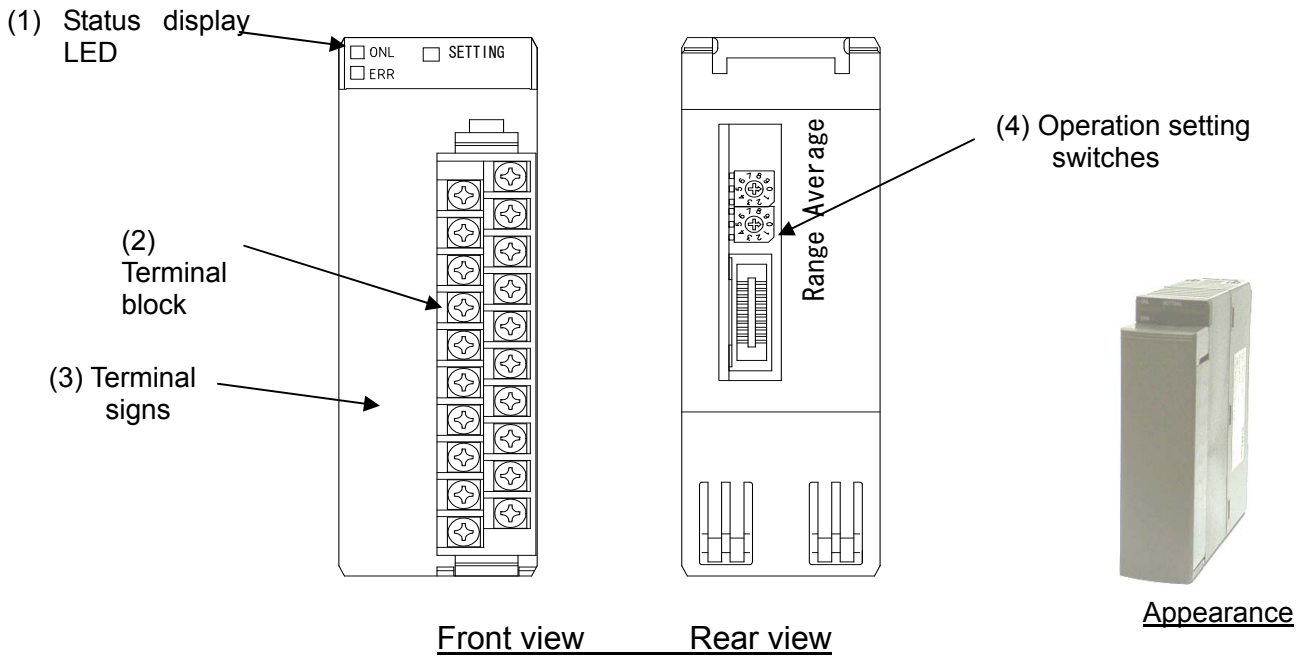

#### (1) Status display LED

State	ONL (Green)	ERR (Red)	Setting (Green)
During initialization	Blinks	Off	Off
During normal operation	Lit	Off	Off
Offset/gain adjustment	Lit	Off	Blinks
In case of fatal fault	Off	Lit	Off

#### (2) Terminal block

An M3 detachable terminal block for I/O wiring. The mounted module can be replaced without having to remove wires.

#### (3) Terminal label

Terminal signs and numbers are printed.

#### (4) Operation setting switches

Used to set the operation range of the distributor module and the average number of shifts. Range switches are set between 0 and 7 for all the channels. In order to make range settings on a per channel basis, set the operation range to software with the range set to 8 so that the individual range settings can be made with an application program. Offset/gain adjustments are also possible when the operation is set to a range other than software.

<Operation Setting Switches>

Range switch No.	Operation range	Square root extraction	Conversion value range
0 (factory set)	4 to 20mA	No	0 to 32000
1			0 to 16000
2			0 to 10000
3		Yes	0 to 32000
4			0 to 10000
5	0 to 20mA	No	0 to 32000
6			0 to 16000
7			0 to 10000
8	Software setting range	---	---
9	Not used (operated with switch No. 0)		

Average switch No.	Average number of shifts
0 (factory set)	Once (moving average)
1	8 times (moving average)
2	16 times (moving average)
3	32 times (moving average)
4	Not used (operated with switch No. 0)
5	
6	
7	
8	
9	

### 3-3 Distributor Module Specifications

Model	NP1AXH4DG-MR
Number of inputs	4
Analog input range	4 to 20mA or 0 to 20mA
Input impedance	250Ω
Maximum permissible input	30mA
Input filter	Approx. 200μs or less (Hardware: Primary delay time constant)
Resolution	16 bits
Digital value (INT type)	0 to 32,000
Measurement accuracy	±0.1% of FSR (Ta = 25°C)
Temperature coefficient	±0.007%/°C
Noise maximum deviation	±0.3% of FSR
Conversion cycle	30ms/4 channels
Warm-up time (See note 2.)	40 minutes min.
Transmission power supply (See note 1.)	1) Output voltage: 24VDC±15% 2) Current capacity: 23mA max. 3) Short-circuit restriction current: Approx. 25mA max. 4) Ripple noise: Approx. 250mVp-p max. 5) Load sudden change: 4V <sub>0-P</sub> max. (under a load sudden change condition of 0 to 23mA)
Response time (See note 3.)	Conversion cycle + Tact cycle (ms)
Number of occupied words	8W input + 4W output
Insulation method	Between I/O terminals and FG: Photo-coupler insulation and transformer insulation Between analog input terminals and channels: Transformer insulation
Dielectric strength	1000VAC, one minute, between I/O terminals and FG (Shorted current: 10mA) 1000VAC, one minute, between analog input terminals and channels (Shorted current: 10mA)
Insulation resistance	10MΩ min. (500VDC tester) between I/O terminals and FG 10MΩ min. (500VDC tester) between analog input terminals and channels
Internal current consumption (See note 4.)	390mA max. (with transmission power supply used) 170mA max. (with no transmission power supply used)
Processing of non-used output	Open in principle
Transmission line	Shielded twist pair cable: 500m max.
Mass	Approx. 290g
External connections	Removable screw terminal block (M3 x 20 poles)
Dimensions (W x H x D) in mm	35 x 105 x 111 (Protrusion: 26mm)

Note: 1. The ambient temperature at the time of short-circuiting is 40°C max.

40°C to 55°C: Less than 10 minutes.

2. No warm-up time is required at a measurement accuracy of 0.22% (Ta = 25°C).
3. In the case of step response, a response time of 56.6ms (Response time of 30ms x No. of average shifts + Input filter x 8 + Tact cycle) will apply. (No average movement at a tact cycle of 5ms.)
4. The internal current consumption varies with the number of channels of transmission power supply. The current consumption can be reduced if the number of channels used for transmission power supply is small.

### 3-4 External Wiring Diagram of Distributor Module

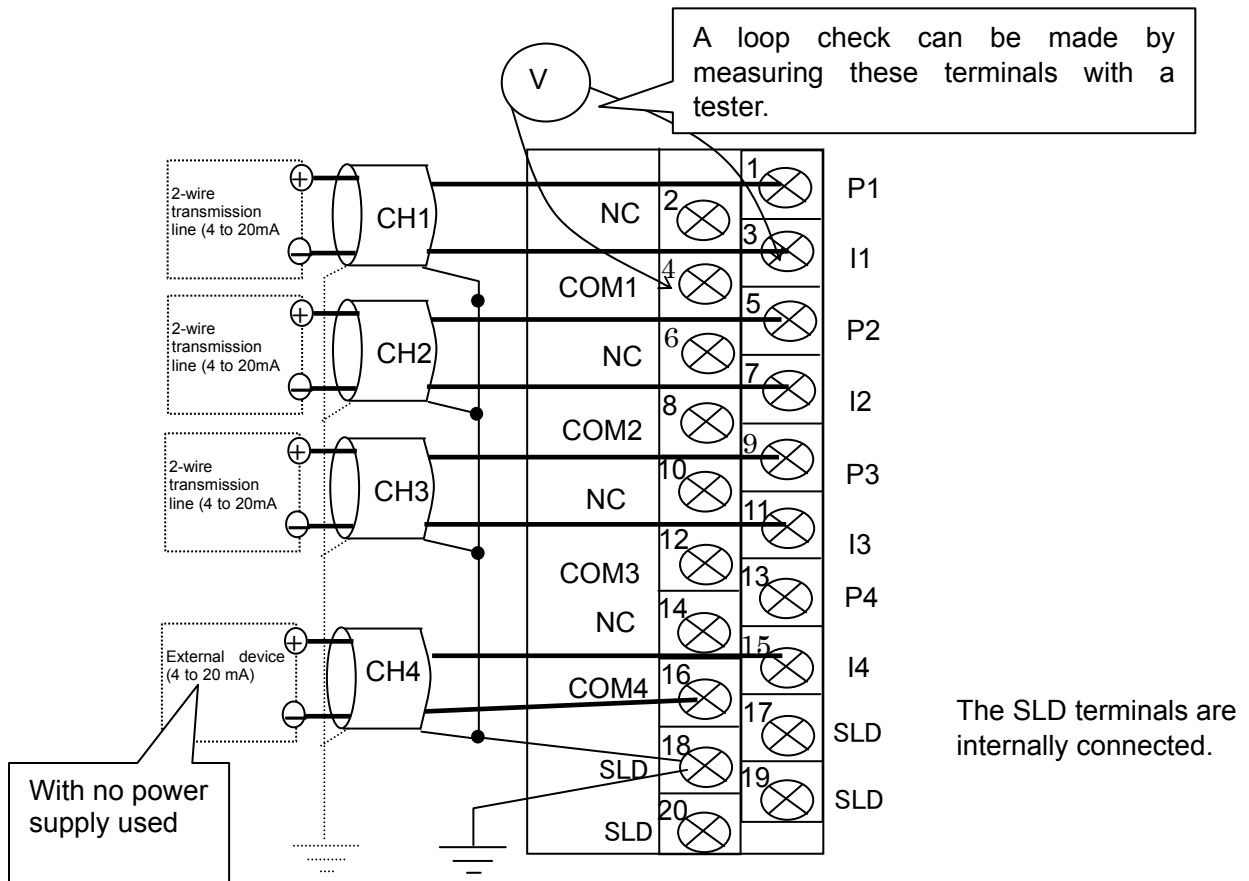

## 4. Outline of F/AD Conversion Module for Flow Meter

### 4-1 Features

The F/AD conversion module converts pulse input signals from flow meters into instantaneous values or integrated values.

(1) Insulation between channels

Because each channel is isolated with a high dielectric strength (1 kVAC), no external transducer is required.

(2) Multi-functional display

Instantaneous and integrated flow rates are displayed simultaneously.

(3) A wide variety of external connections

The module supports the following types of inputs and connects to a variety of flow meters, such as volumetric flow meters, without requiring an external power supply.

- (1) 2-wire non-voltage semiconductor input
- (2) 2-wire contact input
- (3) 2-wire voltage input
- (4) 3-wire non-voltage semiconductor input
- (5) 3-wire voltage input
- (6) 2-wire current input

(4) Built-in sensor power supply

A sensor power supply voltage of 13.5 or 24 V is selectable for each channel. A current limiter is also incorporated to limit short-circuit current.

(5) Built-in chattering removal filter and input impedance selectable functions

Input impedance and a chattering removal filter are selectable for each channel.

(6) Functions at the highest level of this class

The module incorporates versatile functions, such as pulse weight, integrated value step-down, moving averaging, and pulse monitoring time functions, which can be set for each channel independently.

(7) Connection with Various FB Packages

Digital value ranges can be converted into percent values by scaling and directly connected as PVs to expansion FB units for PID operation FB packages. This allows alarm output, PID operation, polygonal line approximation operation, and ratio operation to be easily added. The number of digits of an integrated value can also be increased to a double word by combining FB packages.

## 4-2 F/AD Conversion Module for Flow Meters

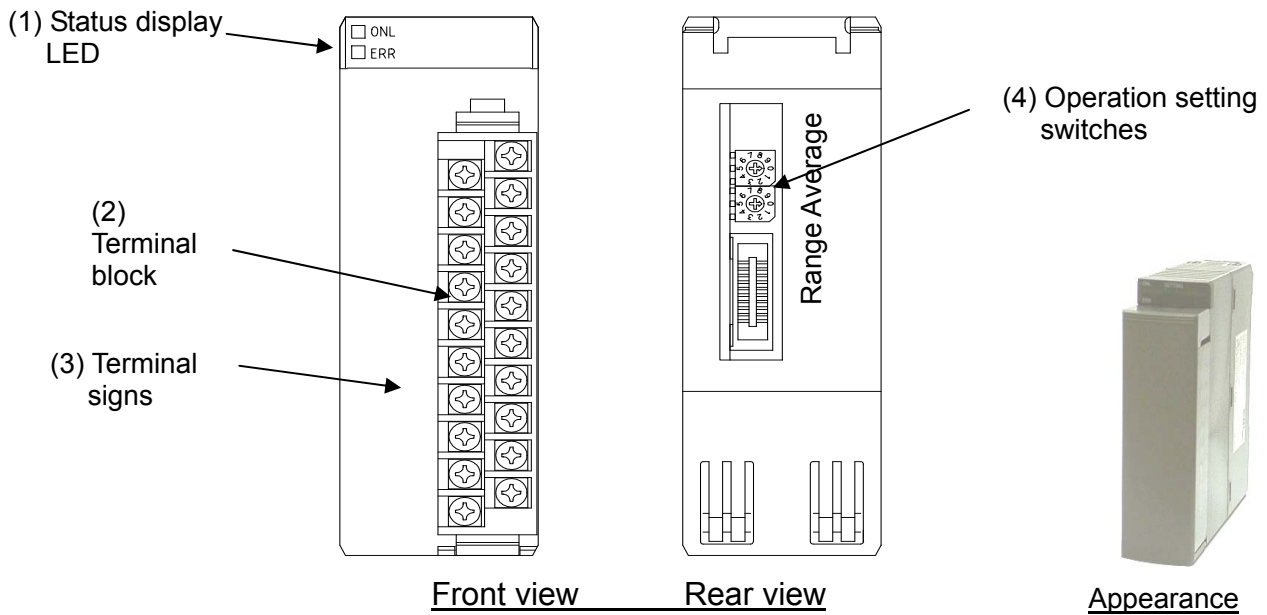

### (1) Status display LED

State	ONL (Green)	ERR (Red)
During initialization	Blinks	Off
During normal operation	Lit	Off
In case of fatal fault	Off	Lit

### (2) Terminal block

An M3 detachable terminal block for I/O wiring. The mounted module can be replaced without having to remove wires.

### (3) Terminal label

Terminal signs and numbers are printed.

### (4) Operation setting switches

Used to set the operation range of the F/AD module.

Range switches are set for all the channels. In order to make range settings on a per channel basis, set the operation range to software so that the individual range settings can be made with an application program.

Parameter resetting is also possible when the operation is set to a range other than software.

<Operation Setting Switches>

Range switch No.	Input frequency range	Instantaneous value unit	Integrated value range
0 (factory set)	0 to 200Hz (0 to 230Hz)	0 to 23000	0 to 9999
1	0 to 200Hz (0 to 230Hz)	0 to 11500	
2	0 to 10Hz (0 to 11.5Hz)	0 to 11500	
3	0 to 100Hz (0 to 115Hz)	0 to 11500	
4	0 to 400Hz (0 to 460Hz)	0 to 11500	
5	0 to 1kHz (0 to 1.5kHz)	0 to 11500	
6	0 to 10kHz (0 to 11.5kHz)	0 to 11500	
7	Software setting range	0 to 11500	
8	Software setting range (integration only)	---	0 to 65535
9	Not used (operated with switch No. 0)	0 to 23000	0 to 9999

Average switch No.	Number of moving times
0 (factory set)	Once
1	4 times
2	6 times
3	8 times
4	10 times
5	12 times
6	14 times
7	16 times
8	Not used (operated with switch No. 0)
9	

The following parameter settings apply when the range is fixed.

Parameter	Set value
Pulse weight	None (1)
Integrated value step down	None (x1)
Pulse monitoring time	65.536 seconds

#### 4-3 Specifications of F/AD Conversion Module for Flow Meters

Model	NP1F-PI4	
Number of inputs	4	
Connectable signal	Non-voltage contact pulse, 2-wire open collector pulse, 3-wire open collector pulse, 2-wire voltage pulse, 3-wire voltage pulse, and 2-wire current pulse	
Input frequency	0 to 10kHz	
Input waveform	Approximation rectangle wave	
Pull-up resistance	22k $\Omega$	
Maximum permissible input	-1 to 30V, 0 to 30mA	
Minimum pulse width	50 $\mu$ s min. (50ms min. with filter set)	
Input signal level	Contact input (relay and transistor)	Disregard level: ON: 200 $\Omega$ max.; OFF: 100k $\Omega$ Contact capacity: 15VDC, 15mA min. at sensor power supply voltage of 13.5V 30VDC, 30mA sensor power supply of 24V
	Voltage/Current pulse	Detection level: 3Vp-p (Voltage-converted value in the case of current input)
Input impedance	Selectable from disabled (10k $\Omega$ min.), 200 $\Omega$ , 500 $\Omega$ , and 1k $\Omega$	
Input pulse detection method	AC coupling and rising edge detection	
Integrated value renewal cycle	5ms/4 points (See note 1.)	
Response time	Integrated value renewal cycle + Tact cycle Instantaneous value renewal cycle + Tact cycle	
Sensor power supply (See note 2.)	1) Output voltage: 13.5VDC $\pm$ 15%/24V $\pm$ 15% (selectable) 2) Current capacity: 13.5 VDC: 35mA max.; 24VDC: 24mA max. 3) Short-circuit restriction current: 13.5VDC: Approx. 40mA; 24VDC: Approx. 28mA 4) Ripple noise: Approx. 250mVp-p max. 5) Load sudden change: 3 V <sub>0-P</sub> (under a load sudden change condition of 0mA to 40mA)	
Filter function	Chattering removal filter selectable (Time constant: Approx. 4ms)	
Occupied words	8 input words and 4 output words	
Insulation method	Between pulse input terminals and FG: Photo-coupler insulation and transformer insulation Between pulse input terminals and channels: Transformer insulation	
Dielectric strength	1000VAC, one minute, between I/O terminals and FG (Shorted current: 10mA) 1000VAC, one minute between analog input terminals and channels (Shorted current: 10mA)	
Insulation resistance	10M $\Omega$ or more (500VDC tester) between pulse input terminals and FG 10M $\Omega$ or more (500VDC tester) between pulse input terminals and channels	
Internal current consumption (See note 3.)	390mA max. (with sensor power supply used) 200mA max. (with no sensor power supply used)	
Processing of non-used output	Open in principle	
Transmission line	Shielded twist pair cable: 500m max.	
Mass	Approx. 330g	
External connections	Removable screw terminal block (M3 x 20 poles)	

Note: 1. The renewal cycle is 1ms while in integrated value mode.

2. The sensor power supply is specified at a Ta of 25°C with an ambient temperature of 40°C or below in case of short-circuiting.

3. The internal current consumption varies with the number of channels used.

The current consumption can be reduced by disabling the sensor power supplies for unused channels.

#### 4-4 External Wiring Diagram of F/AD Conversion Module for Flow Meter

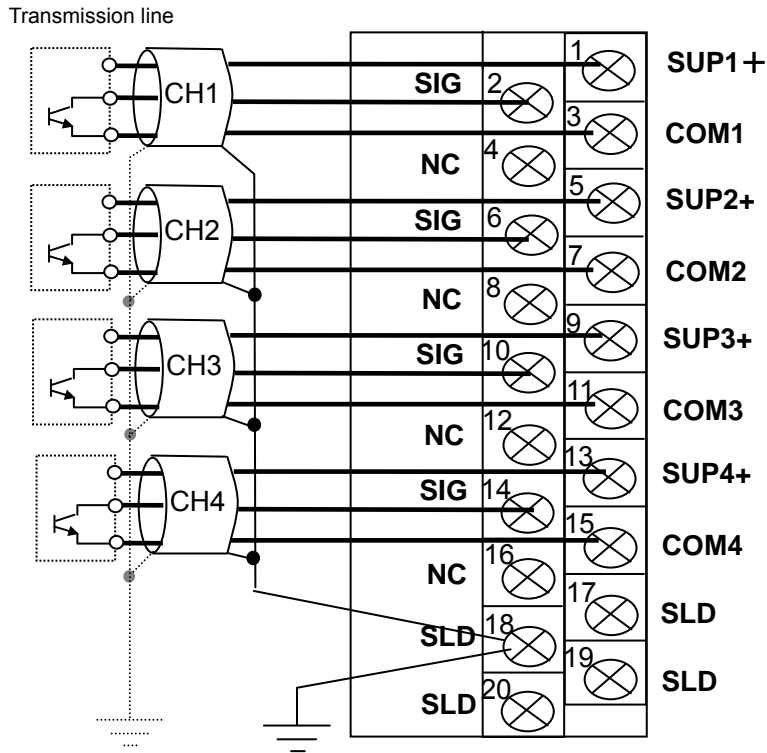

#### 5. Versions of Programming Support Tools

The following versions are required to use the module.

- Expert (D300win) V3 (NP4H-SEDBV3): V3.4.4.0 or subsequent versions
- Standard (NP4H-SWN): V2.3.5.0 or subsequent versions