

Contents

Appendix 1. Advantageous Use of Inverters (with regard to Electrical Noise) 8-2

- 1.1 Effect of inverters on other devices 8-2
 - 1.1.1 Effect on AM radios 8-2
 - 1.1.2 Effect on telephones 8-2
 - 1.1.3 Effect on proximity limit switches 8-2
 - 1.1.4 Effect on pressure sensors 8-2
 - 1.1.5 Effect on position detectors
(pulse generators; PGs, or pulse encoders) 8-2
- 1.2 Noise 8-2
 - 1.2.1 Inverter noise 8-2
 - 1.2.2 Types of noise 8-3
- 1.3 Noise prevention measures 8-5
 - 1.3.1 Noise prevention treatments prior to installation 8-5
 - 1.3.2 Implementation of noise prevention measures 8-5
 - 1.3.3 Specific examples 8-8

**Appendix 2. Effect on Insulation of General-purpose
Motor Driven with 460V Class Inverter 8-11**

- 2.1 Operating principle of inverter 8-11
 - 2.1.1 Main circuit configuration of inverter 8-11
 - 2.1.2 Control method of inverter 8-11
- 2.2 Generating mechanism of surge voltages 8-11
- 2.3 Effect of surge voltages 8-12
- 2.4 Countermeasures against surge voltages 8-12
 - 2.4.1 Method to use motors with enhanced insulation 8-12
 - 2.4.2 Method to suppress surge voltages 8-12
- 2.5 Regarding existing equipment 8-13
 - 2.5.1 In case of motor being driven with 400V class inverter 8-13
 - 2.5.2 In case of existing motor driven newly with 400V class inverter 8-13

Appendix 3. Example Calculation of Energy Savings 8-14

- 2.1 Calculating condition 8-14
- 2.2 Calculation of shaft driving power 8-14
- 2.3 Calculation of energy savings 8-14

Appendix 4. Inverter Generating Loss 8-15

Appendix 1. Advantageous Use of Inverters (with regard to Electrical Noise)

1.1 Effect of inverters on other devices

This paper describes the effect that inverters, for which the field of applications is expanding, have on electronic devices already installed and on devices installed in the same system as the inverters. Measures to counter these effects are also introduced. (Refer to 1.3.3 Specific examples for further details.)

1.1.1 Effect on AM radios

- (1) When operating an inverter, nearby AM radios may pickup noise from the inverter. (The inverter has almost no effect on FM radios or televisions)
- (2) It is considered that radios receive noise radiated from the inverter.
- (3) Measures to provide a noise filter on the power supply side of the inverter are effective.

1.1.2 Effect on telephones

- (1) When operating an inverter, telephones may pickup noise during a conversation, making it difficult to hear.
- (2) It is considered that a high-frequency leakage current radiated from the inverter and motors enters shielded telephone cables.
- (3) It is effective to commonly connect the grounding terminals of the motors and return the common grounding line to the grounding terminal of the inverter.

1.1.3 Effect on proximity limit switches

- (1) When operating an inverter, proximity limit switches (capacitance-type) may malfunction.
- (2) It is considered that malfunction occurs because the capacitance-type proximity limit switches have inferior noise immunity.
- (3) Connecting a filter to the input terminals of the inverter or changing the power supply treatment of the proximity limit switches is effective. In addition, the proximity limit switches can be changed to superior noise immunity types such as the magnetic type.

1.1.4 Effect on pressure sensors

- (1) When operating an inverter, pressure sensors may malfunction.
- (2) It is considered that malfunction occurs because noise penetrates through a grounding wire into the signal line.
- (3) It is effective to install a noise filter on the power supply side of the inverter or to change the wiring.

1.1.5 Effect on position detectors (pulse generators; PGs, or pulse encoders)

- (1) When operating an inverter, erroneous pulses from pulse converters may shift the stop position of a machine.
- (2) Erroneous pulses are liable to occur when the signal lines of the PG and power lines are bundled together.
- (3) The influence of induction noise and radiation noise can be reduced by separating the signal lines of the PG and power lines. Providing noise filters at the input and output terminals is also an effective measure.

1.2 Noise

A summary of the noise generated in inverters and its effect on devices susceptible to noise is described below.

1.2.1 Inverter noise

Figure 1 shows an outline of the inverter configuration. The inverter converts AC to DC (rectification) in a converter unit, and converts DC to AC (inversion) with 3-phase variable voltage and variable frequency. The conversion (inversion) is performed by PWM implemented by switching 6 transistors, and is used for variable speed motor control.

Switching noise is generated by the high-speed on/off switching of the 6 transistors. Noise current (i) is emitted and at each high-speed on/off switching the noise current flows through stray capacitance (C) of the inverter, cable and motor to the ground. The amount of the noise current,

$$I = C \cdot dv/dt$$

is related to the stray capacitance (C) and dv/dt (switching speed of the transistors). Further, this noise current is related to the carrier frequency since the noise current flows each time the transistors are switched on/off.

The frequency band of this noise is less than approximately 30 to 40MHz. Therefore, devices such as AM radios that use the low frequency band are affected by the noise, but FM radios and television using higher frequency than this frequency band are virtually unaffected.

Appendix 1. Advantageous Use of Inverters (with regard to Electrical Noise)

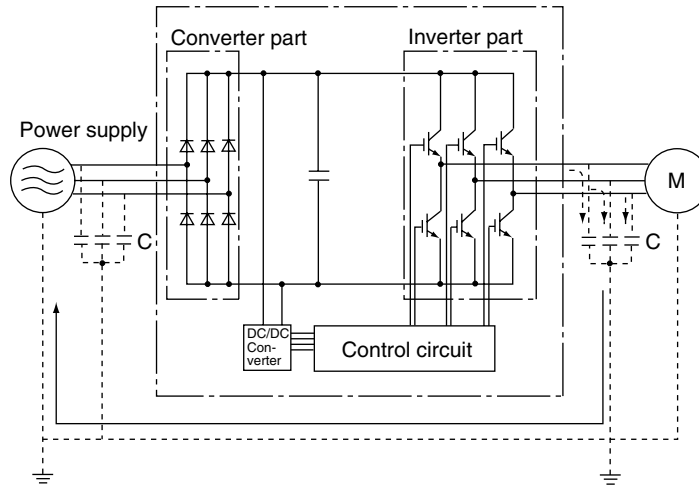

Fig. 1 Outline of inverter configuration

1.2.2 Types of noise

The noise generated in the inverter is propagated through the main circuit wiring to the power supply and the motor, and effects a wide range from the power supply transformer to the motor.

The various propagation routes are shown in Fig. 2, but these are roughly classified into 3 routes of conduction noise, induction noise and radiation noise.

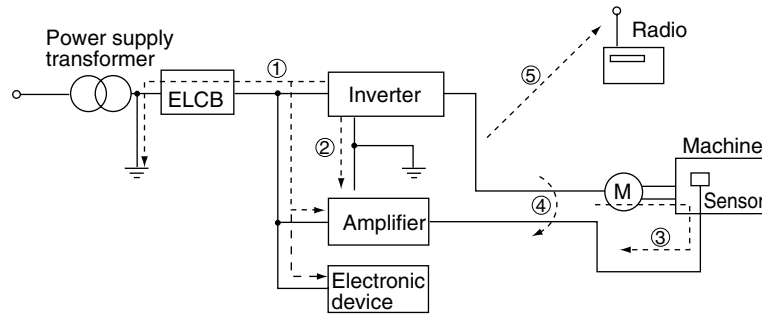

Fig. 2 Noise propagation routes

(1) Conduction noise

Conduction noise is generated in the inverter, propagates through the conductor and power supply, and effects peripheral devices of the inverter (Fig. 3) Some conduction noise ① propagates through the main circuit. If the ground lines are connected with a common connection, there is conduction through route ②. There is also noise ③ through the signal line and shielded wire.

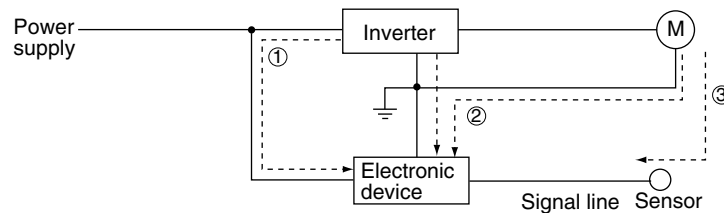

Fig. 3 Conduction noise

Appendix 1. Advantageous Use of Inverters (with regard to Electrical Noise)

(2) Induction noise

When the wire and signal lines of peripheral devices are brought close to the wires on the input and output sides of the inverter, noise is induced in the wire and signal lines of the devices by electromagnetic induction (Fig. 4) and electrostatic induction (Fig. 5). This is induction noise ④.

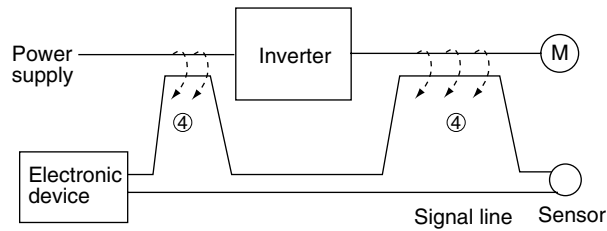

Fig. 4 Electromagnetic noise

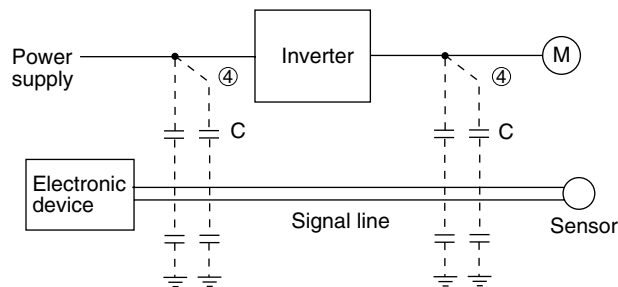

Fig. 5 Electrostatic noise

(3) Radiation noise

Noise generated in the inverter is radiated through the air from antennas consisting of wires at the input and output sides of the inverter. This noise is radiation noise ⑤ (Fig. 6). The antennas that emit radiation noise are not limited only to wires, the motor frame and panel containing the inverter may also act as antennas.

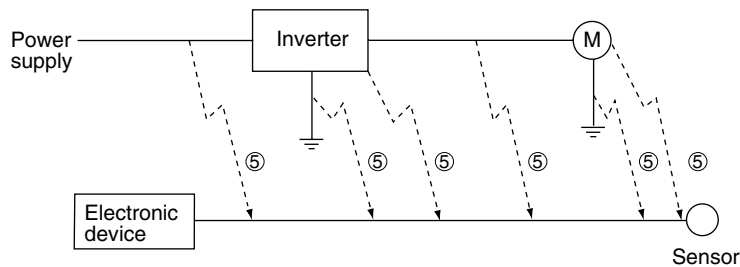

Fig. 6 Radiation noise

Appendix 1. Advantageous Use of Inverters (with regard to Electrical Noise)

1.3 Noise prevention measures

As noise prevention measures are strengthened, they become more effective. With the use of appropriate measures, noise problems may be resolved simply. Therefore, it is necessary to implement economical noise prevention measures according to the noise level and the equipment condition.

1.3.1 Noise prevention treatments prior to installation

Before inserting an inverter in a control panel or installing an inverter panel, it is necessary to consider the noise. Once noise problems occur, great expenditures of apparatuses, materials and time are required.

Noise prevention treatments prior to installation are listed below.

- ① Separation of the wiring of the main circuit and control circuit
- ② Insertion of the main circuit wiring into a metal pipe (conduit pipe)
- ③ Use of shielded wire or twisted shielded wire in the control circuit.
- ④ Implementation of appropriate grounding work and grounding wiring.

These treatments can avoid most noise problems.

1.3.2 Implementation of noise prevention measures

There are two types of noise prevention measures, those that correspond to the propagation route and those that counteract the effect of noise on the receiving side (side that is adversely affected by the noise).

The basic measure to lessen the effect of noise on the receiving side is to:

- ① Separate the main circuit wiring from the control circuit wiring, making it more difficult to receive noise.

The basic measures to lessen the effect of noise on the generating side are to:

- ② Install a noise filter to reduce the noise level.
- ③ Apply a metal conduit pipe or metal control panel to confine the noise level, and
- ④ Apply an insulated transformer for the power supply to cut off the noise propagation route.

Table 1 lists the methods for preventing the noise problems, their goals and the propagation routes.

Next, noise prevention measures are presented for the inverter drive configuration.

(1) Wiring and grounding

Separating the main circuit and control circuit as much as possible, both inside and outside the control panel, and the use of shielded wire and twisted shielded wire, makes it more difficult to receive noise and allows wiring distances to be minimized (refer to Fig. 7). Take notice that the wiring of the main circuit and control circuit does not become bundled or parallel wiring.

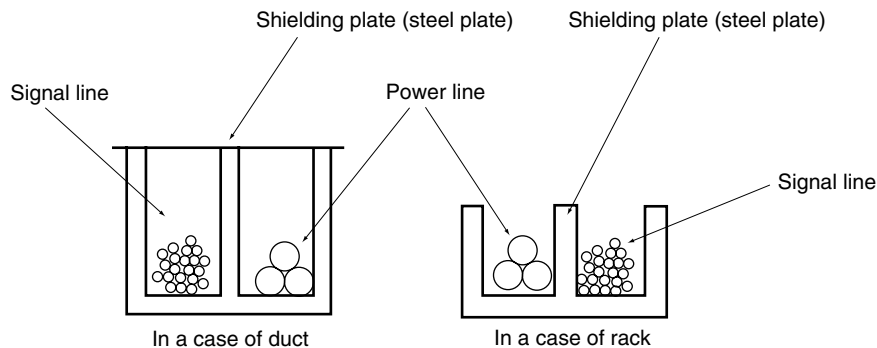

Fig. 7 Method of separating wiring

For the main circuit wiring, a metal conduit pipe is used and grounded through a grounding wiring to prevent noise propagation (refer to Fig. 8).

The shield (braided wire) of the shielded wire is securely connected to the base (common) side of the signal line at only one point to avoid the loop formation resulting from a multi-point connection (refer to Fig. 9).

The grounding is effective to not only to reduce the risk of electric shocks, but also to block noise penetration and radiation. Corresponding to the main circuit voltage, the grounding work should be No. 3 grounding work (300V AC or less) and special No. 3 grounding work (300 to 600V AC). Each ground wire is to be provided with its own ground or separately wired to a grounding point.

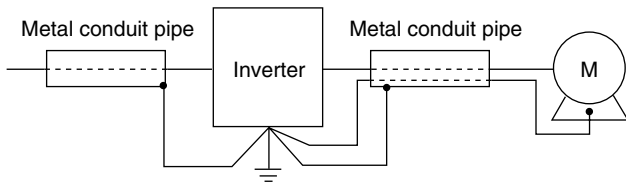

Fig. 8 Grounding of metal conduit pipe

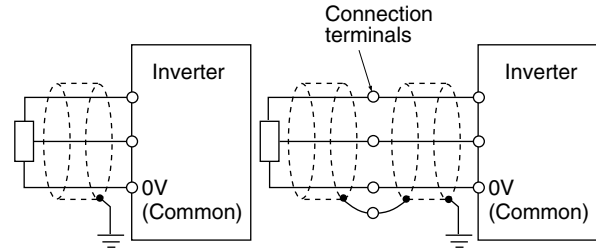

Fig. 9 Treatment of braided wire of shielded wire

Table 1 Noise prevention methods

Noise prevention method		Goal of noise prevention measure			Conduction route			
		Make it more difficult to receive noise	Cutoff noise conduction	Confine noise	Reduce noise level	Conduction noise	Induction noise	Radiation noise
Wiring and installation	Separate main circuit and control circuit	○					○	
	Minimum wiring distance	○			○		○	○
	Avoid parallel and bundled wiring	○					○	
	Use appropriate grounding	○			○	○	○	
	Use shielded wire and twisted shielded wire	○					○	○
	Use shielded cable in main circuit			○			○	○
	Use metal conduit pipe			○			○	○
Control panel	Appropriate arrangement of devices in panel	○					○	○
	Metal control panel			○			○	○
Anti-noise device	Line filter	○			○	○		○
	Insulation transformer		○			○		○
Treatment on the noise receiving side	Use passing capacitor	○					○	○
	Use ferrite core for control circuit	○			○		○	○
	Line filter	○		○		○		
Others	Separate power supply systems		○			○		
	Lower the carrier frequency				△	○	○	○

(2) Control panel

The control panel containing the inverter is generally made of metal, and this metal box can shield noise radiated from the inverter itself.

Further, when installing other electronic devices such as a programmable logic controller in the same control panel, attention should be paid to the arrangement of each device. When necessary, a noise prevention measure should be implemented, such as installing a shielding plate between the inverter and peripheral devices.

(3) Anti-noise devices

To reduce the noise propagated through the electrical circuits and the noise radiated from the main circuit wiring to the air, a line filter and power supply transformer are utilized (refer to Fig 10).

Among line filters, there are the simple type filters, such as a capacitive filter connected in parallel to the power supply line and an inductive filter connected in series to the power supply line, as well as orthodox filters (LC filters). These filters are used according to the targeted effect for reducing noise. In power supply transformers, there are common insulated transformers, shielded transformers, noise-cut transformers, etc. These transformers have different effectiveness in blocking noise propagation.

Appendix 1. Advantageous Use of Inverters (with regard to Electrical Noise)

(4) Noise prevention measures on the receiving side

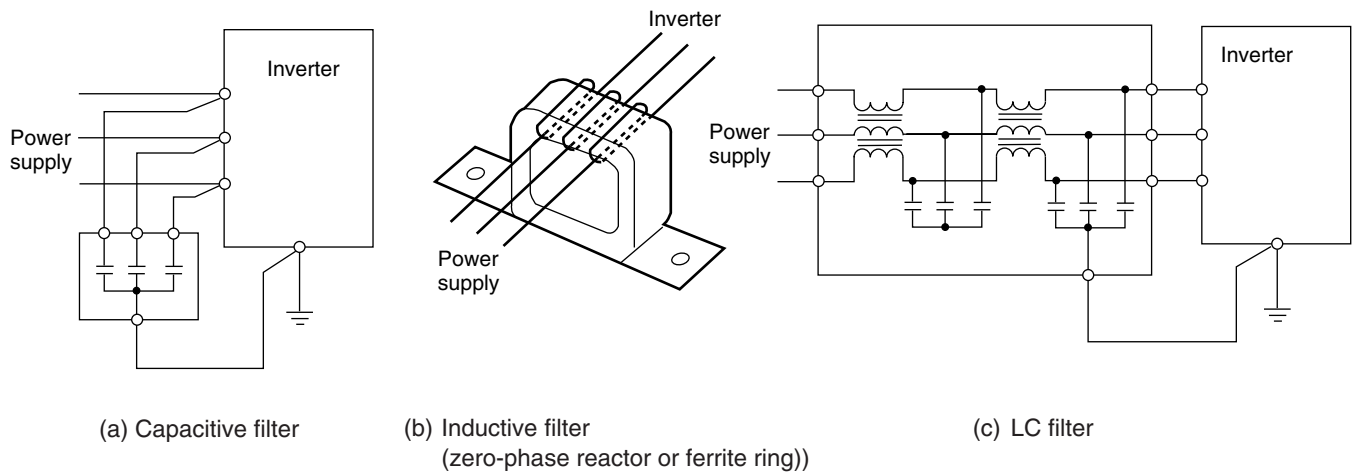

Fig. 10 Various filters and their connection methods

It is important to strengthen the noise immunity of those electronic devices installed in the same control panel as the inverter and/or located near the inverter.

Line filters and shielded or twisted shielded wire is used to block the penetration of noise in the signal lines of these devices. The following treatments are also implemented.

- ① The circuit impedance is lowered by connecting capacitors or resistors to the input and output terminals of the signal circuit in parallel.
- ② The circuit impedance for noise is increased by inserting choke coils in series in the signal circuit, or, passing the signal through ferrite core beads.

It is also effective to widen the signal base line (0 V line) or grounding line.

(5) Other

The generating (propagating) level of noise changes with the carrier frequency of the inverter, the higher the carrier frequency, the higher the generated level of noise.

In the case of an inverter for which the carrier frequency can be changed, lowering the carrier frequency can reduce the generation of electrical noise and result in a good balance with the audible noise of the motor under driving conditions.

1.3.3 Specific examples

Table 2 lists specific examples of the measures to prevent noise generated by operation of the inverter.

Table 2 Specific examples of noise prevention measures

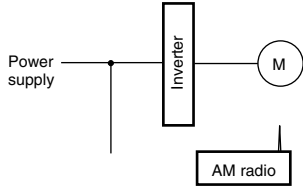
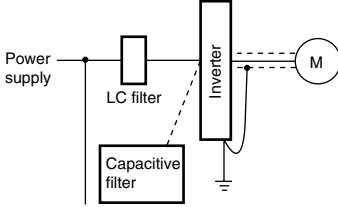
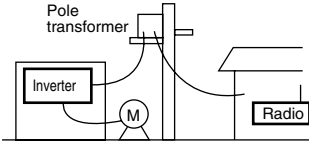
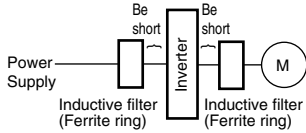
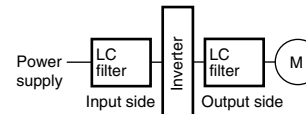
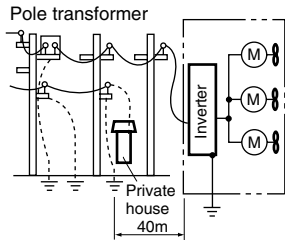
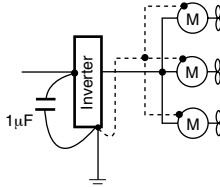
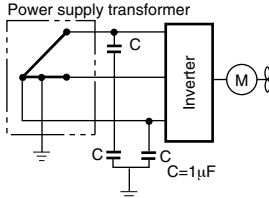
No.	Target device	Phenomena	Noise prevention measures	Notes
1	AM radio	<p>When operating an inverter, noise entered into AM radio broadcast (500 to 1500kHz).</p>  <p><Estimated cause> It is considered that the AM radio receives noise radiated from wires at the power supply and output sides of the inverter.</p>	<p>① Install an LC filter on the power supply side of the inverter. (A simple method is to install a capacitive filter.) ② Install a metal conduit wiring between the motor and inverter.</p>  <p>Note: Minimize the distance between the LC filter and inverter as much as possible (within 3ft (1m)).</p>	<p>① The radiation noise of the wiring is reduced. ② The conduction noise to the power supply side is reduced. Further, shielded wiring is used. Note: Sufficient improvement may not be expected in narrow regions such as between mountains.</p>
2	AM radio	<p>When operating an inverter, noise entered into AM radio broadcast (500 to 1500kHz).</p>  <p><Estimated cause> It is considered that the AM radio receives noise radiated from the power line at the power supply side of the inverter.</p>	<p>① Install inductive filters at the input and output sides of the inverter.</p>  <p>The number of turns of the zero-phase reactor (or ferrite ring) should be as large as possible. Further, wiring between the inverter and the zero-phase reactor (or ferrite ring) should be short as possible. (within 3ft (1m)) ② When further improvement is necessary, install LC filters.</p> 	<p>① The radiation noise of the wiring is reduced.</p>
3	Telephone (in a common private residence at a distance of 130ft (40m))	<p>When driving a ventilation fan with an inverter, noise entered a telephone in a private residence at a distance of 130ft (40m).</p>  <p><Estimated cause> A high-frequency leakage current from the inverter and motor flowed to grounded part of the telephone cable shield. During the current's return trip, it flowed through a grounded pole transformer, and noise entered the telephone by electrostatic induction.</p>	<p>① Connect the ground terminals of the motors in a common connection. Return to the inverter panel, and insert a 1μF capacitor between the input terminal of the inverter and ground.</p> 	<p>① The effect of the inductive filter and LC filter may not be expected because of sound frequency component. ② In the case of a V-connection power supply transformer in a 230V system, it is necessary to connect capacitors as shown in the following figure, because of different potentials to the ground.</p> 

Appendix 1. Advantageous Use of Inverters (with regard to Electrical Noise)

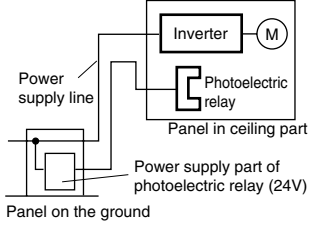
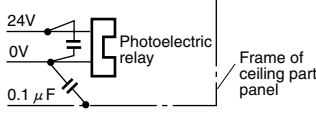
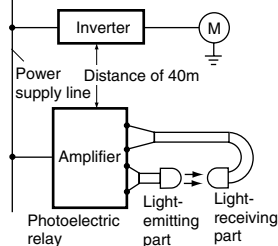
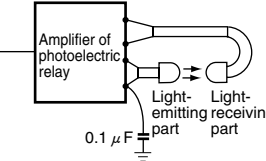
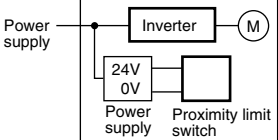
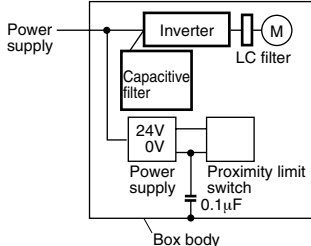
No.	Target device	Phenomena	Noise prevention measures	Notes
4	Photoelectric relay	<p>A photoelectric relay malfunctioned when the inverter was operated. [The inverter and motor are installed in the same place (for overhead traveling)]</p>  <p><Estimated cause> It is considered that induction noise entered the photoelectric relay since the inverter's input power supply line and the photoelectric relay's wiring are in parallel separated by approximately 0.98inch (25mm) over a distance of 98 to 131ft (30 to 40m). Due to conditions of the installation, these lines cannot be separated.</p>	<p>① As a temporary measure, insert a 0.1μF capacitor between the 0 V terminal of the power supply circuit in the detection unit of the overhead photoelectric relay and a frame of the overhead panel.</p>  <p>② As a permanent measure, move the 24V power supply from the ground to the overhead unit so that signals are sent to the ground side with relay contacts in the ceiling part.</p>	<p>① The wiring is separated. (by more than 11.81inch (30cm).) ② When separation is impossible, signals can be received and sent with dry contacts etc. ③ Do not wire weak-current signal lines and power lines in parallel.</p>
5	Photoelectric relay	<p>A photoelectric relay malfunctioned when the inverter was operated.</p>  <p><Estimated cause> Although the inverter and photoelectric relay are separated by a sufficient distance, since the power supplies share a common connection, it is considered that conduction noise entered through the power supply line into the photoelectric relay.</p>	<p>① Insert a 0.1μF capacitor between the output common terminal of the amplifier of the photoelectric relay and a frame.</p> 	<p>① If a weak-current circuit on the malfunctioning side is observed, the countermeasures may be simple and economical.</p>
6	Proximity limit switch (electrostatic type)	<p>A proximity limit switch malfunctioned.</p>  <p><Estimated cause> It is considered that the capacitance type proximity limit switch is susceptible to conduction and radiation noise because of its low noise immunity.</p>	<p>① Install an LC filter on the output side of the inverter. ② Install a capacitive filter on the input side of the inverter. ③ Ground the 0 V (common) line of the DC power supply of the proximity limit switch through a capacitor to the box body of the machine.</p> 	<p>① Noise generated in the inverter is reduced. ② The switch is superseded by a proximity limit switch of superior noise immunity (such as a magnetic type) .</p>

Chapter 8

Appendix 1. Advantageous Use of Inverters (with regard to Electrical Noise)

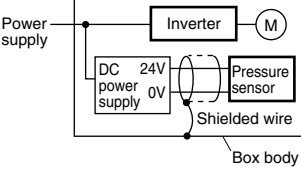
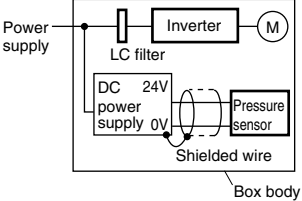
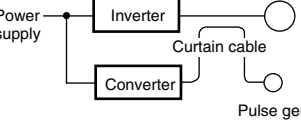
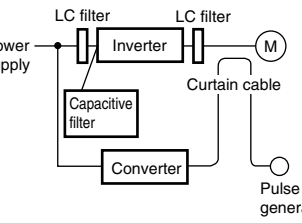
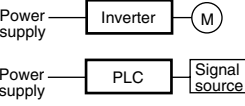
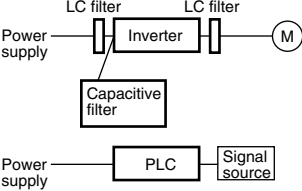
No.	Target device	Phenomena	Noise prevention measures	Notes
7	Pressure sensor	<p>A pressure sensor malfunctioned.</p>  <p><Estimated cause> It is considered that the pressure sensor signal malfunction was due to noise that came from the box body and traveled through the shield of the shielded wire.</p>	<p>① Install an LC filter on the input side of the inverter. ② Connect the shield of the shielded wire of the pressure sensor to the 0 V line (common) of the pressure sensor, changing the original connection.</p> 	<p>① The shielded parts of shield wire for sensor signals are connected to a common point in the system. ② Conduction noise from the inverter is reduced.</p>
8	Position detector (pulse generator: PG)	<p>Erroneous-pulse outputs from a pulse converter caused a shift in the stop position of a crane.</p>  <p><Estimated cause> It is considered that erroneous pulses are output by induction noise since the power line of the motor and the signal line of the PG are bundled in a lump.</p>	<p>① Install an LC filter and a capacitive filter on the input side of the inverter. ② Install an LC filter on the output side of the inverter.</p> 	<p>① This is an example of a measure where the power line and signal line cannot be separated. ② Induction noise and radiation noise on the output side of the inverter are reduced.</p>
9	Programmable logic controller (PLC)	<p>The PLC program sometimes malfunctions.</p>  <p><Estimated cause> Since the power supply system is the same for the PLC and inverter, it is considered that noise enters the PLC through the power supply.</p>	<p>① Install a capacitive filter and an LC filter on the input side of the inverter. ② Install an LC filter on the output side of the inverter. ③ Lower the carrier frequency of the inverter.</p> 	<p>① Total conduction noise and induction noise in the electric line are reduced.</p>

Appendix 2. Effect on Insulation of General-purpose Motor Driven with 460V Class Inverter

Excerpt from Technical Document of
the Japan Electrical Manufacturers'
Association (JEMA) (March, 1995)

Appendix 2. Effect on Insulation of General-purpose Motor Driven with 460V Class Inverter

Introduction

When an inverter drives a motor, surge voltages generated by switching the inverter elements are superimposed on the inverter output voltage and applied to the motor terminals. If the surge voltages are too high they may have an effect on the motor insulation and some cases have resulted in damage.

For preventing such cases this document describes the generating mechanism of the surge voltages and countermeasures against them.

2.1 Operating principle of inverter

2.1.1 Main circuit configuration of inverter

The main circuit of an inverter is configured with a converter part and an inverter part. The former part rectifies a commercial power source voltage and eliminates resulting ripple components, and the latter part converts DC voltage to AC voltage through a 3-phase bridge circuit composed of switching elements like transistors. (Refer to Fig. 1)

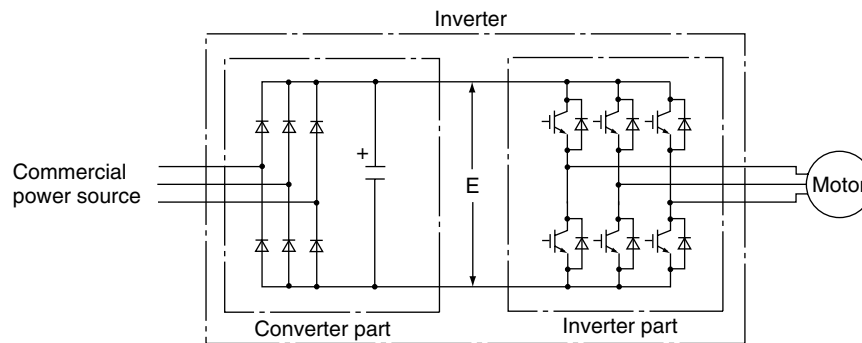

Fig. 1 Main circuit configuration of inverter

2.1.2 Control method of inverter

The PWM (Pulse Width Modulation) control is commonly adopted in general-purpose inverters. This method generates multiple switching pulses in one output cycle because both the output voltage and frequency are simultaneously controlled in the inverter part. The output voltage control is carried out by varying the pulse width while the pulse magnitude is kept constant.

The number of switching pulses generated in one second is designated as a carrier frequency and is normally high up to 0.7 to 16kHz. So transistors capable of high-speed switching (IGBT, etc.) are used for inverter elements.

2.2 Generating mechanism of surge voltages

As the inverter rectifies a commercial power source voltage and smoothes into a DC voltage, the magnitude E of the DC voltage becomes about $\sqrt{2}$ times of that of the source voltage (about 620V in case of an input voltage of 440V AC). The peak value of the output voltage is usually close to this DC voltage value.

But, as there exists inductance (L) and stray capacitance (C) in wiring between the inverter and the motor, the voltage variation due to switching the inverter elements causes a surge voltage originating in LC resonance and results in the addition of a high voltage to the motor terminals. (Refer to Fig.2)

This voltage sometimes reaches up to about twice of the inverter DC voltage ($620V \times 2 =$ about 1,200V) depending on a switching speed of the inverter elements and a wiring condition.

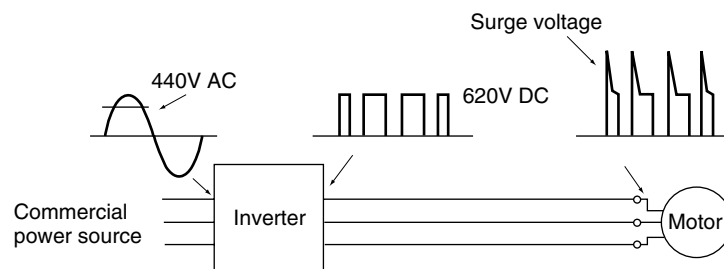
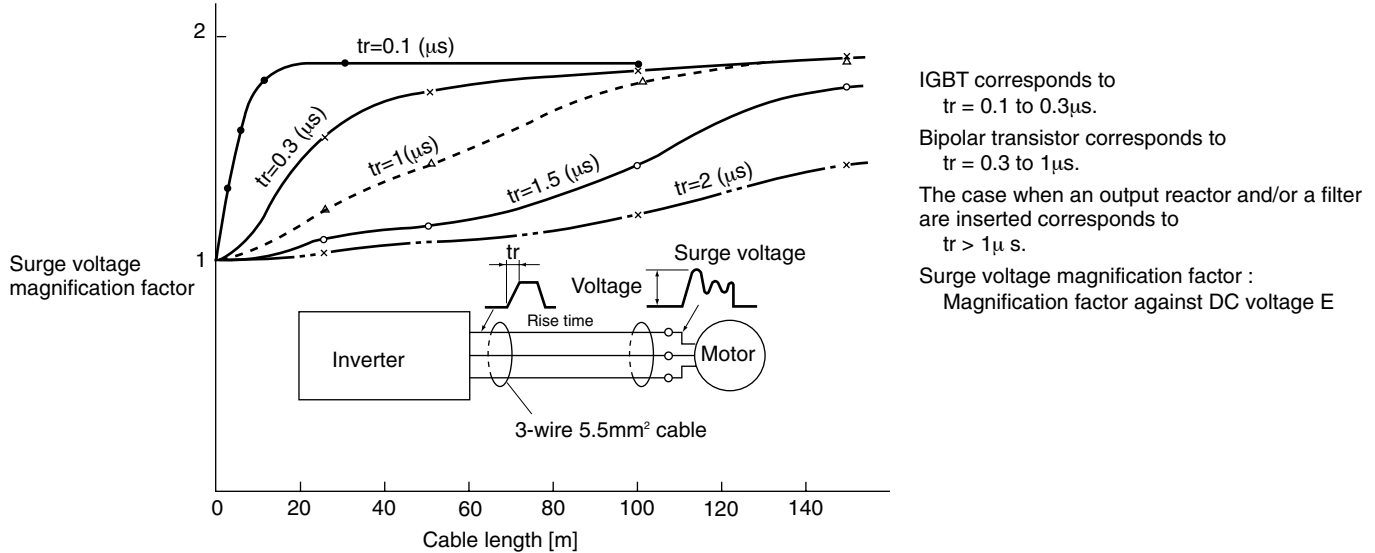

Fig. 2 Voltage wave shapes of individual positions

A measured example in Fig. 3 illustrates relation of a peak value of the motor terminal voltage with a wiring length between the inverter and the motor.

From this it can be confirmed that the peak value of the motor terminal voltage ascends as the wiring length increases and becomes saturated at about twice of the inverter DC voltage.

Besides the shorter a pulse rise time becomes, the higher the motor terminal voltage rises even in case of a short wiring length.



Excerpt from [J. IEE Japan, Vol. 107, No. 7, 1987]

Fig. 3 Measured example of wiring length and peak value of motor terminal voltage

2.3 Effect of surge voltages

The surge voltages originating in LC resonance of wiring may be applied to the motor input terminals and depending on their magnitude sometimes cause damage to the motor insulation.

When the motor is driven with a 230V class inverter, as for dielectric strength of the insulation it is no problem that the peak value at the motor terminal voltage increases twice due to the surge voltages, since the DC voltage is only about 300V.

But in case of a 400V class inverter the DC voltage becomes about 600V and depending on wiring length the surge voltages may highly rise and sometimes result in damage to the insulation.

2.4 Countermeasures against surge voltages

The following methods are countermeasures against damage to the motor insulation by the surge voltages in case of a motor driven with a 460V class inverter.

2.4.1 Method to use motors with enhanced insulation

Enhanced insulation of a motor winding allows its surge proof strength to be improved.

2.4.2 Method to suppress surge voltages

There are two methods for suppressing the surge voltages, one is to reduce the voltage rising and another is to reduce the voltage peak value.

Appendix 2. Effect on Insulation of General-purpose Motor Driven with 460V Class Inverter

(1) Output reactor

If wiring length is relatively short the surge voltages can be suppressed by reducing the voltage rising (dv/dt) with installation of an AC reactor on the output side of the inverter. (Refer to Fig. 4 (1)) However, if the wiring length becomes long, suppressing the peak voltage due to surge voltage may be difficult.

(2) Output filter

Installing a filter on the output side of the inverter allows a peak value of the motor terminal voltage to be reduced. (Refer to Fig. 4 (2))

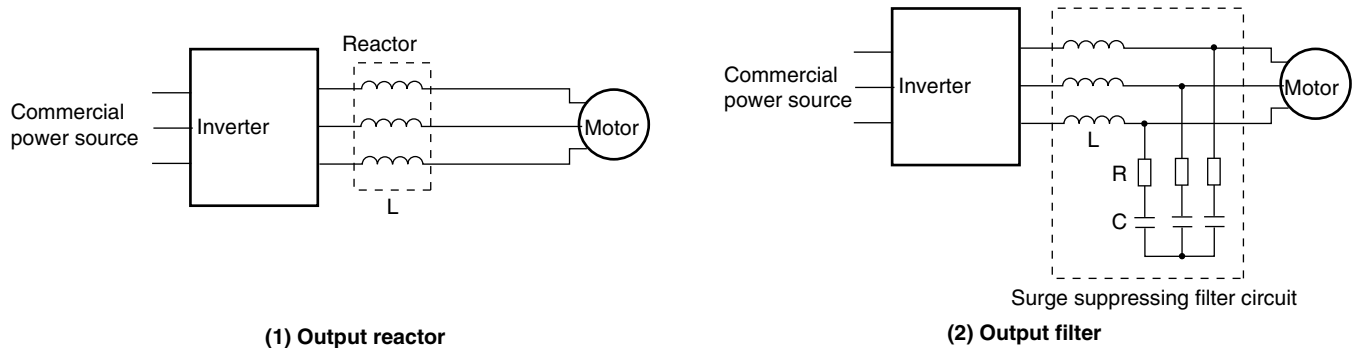

Fig. 4 Method to suppress surge voltage

2.5 Regarding existing equipment

2.5.1 In case of motor being driven with 400V class inverter

The last five years survey on motor insulation damage due to the surge voltages originating from switching of inverter elements shows that the damage incidence is 0.013% under the surge voltage condition of over 1,100V and most of the damage occurs in several months after commissioning of the inverter. Therefore there seems to be little probability of occurrence of motor insulation damage after a lapse of several months of commissioning.

2.5.2 In case of existing motor driven newly with 400V class inverter

We recommend to suppress the surge voltages with the method of 2.4.2.

Appendix 3. Example Calculation of Energy Savings

The energy saving that results from use of an inverter is calculated based on a specific calculation result (in the case of a fan and pump). The Q-P characteristic curve corresponding to damper use in Fig. 1 changes depending on the motor capacity and manufacturer. Therefore, characteristic curves should be obtained individually when performing a detailed calculation.

2.1 Calculating condition

[Use]

- Fan for air conditioning

[Usage period]

- 250 days / year (24 hours / day)

[Reduced rate of air flow with damper]

- In accordance with general output characteristics (Q-P curve) in Fig.1

[Reducing rate of air flow with an inverter (frequency)]

- 60Hz → 40Hz

[Electric power at maximum air flow rate : P_0 [kW]]

- $P_0 = \text{Applied motor [kW]} \times 1 / \text{Motor efficiency} \rightarrow P_0$
 $= \text{Applied motor [kW]} \times 1/0.9$

<In a case of a motor of 37kW>

- $P_0 = 37 \times 1/0.9$
 $= 41.1 \text{ kW}$

[Power rate per 1 kWh : M_2 [US\$]]

- Suppose US\$0.04/kWh

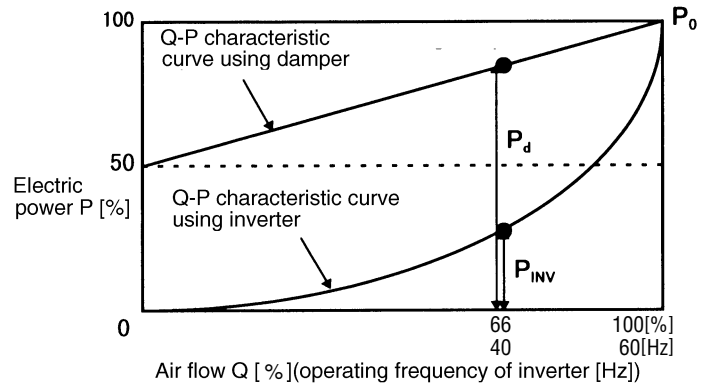

Fig.1 Q-P characteristic curve

2.2 Calculation of shaft driving power

[Shaft driving power with damper control : P_d]

$$P_d = ((50+50 \times (40/60))/100) \times P_0$$

$$= 0.833 P_0 \text{ [kW]}$$

[Shaft driving power with inverter control : P_{INV}]

$$P_{INV} = (40/60)^3 \times P_0$$

$$= 0.296 \times P_0 \text{ [kW]}$$

2.3 Calculation of energy savings

A specific example of the energy savings is calculated with the following formula.

<Formula>

- $M_1 = (P_d - P_{INV}) \times T \times M_2$ [US\$/year]
 where M_2 : Electricity bill of the energy saving [US\$/year]
 T : Operating time per year [h]
 M_2 : Power rate per 1 kWh [US\$]

■ Calculation example

- $M_1 = (P_d - P_{INV}) \times T \times M_2$ [US\$/year]
 $= (0.833-0.296) \times P_0 \times T \times M_2$
 $= 0.537 \times 41.1 \times (250 \times 24) \times 0.04$
 $= 5,297$ [US\$/year]

Therefore, energy savings of approximately US\$18,500/year are obtained.

Appendix 4. Inverter Generating Loss

Inverter generating loss

Power supply voltage	Nominal applied motor [HP]	Inverter type		Generating loss [W]			
		G11S series	P11S series	G11S series		P11S series	
				Carrier frequency (fc)		Carrier frequency (fc)	
				Low (2kHz)	High (15kHz)	Low (2kHz)	High (15kHz)
Three-phase 230V	1/4	FRNF25G11S-2UX	-	25	30	-	-
	1/2	FRNF50G11S-2UX		35	45		
	1	FRN001G11S-2UX		50	60		
	2	FRN002G11S-2UX		80	110		
	3	FRN003G11S-2UX		110	140		
	5	FRN005G11S-2UX		170	210		
	7.5	FRN007G11S-2UX	FRN007P11S-2UX	240	320	210	280
	10	FRN010G11S-2UX	FRN010P11S-2UX	300	415	290	370
	15	FRN015G11S-2UX	FRN015P11S-2UX	450	620	410	550
	20	FRN020G11S-2UX	FRN020P11S-2UX	540	720	500	670
	25	FRN025G11S-2UX	FRN025P11S-2UX	670	890	630	840
	30	FRN030G11S-2UX	FRN030P11S-2UX	880	1160	770	1030
	40	FRN040G11S-2UX	FRN040P11S-2UX	1150	1400	1250	1400 *1)
	50	FRN050G11S-2UX	FRN050P11S-2UX	1400	1750	1550	1700 *1)
	60	FRN060G11S-2UX	FRN060P11S-2UX	1700	2050	1800	2050 *1)
	75	FRN075G11S-2UX	FRN075P11S-2UX	1950	2400	2100	2350 *1)
100	FRN100G11S-2UX	FRN100P11S-2UX	2750	3100 *1)	2800	3100 *1)	
125	FRN125G11S-2UX	FRN125P11S-2UX	3250	3650 *1)	3350	3500 *2)	
150	-	FRN150P11S-2UX	-	-	3950	4150 *2)	
Three-phase 460V	1/2	FRNF50G11S-4UX	-	35	60	-	-
	1	FRN001G11S-4UX		45	85		
	2	FRN002G11S-4UX		60	110		
	3	FRN003G11S-4UX		80	150		
	5	FRN005G11S-4UX		130	230		
	7.5	FRN007G11S-4UX	FRN007P11S-4UX	170	300	160	290
	10	FRN010G11S-4UX	FRN010P11S-4UX	230	400	210	370
	15	FRN015G11S-4UX	FRN015P11S-4UX	300	520	300	520
	20	FRN020G11S-4UX	FRN020P11S-4UX	360	610	360	610
	25	FRN025G11S-4UX	FRN025P11S-4UX	460	770	460	770
	30	FRN030G11S-4UX	FRN030P11S-4UX	550	900	530	870
	40	FRN040G11S-4UX	FRN040P11S-4UX	900	1400	1100	1400 *1)
	50	FRN050G11S-4UX	FRN050P11S-4UX	1000	1700	1300	1600 *1)
	60	FRN060G11S-4UX	FRN060P11S-4UX	1150	1950	1450	1900 *1)
	75	FRN075G11S-4UX	FRN075P11S-4UX	1400	2300	1700	2200 *1)
	100	FRN100G11S-4UX	FRN100P11S-4UX	2000	2800 *1)	2050	2700 *1)
	125	FRN125G11S-4UX	FRN125P11S-4UX	2350	3250 *1)	2650	2950 *2)
	150	FRN150G11S-4UX	FRN150P11S-4UX	2600	3600 *1)	2950	3300 *2)
	200	FRN200G11S-4UX	FRN200P11S-4UX	2950	4150 *1)	3300	3750 *2)
	250	FRN250G11S-4UX	FRN250P11S-4UX	3450	4900 *1)	3900	4450 *2)
300	FRN300G11S-4UX	FRN300P11S-4UX	3950	5750 *1)	4450	5150 *2)	
350	FRN350G11S-4UX	FRN350P11S-4UX	4400	6350 *1)	4950	5700 *2)	
400	FRN400G11S-4UX	FRN400P11S-4UX	5550	8050 *1)	5800	6700 *2)	
450	FRN450G11S-4UX	FRN450P11S-4UX	6250	9000 *1)	6500	7550 *2)	
500	FRN500G11S-4UX	FRN500P11S-4UX	6950	10200 *1)	7250	8450 *2)	
600	FRN600G11S-4UX	FRN600P11S-4UX	7850	11400 *1)	8250	9550 *2)	
700	-	FRN700P11S-4UX	-	-	9200	10700 *2)	
800	-	FRN800P11S-4UX	-	-	10400	12100 *2)	

NOTES: *1) fc=10kHz

*2) fc=6kHz

MEMO

