

Contents

1. Inverter Input Current	3-2
2. Circuit Breakers and Magnetic Contactors	3-3
3. Wire Size	3-4
3.1 FRENIC5000G11S/P11S Series	3-4
3.2 Allowable current of insulation wire	3-8
4. Braking Unit and Braking Resistor	3-10
5. Braking Unit and Braking Resistor (10% ED)	3-12
6. Rated Sensitive Current of GFCI	3-14
7. Input Circuit Noise Filter (EMC Compliance Filter)	3-15
8. Output Circuit Noise Filter (OFL- □□ -2/4)	3-16
9. Output Circuit Noise Filter (OFL- □□ -4A)	3-18
10. DC REACTOR (DCR)	3-20
11. AC Reactor (ACR)	3-21
12. Ferrite Ring for Reducing Radio Noise (ACL)	3-23
13. Power Regenerative PWM Converter (RHC)	3-23

Chapter 3

1. Inverter input current

1. Inverter Input Current

■ This section describes selecting peripheral devices and cables.

Table 3.1 Various current value through inverter

Power supply voltage	Nominal applied motor [HP]	50Hz, 200V (400V, 100V)					60Hz, 220V (440V)				
		Input effective value current [A]		DC link circuit current [A]	Braking resistor circuit current [A]		Input effective value current [A]		DC link circuit current [A]	Braking resistor circuit current [A]	
		With DCR	Without reactor		G11S series	P11S series	With DCR	Without reactor		G11S series	P11S series
Three-phase 230V	1/4	0.94	1.8	1.1	1.2	-	0.84	1.7	1.0	1.2	-
	1/2	1.6	3.4	2.0	1.2		1.4	3.2	1.7	1.2	
	1	3.1	6.4	3.8	1.6		2.7	6.2	3.3	1.6	
	2	5.7	11.1	7.0	3.6		5.1	10.6	6.2	3.6	
	3	8.3	16.1	10	3.5		7.5	15.5	9.2	3.5	
	5	14.0	25.5	17	4.1		12.5	24.2	15	4.1	
	7.5	19.7	40.8	24	6.4	3.5	16.9	36.2	21	6.4	3.5
	10	26.9	52.6	33	6.1	5.3	24.0	46.6	29	6.1	5.3
	15	39.0	76.9	48	9.1	5.1	34.7	67.7	42	9.1	5.1
	20	54	98	66	11	7.2	48	87	59	11	7.2
	25	66	117	81	14	9.3	59	104	72	14	9.3
	30	78	136	96	15	11	70	123	86	15	11
	40	109	168	133	19	19	99	149	121	19	19
	50	135	204	165	25	19	122	181	149	25	19
	60	163	243	200	30	25	148	217	181	30	25
75	199	291	244	37	30	182	262	223	37	30	
100	272	-	333	48	37	247	-	303	48	37	
125	327		400	61	48	296		363	61	48	
150	400		490	-	61	364		446	-	61	
Three-phase 460V	1/2	0.82	1.8	1.0	0.8	-	0.73	1.7	0.9	0.8	-
	1	1.5	3.5	1.8	1.1		1.4	3.4	1.7	1.1	
	2	2.9	6.2	3.6	1.8		2.6	6.1	3.2	1.8	
	3	4.2	9.2	5.1	1.8		3.8	9.0	4.7	1.8	
	5	7.1	14.9	8.7	2.1		6.3	14.2	7.7	2.1	
	7.5	10.0	21.5	12	3.2	1.8	8.3	19.0	10	3.2	1.8
	10	13.5	27.9	17	3.1	2.7	12.1	24.6	15	3.1	2.7
	15	19.8	39.1	24	4.5	2.5	17.7	34.5	22	4.5	2.5
	20	26.8	50.5	32	5.7	3.6	24	44	29	5.7	3.6
	25	33.2	59.9	40	7.2	4.6	29	53	36	7.2	4.6
	30	39.3	69.3	48	7.7	5.7	35	62	43	7.7	5.7
	40	54	86	66	10	10	49	76	60	10	10
	50	67	104	82	12	10	61	92	75	12	10
	60	81	124	99	15	12	74	111	91	15	12
	75	100	150	122	19	15	91	134	111	19	15
	100	134	-	164	24	19	122	-	149	24	19
	125	160		196	31	24	146		179	31	24
	150	196		240	34	31	178		218	34	31
	200	232		284	41	34	211		258	41	34
	250	282		345	50	41	256		314	50	41
300	352	431		62	50	320	392		62	50	
350	385	472		71	62	350	429		71	62	
400	491	601		100	71	446	546		100	71	
450	552	676		100	100	502	615		100	100	
500	624	764		124	100	567	694		124	100	
600	704	862	124	124	640	784	124	124			
700	792	970	-	124	720	882	-	124			
800	880	1078	-	124	800	980	-	124			

NOTE: • The inverter efficiency is calculated using individual value by capacity. The input effective value current is obtained for following conditions:

[30HP or smaller]

• Power source capacity : 500kVA Power source impedance : 2.5%

[40HP or larger]

• Power source capacity and impedance are calculated using values corresponding to Fuji's recommended capacity.

• For different power voltages such as 230V or 380V, input current is in inverse proportion to the power voltage.

2. Circuit Breakers and Magnetic Contactors

Table 3.2 Circuit breakers and Magnetic contactors

Power supply voltage	Nominal applied motor [HP]	Inverter type		MCCB, GFCI Rated current [A]		MC1 (for input circuit)		MC2 (for output circuit)		
		G11S series	P11S series	With DCR	Without reactor	With DCR	Without reactor	G11S series	P11S series	
Three-phase 230V	1/4	FRNF25G11S-2UX	-	5	5	SC-05	SC-05	SC-05	-	
	1/2	FRNF50G11S-2UX								
	1	FRN001G11S-2UX								
	2	FRN002G11S-2UX								
	3	FRN003G11S-2UX								
	5	FRN005G11S-2UX	FRN007P11S-2UX	20	30	SC-5-1	SC-N1	SC-4-0	SC-4-0	
	7.5	FRN007G11S-2UX		30	50					
	10	FRN010G11S-2UX		FRN010P11S-2UX	40	75	SC-5-1	SC-N2	SC-N1	SC-5-1
	15	FRN015G11S-2UX		FRN015P11S-2UX	50	100	SC-N1	SC-N2S		SC-N1
	20	FRN020G11S-2UX		FRN020P11S-2UX	75	125	SC-N2	SC-N3	SC-N2	SC-N2
	25	FRN025G11S-2UX		FRN025P11S-2UX	100	150	SC-N2S	SC-N4	SC-N2S	SC-N2S
	30	FRN030G11S-2UX		FRN030P11S-2UX		175		SC-N5	SC-N3	SC-N2S
	40	FRN040G11S-2UX		FRN040P11S-2UX	150	200	SC-N4	SC-N7	SC-N4	SC-N4
	50	FRN050G11S-2UX		FRN050P11S-2UX	175	250	SC-N5	SC-N8	SC-N5	SC-N5
	60	FRN060G11S-2UX		FRN060P11S-2UX	200	300	SC-N7		SC-N7	SC-N7
	75	FRN075G11S-2UX		FRN075P11S-2UX	250	350	SC-N8	SC-N11	SC-N8	SC-N8
100	FRN100G11S-2UX	FRN100P11S-2UX		350	-	SC-N11	-	SC-N10	SC-N10	
125	FRN125G11S-2UX	FRN125P11S-2UX		400		SC-N11		SC-N11	SC-N11	
150	-	FRN150P11S-2UX		500		SC-N12		-	SC-N12	
Three-phase 460V	1/2	FRNF50G11S-4UX		-	5	5	SC-05	SC-05	SC-05	-
	1	FRN001G11S-4UX								
	2	FRN002G11S-4UX								
	3	FRN003G11S-4UX								
	5	FRN005G11S-4UX								
	7.5	FRN007G11S-4UX	FRN007P11S-4UX	15	30	SC-5-1	SC-4-0	SC-4-0	SC-4-0	
	10	FRN010G11S-4UX	FRN010P11S-4UX	20	40		SC-5-1			
	15	FRN015G11S-4UX	FRN015P11S-4UX	30	50	SC-5-1	SC-N1	SC-4-0	SC-4-0	
	20	FRN020G11S-4UX	FRN020P11S-4UX	40	60		SC-5-1	SC-N1	SC-5-1	SC-5-1
	25	FRN025G11S-4UX	FRN025P11S-4UX	50	75	SC-N1	SC-N2	SC-N1	SC-N1	
	30	FRN030G11S-4UX	FRN030P11S-4UX		100		SC-N2S			
	40	FRN040G11S-4UX	FRN040P11S-4UX	75	125	SC-N2	SC-N3	SC-N2	SC-N2	
	50	FRN050G11S-4UX	FRN050P11S-4UX	100		SC-N2S	SC-N4	SC-N2S	SC-N2S	
	60	FRN060G11S-4UX	FRN060P11S-4UX	125	150	SC-N3	SC-N4	SC-N3	SC-N3	
	75	FRN075G11S-4UX	FRN075P11S-4UX		200		SC-N3	SC-N5	SC-N4	SC-N4
	100	FRN100G11S-4UX	FRN100P11S-4UX	175	-	SC-N4	-	SC-N5	SC-N5	
	125	FRN125G11S-4UX	FRN125P11S-4UX	200		SC-N7		SC-N7	SC-N7	
	150	FRN150G11S-4UX	FRN150P11S-4UX	250		SC-N8		SC-N8	SC-N8	
	200	FRN200G11S-4UX	FRN200P11S-4UX	300		SC-N11		SC-N11	SC-N11	
	250	FRN250G11S-4UX	FRN250P11S-4UX	350		SC-N12		SC-N12	SC-N12	
	300	FRN300G11S-4UX	FRN300P11S-4UX	500		SC-N14		-	SC-N14	SC-N14
350	FRN350G11S-4UX	FRN350P11S-4UX	500							
400	FRN400G11S-4UX	FRN400P11S-4UX	600	800		SC-N16		-	SC-N16	
450	FRN450G11S-4UX	FRN450P11S-4UX	1200							
500	FRN500G11S-4UX	FRN500P11S-4UX								
600	FRN600G11S-4UX	FRN600P11S-4UX	-	SC-N16	-	-	SC-N16			
700	-	FRN700P11S-4UX								
800	-	FRN800P11S-4UX								

NOTES: For the MCCB and GFCI types, the rated current values recommended for 50°C (122°F) or lower panel inside temperature are shown. Select an actual type according to the facility short-circuit interrupting capacity.

Chapter 3
3. Wire Size

3. Wire Size

3.1 FRENIC500G11S/P11S Series

(a) Under the 50°C (122°F) or lower panel inside temperature

Table 3.3 (a) Wire size (50°C (122°F))

Power supply voltage	Nominal applied motor [HP]	Inverter type		Recommended wire size [mm ²]											
				Input circuit [L1/R, L2/S, L3/T]					Output circuit [U, V, W]						
		G11S series	P11S series	With DCR			Without reactor			G11S series					
				Allowable temp.*1)			Current	Allowable temp.*1)			Current	Allowable temp.*1)			
60°C (140°F)	75°C (167°F)	90°C (194°F)	[A]	60°C (140°F)	75°C (167°F)	90°C (194°F)	[A]	60°C (140°F)	75°C (167°F)	90°C (194°F)	[A]				
Three-phase 230V	1/4	FRNF25G11S-2UX	-	2.0	2.0	2.0	0.94	2.0	2.0	2.0	1.8	2.0	2.0	2.0	1.5
	1/2	FRNF50G11S-2UX					1.6				3.4				3
	1	FRN001G11S-2UX					3.1				6.4				5
	2	FRN002G11S-2UX					5.7				11.1				8
	3	FRN003G11S-2UX					8.3				16.1				11
	5	FRN005G11S-2UX					14				25.5				17
	7.5	FRN007G11S-2UX	FRN007P11S-2UX	3.5	19.7	14	5.5	3.5	40.8	5.5	3.5	25			
	10	FRN010G11S-2UX	FRN010P11S-2UX	5.5	3.5	26.9	-	8	5.5	52.6	8	3.5	3.5	33	
	15	FRN015G11S-2UX	FRN015P11S-2UX	14	5.5	3.5	39	-	14	14	76.9	14	8	5.5	46
	20	FRN020G11S-2UX	FRN020P11S-2UX	22	8	5.5	54	-	22	14	98.5	22	8	8	59
	25	FRN025G11S-2UX	FRN025P11S-2UX	-	14	8	66.2	-	38	22	117	-	14	14	74
	30	FRN030G11S-2UX	FRN030P11S-2UX	-	14	14	78.8	-	38	38	136	-	14	14	87
	40	FRN040G11S-2UX	FRN040P11S-2UX	60	38	22	109	-	60	38	168	60	38	22	115
	50	-	FRN050P11S-2UX	-	38	38	135	-	60	60	204	100	38	38	145
	60	FRN050G11S-2UX	-	100	-	60	38	163	-	100	60	243	-	60	38
75	FRN075G11S-2UX	FRN075P11S-2UX	-	100	60	199	-	100	100	291	-	100	60	215	
100	-	FRN100P11S-2UX	-	100	100	272	-	-	-	-	-	150	100	283	
125	FRN100G11S-2UX	-	-	150	100	327	-	-	-	-	-	150	150	346	
150	FRN125G11S-2UX	FRN125P11S-2UX	-	150	100	400	-	-	-	-	-	-	-	-	
Three-phase 460V	1/2	FRNF50G11S-4UX	-	2.0	2.0	2.0	0.82	2.0	2.0	2.0	1.8	2.0	2.0	2.0	1.5
	1	FRN001G11S-4UX					1.5				3.5				2.5
	2	FRN002G11S-4UX					2.9				6.2				3.7
	3	FRN003G11S-4UX					4.2				9.2				5.5
	5	FRN005G11S-4UX					7.1				14.9				9
	7.5	FRN007G11S-4UX					FRN007P11S-4UX				10				5.5
	10	FRN010G11S-4UX	FRN010P11S-4UX	13.5	5.5	3.5	27.9	3.5	18						
	15	FRN015G11S-4UX	FRN015P11S-4UX	3.5	19.8	14	5.5	3.5	39.1	5.5	24				
	20	FRN020G11S-4UX	FRN020P11S-4UX	5.5	3.5	26.8	14	8	5.5	50.3	8	3.5	30		
	25	FRN025G11S-4UX	FRN025P11S-4UX	8	5.5	3.5	33.2	22	14	8	59.9	14	5.5	3.5	39
	30	FRN030G11S-4UX	FRN030P11S-4UX	14	5.5	3.5	39.3	-	14	8	69.3	14	8	5.5	45
	40	FRN040G11S-4UX	FRN040P11S-4UX	22	8	5.5	54	-	22	14	86	22	14	8	60
	50	FRN050G11S-4UX	FRN050P11S-4UX	38	14	8	67	60	22	22	104	38	14	14	75
	60	FRN060G11S-4UX	FRN060P11S-4UX	38	22	14	81	60	38	22	124	38	22	14	91
	75	FRN075G11S-4UX	FRN075P11S-4UX	60	22	14	100	-	60	38	150	60	38	22	112
	100	-	FRN100P11S-4UX	-	38	38	134	-	-	-	-	100	60	38	150
	125	FRN100G11S-4UX	-	100	-	60	38	160	-	-	-	-	60	38	176
	150	FRN125G11S-4UX	FRN125P11S-4UX	-	60	60	196	-	-	-	-	-	100	60	210
	200	FRN200G11S-4UX	FRN200P11S-4UX	-	100	60	232	-	-	-	-	-	100	100	253
	250	FRN250G11S-4UX	FRN250P11S-4UX	-	150	100	282	-	-	-	-	-	150	100	304
300	FRN300G11S-4UX	FRN300P11S-4UX	-	150	150	352	-	-	-	-	-	200	150	377	
350	FRN350G11S-4UX	FRN350P11S-4UX	-	200	150	385	-	-	-	-	-	200	150	415	
400	FRN400G11S-4UX	FRN400P11S-4UX	-	250	200	491	-	-	-	-	-	2x150	200	520	
450	FRN450G11S-4UX	FRN450P11S-4UX	-	2x150	250	552	-	-	-	-	-	2x150	250	585	
500	FRN500G11S-4UX	FRN500P11S-4UX	-	2x200	250	624	-	-	-	-	-	2x200	325	650	
600	FRN600G11S-4UX	FRN600P11S-4UX	-	2x200	325	704	-	-	-	-	-	2x250	325	740	
700	-	FRN700P11S-4UX	-	2x250	2x200	792	-	-	-	-	-	-	-	-	
800	FRN800G11S-4UX	FRN800P11S-4UX	-	2x325	2x200	880	-	-	-	-	-	-	-	-	

* Select an appropriate wire size referring to Table 3.1 and Table 3.2 if conditions such as ambient temperature or power voltage are different.
 NOTES: *1) Allowable temperature 60°C (140°F) means using "IV wire"; 75°C (167°F) means "600V HIV insulation wire"; and 90°C (194°F) means "600V cross-linking polyethylene insulation wire".

Table 3.3 (a) Wire size (50°C (122°F)) (cont'd)

Recommended wire size [mm ²]																								
Output circuit [U, V, W]				DC link circuit				Braking circuit [P(+), DB, N(-)]								Control circuit			Auxiliary control power supply [R0, T0]			Grounding		
P11S series				[P1, P(+)]				G11S series				P11S series										[⊕ G]		
Allowable temp.*1)			Current	Allowable temp.*1)			Current	Allowable temp.*1)			Current	Allowable temp.*1)			Current	Allowable temp.*1)			Allowable temp.*1)			Allowable temp.*1)		
60°C(140°F)	75°C(167°F)	90°C(194°F)	[A]	60°C(140°F)	75°C(167°F)	90°C(194°F)	[A]	60°C(140°F)	75°C(167°F)	90°C(194°F)	[A]	60°C(140°F)	75°C(167°F)	90°C(194°F)	[A]	60°C(140°F)	75°C(167°F)	90°C(194°F)	60°C(140°F)	75°C(167°F)	90°C(194°F)	60°C(140°F)	75°C(167°F)	90°C(194°F)
-	-	-	-	2.0	2.0	2.0	1.1	2.0	2.0	2.0	1.2	-	-	-	-	-	-	-	2.0	2.0	2.0	-	-	-
-	-	-	-	2.0	2.0	2.0	2.0	2.0	2.0	2.0	1.2	-	-	-	-	-	-	-	2.0	2.0	2.0	-	-	-
-	-	-	-	2.0	2.0	2.0	3.8	2.0	2.0	2.0	1.6	-	-	-	-	-	-	-	2.0	2.0	2.0	-	-	-
-	-	-	-	2.0	2.0	2.0	7.0	2.0	2.0	2.0	3.6	-	-	-	-	-	-	-	2.0	2.0	2.0	-	-	-
-	-	-	-	2.0	2.0	2.0	10	2.0	2.0	2.0	3.5	-	-	-	-	-	-	-	2.0	2.0	2.0	-	-	-
-	-	-	-	2.0	2.0	2.0	17	2.0	2.0	2.0	4.1	-	-	-	-	-	-	-	2.0	2.0	2.0	-	-	-
5.5	2.0	2.0	22	5.5	3.5	3.5	24	2.0	2.0	2.0	6.4	2.0	2.0	2.0	3.5	1.25	1.25	1.25	2.0	2.0	2.0	3.5	3.5	3.5
8.0	3.5	2.0	29	8.0	3.5	3.5	33	2.0	2.0	2.0	6.1	2.0	2.0	2.0	5.3	1.25	1.25	1.25	2.0	2.0	2.0	5.5	5.5	5.5
14	5.5	3.5	42	14	8.0	5.5	48	2.0	2.0	2.0	9.1	2.0	2.0	2.0	5.1	1.25	1.25	1.25	2.0	2.0	2.0	14	14	14
22	8.0	5.5	55	22	14	8.0	66	2.0	2.0	2.0	11	2.0	2.0	2.0	7.2	1.25	1.25	1.25	2.0	2.0	2.0	22	22	22
-	14	8.0	67	-	22	14	81	2.0	2.0	2.0	14	2.0	2.0	2.0	9.3	1.25	1.25	1.25	2.0	2.0	2.0	-	14	8.0
-	14	14	78	-	22	14	96	2.0	2.0	2.0	15	2.0	2.0	2.0	11	1.25	1.25	1.25	2.0	2.0	2.0	-	14	14
-	38	22	115	-	38	38	133	3.5	3.5	3.5	19	3.5	3.5	3.5	19	1.25	1.25	1.25	2.0	2.0	2.0	-	38	22
-	38	38	145	-	60	38	165	5.5	3.5	3.5	25	3.5	3.5	3.5	19	1.25	1.25	1.25	2.0	2.0	2.0	-	38	38
-	60	38	180	-	60	60	200	8.0	3.5	3.5	30	5.5	3.5	3.5	25	1.25	1.25	1.25	2.0	2.0	2.0	-	60	38
-	100	60	215	-	100	60	244	14	5.5	3.5	37	8.0	3.5	3.5	30	1.25	1.25	1.25	2.0	2.0	2.0	-	100	60
-	100	100	283	-	150	100	333	14	8.0	5.5	45	14	5.5	3.5	37	1.25	1.25	1.25	2.0	2.0	2.0	-	100	100
-	150	150	346	-	200	150	400	22	14	8.0	61	14	8.0	5.5	48	1.25	1.25	1.25	2.0	2.0	2.0	-	150	100
-	200	150	415	-	250	200	490	-	-	-	-	22	14	8.0	61	1.25	1.25	1.25	2.0	2.0	2.0	-	200	150
-	-	-	-	2.0	2.0	2.0	1.0	2.0	2.0	2.0	0.8	-	-	-	-	-	-	-	2.0	2.0	2.0	-	-	-
-	-	-	-	2.0	2.0	2.0	1.8	2.0	2.0	2.0	1.1	-	-	-	-	-	-	-	2.0	2.0	2.0	-	-	-
-	-	-	-	2.0	2.0	2.0	3.6	2.0	2.0	2.0	1.8	-	-	-	-	-	-	-	2.0	2.0	2.0	-	-	-
-	-	-	-	2.0	2.0	2.0	5.1	2.0	2.0	2.0	1.8	-	-	-	-	-	-	-	2.0	2.0	2.0	-	-	-
-	-	-	-	2.0	2.0	2.0	8.7	2.0	2.0	2.0	2.1	-	-	-	-	-	-	-	2.0	2.0	2.0	-	-	-
2.0	-	-	12.5	2.0	2.0	2.0	12	2.0	2.0	2.0	3.2	2.0	2.0	2.0	1.8	1.25	1.25	1.25	2.0	2.0	2.0	3.5	3.5	3.5
3.5	2.0	2.0	16.5	3.5	5.5	5.5	17	2.0	2.0	2.0	3.1	2.0	2.0	2.0	2.7	1.25	1.25	1.25	2.0	2.0	2.0	5.5	5.5	5.5
5.5	-	-	23	5.5	5.5	5.5	24	2.0	2.0	2.0	4.5	2.0	2.0	2.0	2.5	1.25	1.25	1.25	2.0	2.0	2.0	8.0	8.0	8.0
8.0	3.5	-	30	8.0	5.5	3.5	32	2.0	2.0	2.0	5.7	2.0	2.0	2.0	3.6	1.25	1.25	1.25	2.0	2.0	2.0	14	14	14
14	5.5	3.5	37	14	5.5	3.5	40	2.0	2.0	2.0	7.2	2.0	2.0	2.0	4.6	1.25	1.25	1.25	2.0	2.0	2.0	22	22	22
14	5.5	5.5	44	14	8.0	5.5	48	2.0	2.0	2.0	7.7	2.0	2.0	2.0	5.7	1.25	1.25	1.25	2.0	2.0	2.0	38	38	38
22	14	8.0	60	22	14	8.0	66	2.0	2.0	2.0	10	2.0	2.0	2.0	10	1.25	1.25	1.25	2.0	2.0	2.0	60	60	60
38	14	14	75	38	22	14	82	2.0	2.0	2.0	12	2.0	2.0	2.0	10	1.25	1.25	1.25	2.0	2.0	2.0	38	38	38
38	22	14	91	60	22	14	99	2.0	2.0	2.0	15	2.0	2.0	2.0	12	1.25	1.25	1.25	2.0	2.0	2.0	38	22	14
60	38	22	112	60	38	22	122	3.5	3.5	3.5	19	3.5	3.5	3.5	15	1.25	1.25	1.25	2.0	2.0	2.0	60	22	14
100	60	38	150	100	60	38	164	5.5	5.5	5.5	24	3.5	3.5	3.5	19	1.25	1.25	1.25	2.0	2.0	2.0	-	38	38
-	60	38	176	-	60	60	196	8.0	3.5	3.5	31	5.5	3.5	3.5	24	1.25	1.25	1.25	2.0	2.0	2.0	100	60	38
-	100	60	210	-	100	60	240	8.0	5.5	3.5	34	8.0	3.5	3.5	31	1.25	1.25	1.25	2.0	2.0	2.0	-	60	60
-	100	100	253	-	150	100	284	14	5.5	3.5	41	8.0	5.5	3.5	34	1.25	1.25	1.25	2.0	2.0	2.0	-	100	60
-	150	100	304	-	150	150	345	14	8.0	5.5	50	14	5.5	3.5	41	1.25	1.25	1.25	2.0	2.0	2.0	-	150	100
-	200	150	377	-	250	150	431	22	14	8.0	62	14	8.0	5.5	50	1.25	1.25	1.25	2.0	2.0	2.0	-	150	150
-	200	150	415	-	250	200	472	38	14	14	71	22	14	8.0	62	1.25	1.25	1.25	2.0	2.0	2.0	-	200	150
-	2x150	200	520	-	2x200	250	601	60	22	14	100	38	14	14	71	1.25	1.25	1.25	2.0	2.0	2.0	-	250	200
-	2x150	250	585	-	2x200	2x150	676	60	22	14	100	60	22	14	100	1.25	1.25	1.25	2.0	2.0	2.0	-	325	250
-	2x200	2x150	650	-	2x250	2x200	764	60	38	22	124	60	22	14	100	1.25	1.25	1.25	2.0	2.0	2.0	-	400	250
-	2x250	325	740	-	2x325	2x200	862	60	38	22	124	60	38	22	124	1.25	1.25	1.25	2.0	2.0	2.0	-	500	325
-	2x250	2x200	840	-	2x325	2x250	970	-	-	-	60	38	22	124	1.25	1.25	1.25	2.0	2.0	2.0	-	-	400	
-	2x325	2x250	960	-	2x325	2x325	1078	-	-	-	60	38	22	124	1.25	1.25	1.25	2.0	2.0	2.0	-	-	500	

Chapter 3
3. Wire Size

(b) Under the 40°C (104°F) or lower panel inside temperature

Table 3.3 (b) Wire size (40°C (104°F))

Power supply voltage	Nominal applied motor [HP]	Inverter type		Recommended wire size [mm ²]											
				Input circuit [L1/R, L2/S, L3/T]						Output circuit [U, V, W]					
		G11S series	P11S series	With DCR			Without reactor			G11S series					
				Allowable temp.*1)			Current	Allowable temp.*1)			Current	Allowable temp.*1)			
60°C (140°F)	75°C (167°F)	90°C (194°F)	[A]	60°C (140°F)	75°C (167°F)	90°C (194°F)	[A]	60°C (140°F)	75°C (167°F)	90°C (194°F)	[A]				
Three-phase 230V	1/4	FRNF25G11S-2UX	-	2.0	2.0	2.0	0.9	2.0	2.0	2.0	1.8	2.0	2.0	2.0	1.5
	1/2	FRNF50G11S-2UX					1.6				3.4				3
	1	FRN001G11S-2UX					3.1				6.4				5
	2	FRN002G11S-2UX					5.7				11.1				8
	3	FRN003G11S-2UX					8.3				16.1				11
	5	FRN005G11S-2UX					14				25.5				17
	7.5	FRN007G11S-2UX	FRN007P11S-2UX	19.7	8	5.5	3.5	40.8	3.5	25					
	10	FRN010G11S-2UX	FRN010P11S-2UX	26.9	14	8	5.5	52.6	5.5	35	33				
	15	FRN015G11S-2UX	FRN015P11S-2UX	5.5	5.5	3.5	39	22	14	8	76.9	8	5.5	3.5	46
	20	FRN020G11S-2UX	FRN020P11S-2UX	14	8	5.5	54	-	22	14	98.5	14	8	5.5	59
	25	FRN025G11S-2UX	FRN025P11S-2UX	14	14	8	66.2	-	22	22	117	22	14	8	74
	30	FRN030G11S-2UX	FRN030P11S-2UX	22	14	14	78.8	-	38	22	136	22	14	14	87
	40	FRN040G11S-2UX	FRN040P11S-2UX	38	22	14	109	60	38	38	168	-	22	22	115
	50	-	FRN050P11S-2UX	60	38	22	135	-	60	38	204	60	38	22	145
		FRN050G11S-2UX	-												
60	FRN060G11S-2UX	FRN060P11S-2UX	60	38	38	163	100	100	60	243	100	60	38	180	
75	FRN075G11S-2UX	FRN075P11S-2UX	100	60	38	199	-	100	100	291	100	60	60	215	
100	-	FRN100P11S-2UX	-	100	60	272	-	-	-	-	150	100	100	283	
	FRN100G11S-2UX	-	150												
125	FRN125G11S-2UX	FRN125P11S-2UX	200	150	100	327	-	-	-	-	200	150	100	346	
150	-	FRN150P11S-2UX	250	150	150	400	-	-	-	-	-	-	-	-	
Three-phase 460V	1/2	FRNF50G11S-4UX	-	2.0	2.0	2.0	0.82	2.0	2.0	2.0	1.8	2.0	2.0	2.0	1.5
	1	FRN001G11S-4UX					1.5				3.5				2.5
	2	FRN002G11S-4UX					2.9				6.2				3.7
	3	FRN003G11S-4UX					4.2				9.2				5.5
	5	FRN005G11S-4UX					7.1				14.9				9
	7.5	FRN007G11S-4UX					FRN007P11S-4UX				10				21.5
	10	FRN010G11S-4UX	FRN010P11S-4UX	13.5	3.5	27.9	18								
	15	FRN015G11S-4UX	FRN015P11S-4UX	19.8	5.5	5.5	3.5	39.1	3.5	24					
	20	FRN020G11S-4UX	FRN020P11S-4UX	3.5	26.8	14	5.5	5.5	50.3	3.5	3.5	30			
	25	FRN025G11S-4UX	FRN025P11S-4UX	5.5	3.5	33.2	14	8	5.5	59.9	5.5	3.5	3.5	39	
	30	FRN030G11S-4UX	FRN030P11S-4UX	5.5	5.5	3.5	39.3	14	8	69.3	8	5.5	3.5	45	
	40	FRN040G11S-4UX	FRN040P11S-4UX	14	8	5.5	54	22	14	14	86	14	8	5.5	60
	50	FRN050G11S-4UX	FRN050P11S-4UX	14	14	8	67	38	22	14	104	22	14	8	75
	60	FRN060G11S-4UX	FRN060P11S-4UX	22	14	14	81	38	22	22	124	22	14	14	91
	75	FRN075G11S-4UX	FRN075P11S-4UX	38	22	14	100	60	38	38	150	38	22	14	112
	100	-	FRN100P11S-4UX	60	38	22	134	-	-	-	-	60	38	38	150
		FRN100G11S-4UX	-												
	125	FRN125G11S-4UX	FRN125P11S-4UX	60	38	38	160	-	-	-	-	60	60	38	176
	150	FRN150G11S-4UX	FRN150P11S-4UX	100	60	38	196	-	-	-	-	100	60	60	210
	200	FRN200G11S-4UX	FRN200P11S-4UX	100	60	60	232	-	-	-	-	150	100	60	253
250	FRN250G11S-4UX	FRN250P11S-4UX	150	100	100	282	-	-	-	-	150	100	100	304	
300	FRN300G11S-4UX	FRN300P11S-4UX	200	150	100	352	-	-	-	-	200	150	100	377	
350	FRN350G11S-4UX	FRN350P11S-4UX	250	150	150	385	-	-	-	-	250	150	150	415	
400	FRN400G11S-4UX	FRN400P11S-4UX	-	200	150	491	-	-	-	-	-	250	200	520	
450	FRN450G11S-4UX	FRN450P11S-4UX	-	250	200	552	-	-	-	-	-	250	200	585	
500	FRN500G11S-4UX	FRN500P11S-4UX	-	2x150	250	624	-	-	-	-	-	325	250	650	
600	FRN600G11S-4UX	FRN600P11S-4UX	-	2x150	250	704	-	-	-	-	-	2x200	325	740	
700	-	FRN700P11S-4UX	-	2x200	2x150	792	-	-	-	-	-	-	-	-	
800	-	FRN800P11S-4UX	-	2x250	2x200	880	-	-	-	-	-	-	-	-	

* Select an appropriate wire size referring to Table 3.1 and Table 3.2 if conditions such as ambient temperature or power voltage are different.
 NOTES: *1) Allowable temperature 60°C (140°F) means using "IV wire"; 75°C (167°F) means "600V HIV insulation wire"; and 90°C (194°F) means "600V cross-linking polyethylene insulation wire".

Table 3.3 (b) Wire size (40°C (104°F)) (cont'd)

Recommended wire size [mm ²]																																																										
Output circuit [U, V, W]				DC link circuit				Braking circuit [P(+), DB, N(-)]								Control circuit			Auxiliary control power supply [R0, T0]			Grounding																																				
P11S series				[P1, P(+)]				G11S series				P11S series										[⊕ G]																																				
Allowable temp.*1)			Current	Allowable temp.*1)			Current	Allowable temp.*1)			Current	Allowable temp.*1)			Current	Allowable temp.*1)			Allowable temp.*1)			Allowable temp.*1)																																				
60°C(140°F)	75°C(167°F)	90°C(194°F)	[A]	60°C(140°F)	75°C(167°F)	90°C(194°F)	[A]	60°C(140°F)	75°C(167°F)	90°C(194°F)	[A]	60°C(140°F)	75°C(167°F)	90°C(194°F)	[A]	60°C(140°F)	75°C(167°F)	90°C(194°F)	60°C(140°F)	75°C(167°F)	90°C(194°F)	60°C(140°F)	75°C(167°F)	90°C(194°F)																																		
-	-	-	-	2.0	2.0	2.0	1.1	2.0	2.0	2.0	2.0	2.0	2.0	2.0	2.0	2.0	2.0	2.0	2.0	2.0	2.0	2.0	2.0	2.0																																		
-	-	-	-	2.0	2.0	2.0	2.0																		2.0	2.0	2.0	2.0	2.0	2.0	2.0	2.0	2.0	2.0	2.0	2.0	2.0	2.0	2.0	2.0	2.0																	
2.0	2.0	2.0	22	3.5	3.5	3.5	2.0																		2.0	2.0	2.0	2.0	2.0	2.0	2.0	2.0	2.0	2.0	2.0	2.0	2.0	2.0	2.0	2.0	2.0																	
3.5	2.0	2.0	29	5.5	3.5	3.5	3.5																		3.5	3.5	3.5	3.5	3.5	3.5	3.5	3.5	3.5	3.5	3.5	3.5	3.5	3.5	3.5	3.5	3.5																	
8.0	5.5	3.5	42	8.0	5.5	5.5	48																		48	48	48	48	48	48	48	48	48	48	48	48	48	48	48	48	48																	
14	8.0	5.5	55	14	14	8.0	66																		66	66	66	66	66	66	66	66	66	66	66	66	66	66	66	66	66																	
14	14	8.0	67	22	14	14	81																		81	81	81	81	81	81	81	81	81	81	81	81	81	81	81	81	81																	
22	14	8.0	78	-	22	14	96																		96	96	96	96	96	96	96	96	96	96	96	96	96	96	96	96	96																	
38	22	22	115	60	38	22	133																		133	133	133	133	133	133	133	133	133	133	133	133	133	133	133	133	133																	
60	38	22	145	60	38	38	165																		3.5	3.5	3.5	3.5	3.5	3.5	3.5	3.5	3.5	3.5	3.5	3.5	3.5	3.5	3.5	3.5	3.5																	
100	60	38	180	100	60	38	200																		3.5	3.5	3.5	3.5	3.5	3.5	3.5	3.5	3.5	3.5	3.5	3.5	3.5	3.5	3.5	3.5	3.5																	
100	60	60	215	100	100	60	244																		5.5	3.5	3.5	3.5	37	3.5	3.5	3.5	3.5	3.5	3.5	3.5	3.5	3.5	3.5	3.5	3.5																	
-	100	100	283	-	150	100	333																		8.0	5.5	5.5	48	5.5	3.5	3.5	3.5	3.5	3.5	3.5	3.5	3.5	3.5	3.5	3.5	3.5																	
-	150	100	346	-	150	150	400																		14	8.0	5.5	61	8.0	5.5	5.5	48	48	48	48	48	48	48	48	48	48																	
-	150	150	415	-	200	150	490																		-	-	-	-	14	8.0	5.5	61	61	61	61	61	61	61	61	61	61																	
-	-	-	-	2.0	2.0	2.0	1.0																		2.0	2.0	2.0	2.0	2.0	2.0	2.0	2.0	2.0	2.0	2.0	2.0	2.0	2.0	2.0	2.0	2.0																	
-	-	-	-	2.0	2.0	2.0	1.8																																			2.0	2.0	2.0	2.0	2.0	2.0	2.0	2.0	2.0	2.0	2.0	2.0	2.0	2.0	2.0	2.0	2.0
2.0	2.0	2.0	12.5	3.5	3.5	3.5	12																																			2.0	2.0	2.0	2.0	2.0	2.0	2.0	2.0	2.0	2.0	2.0	2.0	2.0	2.0	2.0	2.0	2.0
3.5	3.5	3.5	16.5	5.5	5.5	5.5	17																																			2.0	2.0	2.0	2.0	2.0	2.0	2.0	2.0	2.0	2.0	2.0	2.0	2.0	2.0	2.0	2.0	2.0
3.5	3.5	3.5	23	5.5	5.5	5.5	24																																			2.0	2.0	2.0	2.0	2.0	2.0	2.0	2.0	2.0	2.0	2.0	2.0	2.0	2.0	2.0	2.0	2.0
3.5	3.5	3.5	30	5.5	5.5	5.5	32	2.0	2.0	2.0	2.0	2.0	2.0	2.0	2.0	2.0	2.0	2.0	2.0	2.0	2.0	2.0	2.0	2.0																																		
5.5	3.5	3.5	37	5.5	5.5	5.5	40	2.0	2.0	2.0	2.0	2.0	2.0	2.0	2.0	2.0	2.0	2.0	2.0	2.0	2.0	2.0	2.0	2.0																																		
8.0	5.5	3.5	44	8.0	5.5	5.5	48	2.0	2.0	2.0	2.0	2.0	2.0	2.0	2.0	2.0	2.0	2.0	2.0	2.0	2.0	2.0	2.0	2.0																																		
14	8.0	5.5	60	14	14	8.0	66	2.0	2.0	2.0	2.0	2.0	2.0	2.0	2.0	2.0	2.0	2.0	2.0	2.0	2.0	2.0	2.0	2.0																																		
22	14	8.0	75	22	14	14	82	2.0	2.0	2.0	2.0	2.0	2.0	2.0	2.0	2.0	2.0	2.0	2.0	2.0	2.0	2.0	2.0	2.0																																		
22	14	14	91	38	22	14	99	2.0	2.0	2.0	2.0	2.0	2.0	2.0	2.0	2.0	2.0	2.0	2.0	2.0	2.0	2.0	2.0	2.0																																		
38	22	14	112	38	22	22	122	2.0	2.0	2.0	2.0	2.0	2.0	2.0	2.0	2.0	2.0	2.0	2.0	2.0	2.0	2.0	2.0	2.0																																		
60	38	38	150	60	38	38	164	3.5	3.5	3.5	3.5	3.5	3.5	3.5	3.5	3.5	3.5	3.5	3.5	3.5	3.5	3.5	3.5	3.5																																		
60	60	38	176	100	60	38	196	5.5	3.5	3.5	3.5	31	3.5	3.5	3.5	3.5	3.5	3.5	3.5	3.5	3.5	3.5	3.5	3.5																																		
100	60	60	210	100	100	60	240	5.5	3.5	3.5	3.5	34	5.5	3.5	3.5	3.5	3.5	3.5	3.5	3.5	3.5	3.5	3.5	3.5																																		
150	100	60	253	150	100	100	284	8.0	5.5	3.5	3.5	41	5.5	3.5	3.5	3.5	3.5	3.5	3.5	3.5	3.5	3.5	3.5	3.5																																		
150	100	100	304	200	150	100	345	8.0	5.5	5.5	5.5	50	8.0	5.5	5.5	5.5	5.5	5.5	5.5	5.5	5.5	5.5	5.5	5.5																																		
200	150	100	377	250	200	150	431	14	8.0	5.5	62	8.0	5.5	5.5	5.5	5.5	5.5	5.5	5.5	5.5	5.5	5.5	5.5	5.5																																		
250	150	150	415	325	200	150	472	14	14	8.0	71	14	8.0	5.5	62	62	62	62	62	62	62	62	62	62																																		
325	250	200	520	-	2x150	200	601	38	22	14	100	14	14	8.0	71	71	71	71	71	71	71	71	71	71																																		
-	250	200	585	-	2x150	250	676	38	22	14	100	38	22	14	100	100	100	100	100	100	100	100	100	100																																		
-	2x150	250	650	-	2x200	2x150	764	38	22	22	124	38	22	22	124	124	124	124	124	124	124	124	124	124																																		
-	2x200	325	740	-	2x200	2x200	862	38	22	22	124	38	22	22	124	124	124	124	124	124	124	124	124	124																																		
-	2x200	2x150	840	-	2x250	2x200	970	-	-	-	-	38	22	22	124	124	124	124	124	124	124	124	124	124																																		
-	2x250	2x200	960	-	2x325	2x250	1078	-	-	-	-	38	22	22	124	124	124	124	124	124	124	124	124	124																																		

3

Chapter 3

3. Wire Size

3.2 Allowable current of insulation wire

■ IV wire (Maximum allowable temperature : 60°C (140°F))

Table 3.5 (a) Allowable current of insulation wire

Wire size [mm ²]	Allowable current reference value (up to 30°C (86°F)) I_0 [A]	Wiring outside duct					Wiring in the duct (Max. 3 wires in one duct)				
		35°C (95°F) ($I_0 \times 0.91$) [A]	40°C (104°F) ($I_0 \times 0.82$) [A]	45°C (113°F) ($I_0 \times 0.71$) [A]	50°C (122°F) ($I_0 \times 0.58$) [A]	55°C (131°F) ($I_0 \times 0.41$) [A]	35°C (95°F) ($I_0 \times 0.63$) [A]	40°C (104°F) ($I_0 \times 0.57$) [A]	45°C (113°F) ($I_0 \times 0.49$) [A]	50°C (122°F) ($I_0 \times 0.40$) [A]	
2	27	24	22	19	15	11	17	15	13	10	
3.5	37	33	30	26	21	15	23	21	18	14	
5.5	49	44	40	34	28	20	30	27	24	19	
8	61	55	50	43	35	25	38	34	29	24	
14	88	80	72	62	51	36	55	50	43	35	
22	115	104	94	81	66	47	72	65	56	46	
38	162	147	132	115	93	66	102	92	79	64	
60	217	197	177	154	125	88	136	123	106	86	
100	298	271	244	211	172	122	187	169	146	119	
150	395	359	323	280	229	161	248	225	193	158	
200	469	426	384	332	272	192	295	267	229	187	
250	556	505	455	394	322	227	350	316	272	222	
325	650	591	533	461	377	266	409	370	318	260	
400	745	677	610	528	432	305	469	424	365	298	
500	842	766	690	597	488	345	530	479	412	336	
2 x 100	497	452	407	352	288	203	313	283	243	198	
2 x 150	658	598	539	467	381	269	414	375	322	263	
2 x 200	782	711	641	555	453	320	492	445	383	312	
2 x 250	927	843	760	658	537	380	584	528	454	370	
2 x 325	1083	985	888	768	628	444	682	617	530	433	
2 x 400	1242	1130	1018	881	720	509	782	707	608	496	
2 x 500	1403	1276	1150	996	813	575	883	799	687	561	

■ HIV wire (Maximum allowable temperature : 75°C (167°F))

Table 3.5 (b) Allowable current of insulation wire

Wire size [mm ²]	Allowable current reference value (up to 30°C (86°F)) $I_0 \times 1.22$ [A]	Wiring outside duct					Wiring in the duct (Max. 3 wires in one duct)				
		35°C (95°F) ($I_0 \times 1.15$) [A]	40°C (104°F) ($I_0 \times 1.08$) [A]	45°C (113°F) ($I_0 \times 1.00$) [A]	50°C (122°F) ($I_0 \times 0.91$) [A]	55°C (131°F) ($I_0 \times 0.82$) [A]	35°C (95°F) ($I_0 \times 0.80$) [A]	40°C (104°F) ($I_0 \times 0.75$) [A]	45°C (113°F) ($I_0 \times 0.70$) [A]	50°C (122°F) ($I_0 \times 0.63$) [A]	
2	32	31	29	27	24	22	21	20	18	17	
3.5	45	42	39	37	33	30	29	27	25	23	
5.5	59	56	52	49	44	40	39	36	34	30	
8	74	70	65	61	55	50	48	45	42	38	
14	107	101	95	88	80	72	70	66	61	55	
22	140	132	124	115	104	94	92	86	80	72	
38	197	186	174	162	147	132	129	121	113	102	
60	264	249	234	217	197	177	173	162	151	136	
100	363	342	321	298	271	244	238	223	208	187	
150	481	454	426	395	359	323	316	296	276	248	
200	572	539	506	469	426	384	375	351	328	295	
250	678	639	600	556	505	455	444	417	389	350	
325	793	747	702	650	591	533	520	487	455	409	
400	908	856	804	745	677	610	596	558	521	469	
500	1027	968	909	842	766	690	673	631	589	530	
2 x 100	606	571	536	497	452	407	397	372	347	313	
2 x 150	802	756	710	658	598	539	526	493	460	414	
2 x 200	954	899	844	782	711	641	625	586	547	492	
2 x 250	1130	1066	1001	927	843	760	741	695	648	584	
2 x 325	1321	1245	1169	1083	985	888	866	812	758	682	
2 x 400	1515	1428	1341	1242	1130	1018	993	931	869	782	
2 x 500	1711	1613	1515	1403	1276	1150	1122	1052	982	883	

■ 600V cross-linking polyethylene insulation wire (Maximum allowable temperature: 90°C (194°F))

Table 3.5 (c) Allowable current of insulation wire

Wire size [mm ²]	Allowable current reference value (up to 30°C (86°F)) $I_0 \times 1.41$ [A]	Wiring outside duct					Wiring in the duct (Max. 3 wires in one duct)			
		35°C (95°F) ($I_0 \times 1.35$) [A]	40°C (104°F) ($I_0 \times 1.29$) [A]	45°C (113°F) ($I_0 \times 1.22$) [A]	50°C (122°F) ($I_0 \times 1.15$) [A]	55°C (131°F) ($I_0 \times 1.08$) [A]	35°C (95°F) ($I_0 \times 0.94$) [A]	40°C (104°F) ($I_0 \times 0.90$) [A]	45°C (113°F) ($I_0 \times 0.85$) [A]	50°C (122°F) ($I_0 \times 0.80$) [A]
2	38	36	34	32	31	29	25	24	22	21
3.5	52	49	47	45	42	39	34	33	31	29
5.5	69	66	63	59	56	52	46	44	41	39
8	86	82	78	74	70	65	57	54	51	48
14	124	118	113	107	101	95	82	79	74	70
22	162	155	148	140	132	124	108	103	97	92
38	228	218	208	197	186	174	152	145	137	129
60	305	292	279	264	249	234	203	195	184	173
100	420	402	384	363	342	321	280	268	253	238
150	556	533	509	481	454	426	371	355	335	316
200	661	633	605	572	539	506	440	422	398	375
250	783	750	717	678	639	600	522	500	472	444
325	916	877	838	793	747	702	611	585	552	520
400	1050	1005	961	908	856	804	700	670	633	596
500	1187	1136	1086	1027	968	909	791	757	715	673
2 x 100	700	670	641	606	571	536	467	447	422	397
2 x 150	927	888	848	802	756	710	618	592	559	526
2 x 200	1102	1055	1008	954	899	844	735	703	664	625
2 x 250	1307	1251	1195	1130	1066	1001	871	834	787	741
2 x 325	1527	1462	1397	1321	1245	1169	1018	974	920	866
2 x 400	1751	1676	1602	1515	1428	1341	1167	1117	1055	993
2 x 500	1978	1894	1809	1711	1613	1515	1318	1262	1192	1122

Chapter 3

4. Braking Unit and Braking Resistor

4. Braking Unit and Braking Resistor

■ 230V

Table 3.6 Braking unit and braking resistor (G11S-2 series)

Power supply voltage	Inverter type	Option					Maximum braking torque [%]		Cont. braking (100% torque conversion value)		Repetitive braking (100s or less cycle)				
		Braking unit		Braking resistor			50Hz [lb-in (N·m)]	60Hz [lb-in (N·m)]	Dis-charging capability [kW]	Braking time [s]	Average loss [kW]	Duty cycle [%]			
		Type	Q'ty	Type	Q'ty	Total ohmic value [Ω]	[N·m]	[N·m]							
Three-phase 230V	FRNF25G11S-2UX	-	-	DB0.75-2	1	100	150	17.6(1.99)	14.6(1.65)	9	90	0.037	37		
	FRNF50G11S-2UX							35.6(4.02)	29.4(3.32)	9	45	0.044	22		
	FRN001G11S-2UX							67(7.57)	55.3(6.25)	17	45	0.068	18		
	FRN002G11S-2UX			DB2.2-2	1	40		133(15.0)	110(12.4)	34	45	0.075	10		
	FRN003G11S-2UX							195(22.0)	161(18.2)	33	30	0.077	7		
	FRN005G11S-2UX							328(37.1)	270(30.5)	37	20	0.093	5		
	FRN007G11S-2UX			DB5.5-2	1	20		481(54.3)	398(45.0)	55	20	0.138	5		
	FRN010G11S-2UX			DB7.5-2	1	15		651(73.6)	545(61.6)	37	10	0.188	5		
	FRN015G11S-2UX			BU3-185-2	1	DB11-2		1	10	956(108)	792(89.5)	55	10	0.275	5
	FRN020G11S-2UX									1301(147)	1080(122)	75	10	0.375	5
	FRN025G11S-2UX	1611(182)	1336(151)							92	10	0.463	5		
	FRN030G11S-2UX	BU3-220-2	1	DB22-2	1	5.8		1912(216)	1584(179)	88	8	0.550	5		
	FRN040G11S-2UX	BU37-2C	1	DB30-2C	1	4.0		1726(195)	1434(162)	150	10	1.50	10		
	FRN050G11S-2UX							2124(240)	1770(200)	185	10	1.85	10		
	FRN060G11S-2UX	BU55-2C	1	DB45-2C	1	2.5		2584(292)	2151(243)	225	10	2.25	10		
	FRN075G11S-2UX							3177(359)	2638(298)	275	10	2.75	10		
	FRN100G11S-2UX	BU90-2C	1	DB75-2C	1	1.5		4310(487)	3585(405)	375	10	3.75	10		
FRN125G11S-2UX	5178(585)						4301(486)	450	10	4.50	10				

NOTE: • Refer to Selection procedure and Notes on Selection.
• Maximum braking torque is based on the rated torque run by a commercial power supply.

Table 3.7 Braking unit and braking resistor (P11S-2 series)

Power supply voltage	Inverter type	Option					Maximum braking torque [%]		Cont. braking (100% torque conversion value)		Repetitive braking (100s or less cycle)		
		Braking unit		Braking resistor			50Hz [lb-in (N·m)]	60Hz [lb-in (N·m)]	Dis-charging capability [kW]	Braking time [s]	Average loss [kW]	Duty cycle [%]	
		Type	Q'ty	Type	Q'ty	Total ohmic value [Ω]	[N·m]	[N·m]					
Three-phase 230V	FRN007P11S-2UX	-	-	DB3.7-2	1	33	100	320(36.2)	266(30.0)	37	15	0.093	3.5
	FRN010P11S-2UX			DB5.5-2	1	20		435(49.1)	363(41.0)	55	15	0.138	3.5
	FRN015P11S-2UX			DB7.5-2	1	15		637(72.0)	528(59.7)	37	7	0.188	3.5
	FRN020P11S-2UX	BU3-185-2	1	DB11-2	1	10		868(98.1)	720(81.4)	55	7	0.275	3.5
	FRN025P11S-2UX							1071(121)	885(100)	75	8	0.375	4
	FRN030P11S-2UX							1275(144)	1053(119)	92	8	0.463	4
	FRN040P11S-2UX	BU37-2C	1	DB30-2C	1	4.0		1292(146)	1434(162)	88	6	0.55	3.5
	FRN050P11S-2UX							1593(180)	1328(150)	150	8	1.50	8
	FRN060P11S-2UX	BU55-2C	1	DB37-2C	1	3.0		1938(219)	1611(182)	185	8	1.85	8
	FRN075P11S-2UX							2381(269)	1974(223)	225	8	2.25	8
	FRN100P11S-2UX	BU90-2C	1	DB55-2C	1	2.0		3231(365)	2682(303)	275	7	2.75	7
	FRN125P11S-2UX							3877(438)	3222(364)	375	8	3.75	8
	FRN150P11S-2UX	4726(534)	3930(444)	450	8	4.50		8					

NOTE: • Refer to Selection procedure and Notes on Selection.
• Maximum braking torque is based on the rated torque run by a commercial power supply.

4. Braking Unit and Braking Resistor

■ 460V

Table 3.8 Braking unit and braking resistor (G11S-4 series)

Power supply voltage	Inverter type	Option					Maximum braking torque [%]		Cont. braking (100% torque conversion value)		Repetitive braking (100s or less cycle)					
		Braking unit		Braking resistor			50Hz [lb-in (N·m)]	60Hz [lb-in (N·m)]	Discharging capability [kW]	Braking time [s]	Average loss [kW]	Duty cycle (%)				
		Type	Q'ty	Type	Q'ty	Total ohmic value [Ω]	[N·m]	[N·m]								
Three-phase 460V	FRNF50G11S-4UX	-	-	DB0.75-4	1	200	150	35.6(4.02)	29.4(3.32)	9	45	0.044	22			
	FRN001G11S-4UX			DB2.2-4	1	160		67.0(7.57)	55.3(6.25)	17	45	0.068	18			
	FRN002G11S-4UX				DB3.7-4	1		130	133(15.0)	110(12.4)	34	45	0.075	10		
	FRN003G11S-4UX					DB5.5-4		1	80	195(22.0)	161(18.2)	33	30	0.077	7	
	FRN005G11S-4UX							DB7.5-4	1	60	328(37.1)	270(30.5)	37	20	0.093	5
	FRN007G11S-4UX								DB11-4	1	40	482(54.5)	399(45.1)	55	20	0.138
	FRN010G11S-4UX	DB15-4	1							34.4	658(74.3)	545(61.6)	38	10	0.188	5
	FRN015G11S-4UX		DB18.5-4	1						27	956(108)	792(89.5)	55	10	0.275	5
	FRN020G11S-4UX			DB22-4	1					22	1301(147)	1080(122)	75	10	0.375	5
	FRN025G11S-4UX				DB30-4C	1				15	1611(182)	1336(151)	93	10	0.463	5
	FRN030G11S-4UX					DB37-4C		1		12	1912(216)	1584(179)	88	8	0.550	5
	FRN040G11S-4UX							DB45-4C	1	10	1726(195)	1434(162)	150	10	1.50	10
	FRN050G11S-4UX	DB55-4C							1	7.5	2124(240)	1770(200)	185	10	1.85	10
	FRN060G11S-4UX		DB75-4C						1	6.5	2584(292)	2151(243)	225	10	2.25	10
	FRN075G11S-4UX			DB110-4C					1	4.7	3177(359)	2638(298)	275	10	2.75	10
	FRN100G11S-4UX				DB132-4C				1	3.9	4310(487)	3585(405)	375	10	3.75	10
	FRN125G11S-4UX					DB160-4C			1	3.2	5178(585)	4301(486)	450	10	4.5	10
	FRN150G11S-4UX							DB200-4C	1	2.6	6302(712)	5240(592)	550	10	5.5	10
	FRN200G11S-4UX	DB220-4C							1	2.2	7567(855)	6284(710)	665	10	6.65	10
	FRN250G11S-4UX		DB200-4C						1	2.6	9169(1036)	7620(861)	800	10	8.0	10
FRN300G11S-4UX	DB220-4C			1			2.2		11462(1295)	9523(1076)	1000	10	10.0	10		
FRN350G11S-4UX				DB160-4C	2		1.6		12603(1424)	10479(1184)	1100	10	11.0	10		
FRN400G11S-4UX					DB160-4C	2	1.6		16046(1813)	13329(1506)	1600	11	16.0	11		
FRN450G11S-4UX						DB200-4C	2	1.3	18047(2039)	15002(1695)	1600	10	16.0	10		
FRN500G11S-4UX		DB200-4C					2	1.3	20339(2298)	16905(1910)	2000	11	20.0	11		
FRN600G11S-4UX			DB200-4C				2	1.3	22923(2590)	19047(2152)	2000	10	20.0	10		

NOTE: • Refer to Selection procedure and Notes on Selection.
 • Maximum braking torque is based on the rated torque run by a commercial power supply.

Table 3.9 Braking unit and braking resistor (P11S-4 series)

Power supply voltage	Inverter type	Option					Maximum braking torque [%]		Cont. braking (100% torque conversion value)		Repetitive braking (100s or less cycle)					
		Braking unit		Braking resistor			50Hz [lb-in (N·m)]	60Hz [lb-in (N·m)]	Discharging capability [kW]	Braking time [s]	Average loss [kW]	Duty cycle (%)				
		Type	Q'ty	Type	Q'ty	Total ohmic value [Ω]	[N·m]	[N·m]								
Three-phase 460V	FRN007P11S-4UX	-	-	DB3.7-4	1	130	100	321(36.3)	266(30.1)	37	15	0.093	3.5			
	FRN010P11S-4UX			DB5.5-4	1	80		439(49.6)	363(41.0)	55	15	0.138	3.5			
	FRN015P11S-4UX				DB7.5-4	1		60	636(71.9)	528(59.7)	38	7	0.188	3.5		
	FRN020P11S-4UX					DB11-4		1	40	868(98.1)	720(81.4)	55	7	0.275	3.5	
	FRN025P11S-4UX							DB15-4	1	34.4	1071(121)	885(100)	75	8	0.375	4
	FRN030P11S-4UX								DB18.5-4	1	27	1275(144)	1053(119)	93	8	0.463
	FRN040P11S-4UX	DB30-4C	1							15	1593(180)	1328(150)	88	6	0.55	3
	FRN050P11S-4UX		DB37-4C	1						12	1938(219)	1611(182)	185	8	1.85	8
	FRN060P11S-4UX			DB45-4C	1					10	2381(269)	1974(223)	225	8	2.25	8
	FRN075P11S-4UX				DB55-4C	1				7.5	3231(365)	2682(303)	275	7	2.75	7
	FRN100P11S-4UX					DB75-4C		1		6.5	3877(438)	3222(364)	375	8	3.75	8
	FRN125P11S-4UX							DB110-4C	1	4.7	4726(534)	3930(444)	450	8	4.5	8
	FRN150P11S-1UX	DB132-4C							1	4.7	5673(641)	4717(533)	550	8	5.5	8
	FRN200P11S-4UX		DB160-4C						1	3.9	6877(777)	5718(646)	665	8	6.65	8
	FRN250P11S-4UX			DB200-4C					1	3.2	8594(971)	7143(807)	800	8	8.0	8
	FRN300P11S-4UX				DB220-4C				1	2.6	9453(1068)	7859(888)	1000	9	10.0	9
	FRN350P11S-4UX					DB220-4C			1	2.2	12037(1360)	10001(1130)	1100	8	11.0	8
	FRN400P11S-4UX							DB160-4C	2	1.6	13542(1530)	11249(1271)	1600	10	16.0	10
	FRN450P11S-4UX	DB160-4C							2	1.6	15259(1724)	12674(1432)	1600	9	16.0	9
	FRN500P11S-4UX		DB200-4C						2	1.3	17188(1942)	14285(1614)	2000	10	20.0	10
FRN700P11S-4UX	DB200-4C			2			1.3		19339(2185)	16073(1816)	2000	9	20.0	9		
FRN800P11S-4UX				DB200-4C	2		1.3		21489(2428)	17852(2017)	2000	8	20.0	8		

NOTE: • Refer to Selection procedure and Notes on Selection.
 • Maximum braking torque is based on the rated torque run by a commercial power supply.

Chapter 3

5. Braking Unit and Braking Resistor (10% ED)

5. Braking Unit and Braking Resistor (10% ED)

[230V]

■FRN □□□ G11S-2 series, FRN □□□ P11S-2 series

Table 3.11 Braking unit and braking resistor (G11S 200V)

Power supply voltage	Inverter type	Option					Maximum braking torque [%]		Cont. braking (100% torque conversion value)		Repetitive braking (100s or less cycle)	
		Braking unit		Braking resistor			50Hz [lb-in (N·m)]	60Hz [lb-in (N·m)]	Discharging capability [kW]	Braking time [s]	Average loss [kW]	Duty cycle (%)
		Type	Q'ty	Type	Q'ty	Total ohmic value [Ω]	[N·m]	[N·m]				
Three-phase 230V	FRNF25G11S-2UX	-	-	DB0.75-2C	1	100	17.6(1.99)	14.6(1.65)	9	90	0.01	10
	FRNF50G11S-2UX						35.6(4.02)	29.4(3.32)	9	45	0.02	10
	FRN001G11S-2UX						67.0(7.57)	55.3(6.25)	17	45	0.0375	10
	FRN002G11S-2UX						133(15.0)	110(12.4)	34	45	0.075	10
	FRN003G11S-2UX						195(22.0)	161(18.2)	33	30	0.11	10
	FRN005G11S-2UX						328(37.1)	270(30.5)	37	20	0.185	10
	FRN007G11S-2UX			481(54.3)	398(45.0)	55	20	0.275	10			
	FRN010G11S-2UX			659(74.4)	545(61.6)	37	10	0.375	10			
	FRN015G11S-2UX			956(108)	792(89.5)	55	10	0.55	10			
	FRN020G11S-2UX			1301(147)	1080(122)	75	10	0.75	10			
	FRN025G11S-2UX			1611(182)	1337(151)	92	10	0.925	10			
	FRN030G11S-2UX			1912(216)	1584(179)	110	10	1.1	10			
	FRN007P11S-2UX	-	-	DB3.7-2C	1	33	320(36.2)	266(30.0)	37	15	0.185	10
	FRN010P11S-2UX						439(49.6)	363(41.0)	55	15	0.275	10
	FRN015P11S-2UX						637(72.0)	528(59.7)	37	7	0.375	10
	FRN020P11S-2UX						868(98.1)	720(81.4)	55	7	0.55	10
	FRN025P11S-2UX						1071(121)	885(100)	75	7	0.75	7
	FRN030P11S-2UX						1275(144)	1053(119)	93	7	0.925	7

NOTE: • Refer to Selection procedure and Notes on Selection.
• Maximum braking torque is based on the rated torque run by a commercial power supply.

[460V]

■FRN □□□ G11S-4 series, FRN □□□ P11S-4 series

Table 3.12 Braking unit and braking resistor (G11S 400V)

Power supply voltage	Inverter type	Option					Maximum braking torque [%]		Cont. braking (100% torque conversion value)		Repetitive braking (100s or less cycle)	
		Braking unit		Braking resistor			50Hz [lb-in (N·m)]	60Hz [lb-in (N·m)]	Discharging capability [kW]	Braking time [s]	Average loss [kW]	Duty cycle (%)
		Type	Q'ty	Type	Q'ty	Total ohmic value [Ω]	[N·m]	[N·m]				
Three-phase 460V	FRNF50G11S-4UX	-	-	DB0.75-4C	1	200	35.6(4.02)	29.4(3.32)	9	45	0.02	10
	FRN001G11S-4UX						67.0(7.57)	55.3(6.25)	17	45	0.0375	10
	FRN002G11S-4UX						133(15.0)	110(12.4)	34	45	0.075	10
	FRN003G11S-4UX						195(22.0)	161(18.2)	33	30	0.11	10
	FRN005G11S-4UX						328(37.1)	270(30.5)	37	20	0.185	10
	FRN007G11S-4UX						481(54.3)	398(45.0)	55	20	0.275	10
	FRN010G11S-4UX			659(74.4)	545(61.6)	38	10	0.375	10			
	FRN015G11S-4UX			956(108)	792(89.5)	55	10	0.55	10			
	FRN020G11S-4UX			1301(147)	1080(122)	75	10	0.75	10			
	FRN025G11S-4UX			1611(182)	1337(151)	92	10	0.925	10			
	FRN030G11S-4UX			1912(216)	1584(179)	110	10	1.1	10			
	FRN007P11S-4UX			-	-	DB3.7-4C	1	130	320(36.2)	266(30.0)	37	15
	FRN010P11S-4UX	439(49.6)	363(41.0)						55	15	0.275	10
	FRN015P11S-4UX	637(72.0)	528(59.7)						38	7	0.375	10
	FRN020P11S-4UX	868(98.1)	720(81.4)						55	7	0.55	10
	FRN025P11S-4UX	1071(121)	885(100)						75	7	0.75	7
	FRN030P11S-4UX	1275(144)	1053(119)						93	7	0.925	7

NOTE: • Refer to Selection procedure and Notes on Selection.
• Maximum braking torque is based on the rated torque run by a commercial power supply.

5. Braking Unit and Braking Resistor (10% ED)

- Dimensions, inch (mm)
- Braking resistor (10% ED)
DB0.75-2C to DB22-2C
DB0.75-4C to DB22-4C

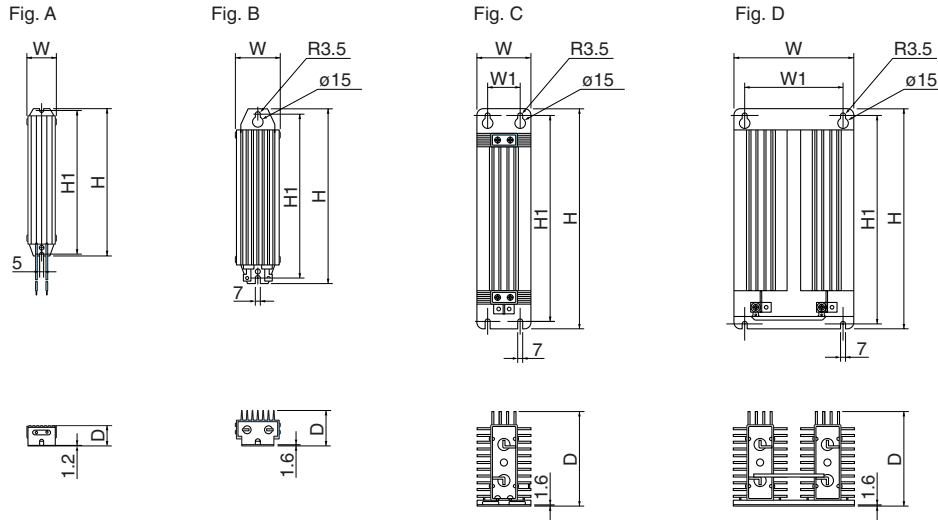

Braking resistor type		Fig.	Dimensions [inch (mm)]				
230V	460V		W	W1	H	H1	D
DB0.75-2C	DB0.75-4C	A	1.69(43)		8.7(221)	8.46(215)	1.2(30.5)
DB2.2-2C	DB2.2-4C	B	2.64(67)	-	7.4(188)	6.77(172)	2.17(55)
DB3.7-2C	DB3.7-4C				12.91(328)	12.28(312)	
DB5.5-2C	DB5.5-4C				14.88(378)	14.25(362)	3.07(78)
DB7.5-2C	DB7.5-4C				16.46(418)	15.83(402)	
DB11-2C	DB11-4C	C	3.15(80)	1.97(50)	18.11(460)	17.32(440)	5.51(140)
DB15-2C	DB15-4C				22.83(580)	22.05(560)	
DB22-2C	DB22-4C	D	7.09(180)	5.67(144)	15.75(400)	15.08(383)	5.71(145)

6. Rated Sensitive Current of GFCI

6. Rated Sensitive Current of GFCI

Table 3.14 Rated sensitive current of GFCI

Power supply voltage	Nominal applied motor [HP]	Inverter type		Rated current of nominal applied motor [A]	Wiring length and sensitive current						
		G11S series	P11S series		10m	30m	50m	100m	200m	300m	
Three-phase 230V	1/4	FRNF25G11S-2UX	-	1.4							
	1/2	FRNF50G11S-2UX		2.3							
	1	FRN001G11S-2UX		3.6							
	2	FRN002G11S-2UX		6.5							
	3	FRN003G11S-2UX		9.2							
	5	FRN005G11S-2UX		15							
	7.5	FRN007G11S-2UX	FRN007P11S-2UX	22							
	10	FRN010G11S-2UX	FRN010P11S-2UX	29							
	15	FRN015G11S-2UX	FRN015P11S-2UX	42							
	20	FRN020G11S-2UX	FRN020P11S-2UX	55							
	25	FRN025G11S-2UX	FRN025P11S-2UX	67							
	30	FRN030G11S-2UX	FRN030P11S-2UX	78							
	40	FRN040G11S-2UX	FRN040P11S-2UX	107							
	50	FRN050G11S-2UX	FRN050P11S-2UX	130							
	60	FRN060G11S-2UX	FRN060P11S-2UX	156							
75	FRN075G11S-2UX	FRN075P11S-2UX	198								
100	FRN100G11S-2UX	FRN100P11S-2UX	271								
125	FRN125G11S-2UX	FRN125P11S-2UX	315								
150	-	FRN150P11S-2UX	383								
Three-phase 460V	1/2	FRNF50G11S-4UX	-	1.2							
	1	FRN001G11S-4UX		1.8							
	2	FRN002G11S-4UX		3.3							
	3	FRN003G11S-4UX		4.6							
	5	FRN005G11S-4UX		7.5							
	7.5	FRN007G11S-4UX	FRN007P11S-4UX	11							
	10	FRN010G11S-4UX	FRN010P11S-4UX	14.5							
	15	FRN015G11S-4UX	FRN015P11S-4UX	21							
	20	FRN020G11S-4UX	FRN020P11S-4UX	27.5							
	25	FRN025G11S-4UX	FRN025P11S-4UX	34							
	30	FRN030G11S-4UX	FRN030P11S-4UX	39							
	40	FRN040G11S-4UX	FRN040P11S-4UX	54							
	50	FRN050G11S-4UX	FRN050P11S-4UX	65							
	60	FRN060G11S-4UX	FRN060P11S-4UX	78							
	75	FRN075G11S-4UX	FRN075P11S-4UX	99							
	100	FRN100G11S-4UX	FRN100P11S-4UX	135							
	125	FRN125G11S-4UX	FRN125P11S-4UX	160							
	150	FRN150G11S-4UX	FRN150P11S-4UX	192							
	200	FRN200G11S-4UX	FRN200P11S-4UX	226							
	250	FRN250G11S-4UX	FRN250P11S-4UX	265							
300	FRN300G11S-4UX	FRN300P11S-4UX	336								
350	FRN350G11S-4UX	FRN350P11S-4UX	396								
400	FRN400G11S-4UX	FRN400P11S-4UX	500								
450	FRN450G11S-4UX	FRN450P11S-4UX									
500	FRN500G11S-4UX	FRN500P11S-4UX									
600	FRN600G11S-4UX	FRN600P11S-4UX									
700		FRN700P11S-4UX									
800	-	FRN800P11S-4UX									

NOTE: Rated current of nominal applied motor is based on the value of Fuji standard motor (4 pole, 230V, 50Hz).

7. Input Circuit Noise Filter (EMC Compliance Filter)

7. Input Circuit Noise Filter (EMC Compliance Filter)

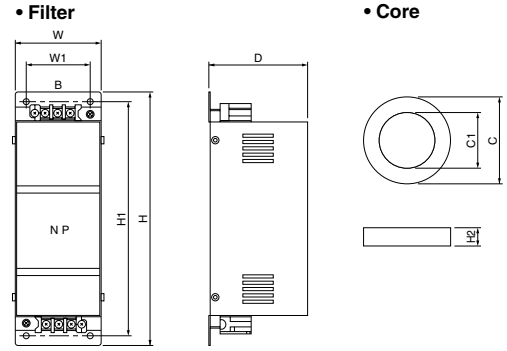

Table 3.15 Input circuit noise filter (EMC Compliance Filter, 230V)

Power supply voltage	Nominal applied motor [HP]	Inverter type		Filter			Core		Filter					Core																								
		G11S series	P11S series	Type	Rated voltage [V]	Rated current [A]	Leakage current [mA]	Type	Q'ty	Dimensions [inch(mm)]					Dimensions [inch(mm)]																							
										W	W1	H	H1	D	Weight [lbs(kg)]	C	C1	H2																				
Three-phase 230V	1/4	FRNF25G11S-2UX	-	EFL-0.75SP-2	200 to 230	6	4.2	OF1	1	3.35	2.32	9.57	8.98	3.66	3.3	2.01	0.98	0.67																				
	(85)	(59)								(243)	(228)	(93)	(1.5)	(51)	(25)	(17)																						
	1/2	FRNF50G11S-2UX								EFL-3.75SP-2	25	9	OF2	1	4.13	3.15	9.17	8.46	5.35	5.5	2.72	1.69	0.63															
	(105)	(80)													(233)	(215)	(136)	(2.5)	(69)	(43)	(16)																	
	1	FRN001G11S-2UX													EFL-7.5SP-2	50	23	OF3	1	4.72	3.74	10.75	10.00	6.22	11	3.82	2.95	0.98										
	(120)	(95)																		(273)	(254)	(158)	(5.0)	(97)	(75)	(25)												
	2	FRN002G11S-2UX																		EFL-15SP-2	100	23	OF3	1	8.07	6.30	20.20	19.17	7.60	44	3.82	2.95	0.98					
	(205)	(160)																							(513)	(487)	(193)	(20)	(97)	(75)	(25)							
	3	FRN003G11S-2UX																							EFL-22SP-2	150	23	OF3	1	8.07	6.30	20.20	19.17	7.60	44	3.82	2.95	0.98
	(205)	(160)																												(513)	(487)	(193)	(20)	(97)	(75)	(25)		
5	FRN005G11S-2UX	EFL-22SP-2	150	23	OF3	1	8.07	6.30	20.20																					19.17	7.60	44	3.82	2.95	0.98			
(205)	(160)						(513)	(487)	(193)																					(20)	(97)	(75)	(25)					
7.5	FRN007G11S-2UX						EFL-22SP-2	150	23	OF3	1	8.07	6.30	20.20																19.17	7.60	44	3.82	2.95	0.98			
(205)	(160)											(513)	(487)	(193)																(20)	(97)	(75)	(25)					
10	FRN010G11S-2UX											EFL-22SP-2	150	23	OF3	1	8.07	6.30	20.20											19.17	7.60	44	3.82	2.95	0.98			
(205)	(160)																(513)	(487)	(193)											(20)	(97)	(75)	(25)					
15	FRN015G11S-2UX																EFL-22SP-2	150	23	OF3	1	8.07	6.30	20.20						19.17	7.60	44	3.82	2.95	0.98			
(205)	(160)																					(513)	(487)	(193)						(20)	(97)	(75)	(25)					
20	FRN020G11S-2UX																					EFL-22SP-2	150	23	OF3	1	8.07	6.30	20.20	19.17	7.60	44	3.82	2.95	0.98			
(205)	(160)																										(513)	(487)	(193)	(20)	(97)	(75)	(25)					
25	FRN025G11S-2UX	EFL-22SP-2	150	23	OF3	1																					8.07	6.30	20.20	19.17	7.60	44	3.82	2.95	0.98			
(205)	(160)																										(513)	(487)	(193)	(20)	(97)	(75)	(25)					
30	FRN030G11S-2UX						EFL-22SP-2	150	23	OF3	1																8.07	6.30	20.20	19.17	7.60	44	3.82	2.95	0.98			
(205)	(160)																										(513)	(487)	(193)	(20)	(97)	(75)	(25)					

Fig. A

Fig. B

Fig. C

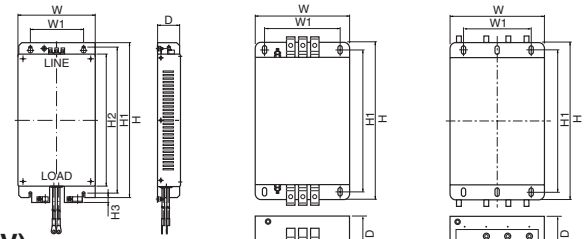

Table 3.16 Input circuit noise filter (EMC Compliance Filter, 460V)

Power supply voltage	Nominal applied motor [HP]	Inverter type		EMC filter Type	Rated voltage [V]	Rated current [A]	Leakage current [mA]	Fig	Dimensions [inch (mm)]																							
		G11S series	P11S series						W	W1	H	H1	H2	H3	D	Mtg, screw																
Three-phase 460V	1/2	FRNF50G11S-4UX	-	EFL-0.75G11-4	380 to 480	5	72	A	4.57	3.54	12.20	11.54	10.43	0.39	1.65	M5																
	(116)	(90)							(310)	(293)	(265)	(10)	(42)																			
	1	FRN001G11S-4UX							EFL-4.0G11-4	12	105	A	6.10	4.13	12.20	11.54	10.43	0.39	1.77	M5												
	(155)	(105)											(310)	(293)	(265)	(10)	(45)															
	2	FRN002G11S-4UX											EFL-7.5G11-4	35	105	A	8.86	6.57	13.03	12.24	10.24	0.39	1.87	M8								
	(225)	(167)															(331)	(311)	(260)	(10)	(47.5)											
	3	FRN003G11S-4UX															EFL-15G11-4	50	158	A	9.84	7.28	18.90	17.68	15.75	0.79	2.76	M8				
	(250)	(185)																			(480)	(449)	(400)	(20)	(70)							
	5	FRN005G11S-4UX																			EFL-22G11-4	72	105	A	9.84	7.28	18.90	17.68	15.75	0.79	2.76	M8
	(250)	(185)																							(480)	(449)	(400)	(20)	(70)			
	7.5	FRN007G11S-4UX	RF-3100-F11	100	130	B	7.87	6.54																	17.13	16.06	-	-	5.12	M6		
	(200)	(166)					(435)	(408)																			(130)					
	10	FRN010G11S-4UX					RF-3180-F11	180	130	B	7.87	6.54													19.49	18.43	-	-	6.30	M6		
	(200)	(166)									(495)	(468)															(160)					
	15	FRN015G11S-4UX									RF-3280-F11	280	270	C	9.84	6.69									23.11	22.05	-	-	8.07	M6		
	(250)	(170)													(587)	(560)											(205)					
	20	FRN020G11S-4UX													RF-3400-F11	400	270	C	9.84	6.69					23.11	22.05	-	-	8.07	M6		
	(250)	(170)																	(587)	(560)							(205)					
	25	FRN025G11S-4UX																	RF-3880-F11	880	270	C	14.33	11.81	27.09	25.51	-	-	7.09	M8		
	(364)	(300)																					(688)	(648)			(180)					
30	FRN030G11S-4UX	RF-3880-F11	880	270	C	14.33																	11.81	27.09	25.51	-	-	7.09	M8			
(364)	(300)					(688)																	(648)			(180)						
40	FRN040G11S-4UX					RF-3880-F11	880	270	C	14.33													11.81	27.09	25.51	-	-	7.09	M8			
(364)	(300)									(688)													(648)			(180)						
50	FRN050G11S-4UX									RF-3880-F11	880	270	C	14.33									11.81	27.09	25.51	-	-	7.09	M8			
(364)	(300)													(688)									(648)			(180)						
60	FRN060G11S-4UX													RF-3880-F11	880	270	C	14.33					11.81	27.09	25.51	-	-	7.09	M8			
(364)	(300)																	(688)					(648)			(180)						
75	FRN075G11S-4UX																	RF-3880-F11	880	270	C	14.33	11.81	27.09	25.51	-	-	7.09	M8			
(364)	(300)																					(688)	(648)			(180)						
100	FRN100G11S-4UX	RF-3880-F11	880	270	C																	14.33	11.81	27.09	25.51	-	-	7.09	M8			
(364)	(300)																					(688)	(648)			(180)						
125	FRN125G11S-4UX					RF-3880-F11	880	270	C													14.33	11.81	27.09	25.51	-	-	7.09	M8			
(364)	(300)																					(688)	(648)			(180)						
150	FRN150G11S-4UX									RF-3880-F11	880	270	C									14.33	11.81	27.09	25.51	-	-	7.09	M8			
(364)	(300)																					(688)	(648)			(180)						
200	FRN200G11S-4UX													RF-3880-F11	880	270	C					14.33	11.81	27.09	25.51	-	-	7.09	M8			
(364)	(300)																					(688)	(648)			(180)						
250	FRN250G11S-4UX																	RF-3880-F11	880	270	C	14.33	11.81	27.09	25.51	-	-	7.09	M8			
(364)	(300)																					(688)	(648)			(180)						
300	FRN300G11S-4UX	RF-3880-F11	880	270	C																	14.33	11.81	27.09	25.51	-	-	7.09	M8			
(364)	(300)																					(688)	(648)			(180)						
350	FRN350G11S-4UX					RF-3880-F11	880	270	C													14.33	11.81	27.09	25.51	-	-	7.09	M8			
(364)	(300)																					(688)	(648)			(180)						
400	FRN400G11S-4UX									RF-3880-F11	880	270	C									14.33	11.81	27.09	25.51	-	-	7.09	M8			
(364)	(300)																					(688)	(648)			(180)						
450	FRN450G11S-4UX													RF-3880-F11	880	270	C					14.33	11.81	27.09	25.51	-	-	7.09	M8			
(364)	(300)																					(688)	(648)			(180)						
500	FRN500G11S-4UX																	RF-3880-F11	880	270	C	14.33	11.81	27.09	25.51	-	-	7.09	M8			
(364)	(300)																					(688)	(648)			(180)						
600	FRN600G11S-4UX	RF-3880-F11	880	270	C																	14.33	11.81	27.09	25.51	-	-	7.09	M8			
(364)	(300)																					(688)	(648)			(180)						
700	FRN700P11S-4UX					RF-3880-F11	880	270	C													14.33	11.81	27.09	25.51	-	-	7.09	M8			
(364)	(300)																					(688)	(648)			(180)						
800	FRN800P11S-4UX									RF-3880-F11	880	270	C									14.33	11.81	27.09	25.51	-	-	7.09	M8			
(364)	(300)																					(688)	(648)			(180)						

Contact Fuji

8. Output Circuit Noise Filter (OFL- □ □ -2/4)

8. Output Circuit Noise Filter (OFL- □ □ -2/4)

Table 3.18 Output circuit noise filter (OFL- □ □ -2/4)

Power supply voltage	Nominal applied motor [HP]	Inverter type		Filter type	Rated current [A]	Overload capability	Inverter power input voltage	Maximum frequency	Carrier frequency allowable range *4)	Approx. Weight [lbs (kg)]
		G11S series	P11S series							
Three-phase 230V	1/4	FRNF25G11S-2UX	-	OFL-0.4-2	3	150% for 60s, 200% for 0.5s	3-phase 200 to 230V 50/60Hz	400Hz	8 to 15kHz	15(7)
	1/2	FRNF50G11S-2UX		OFL-1.5-2	8					21(9.5)
	1	FRN001G11S-2UX		OFL-3.7-2	17					33(15)
	2	FRN002G11S-2UX		OFL-7.5-2	33					51(23)
	3	FRN003G11S-2UX		OFL-15-2	59					84(38)
	5	FRN005G11S-2UX		OFL-22-2	87					101(46)
		7.5	FRN007G11S-2UX	FRN007P11S-2UX	OFL-30-2	115	150% for 60s, 180% for 0.5s	120Hz	6kHz or higher	84(38)
		10	FRN010G11S-2UX	FRN010P11S-2UX	OFL-37-2	145				97(44)
		15	FRN015G11S-2UX	FRN015P11S-2UX	OFL-45-2	180				106(48)
		20	FRN020G11S-2UX	FRN020P11S-2UX	OFL-55-2	215				146(66)
		25	FRN025G11S-2UX	FRN025P11S-2UX	OFL-75-2	285				192(78)
		30	FRN030G11S-2UX	FRN030P11S-2UX	OFL-90-2	Contact Fuji				
		40	FRN040G11S-2UX	FRN040P11S-2UX	OFL-110-2					
		50	FRN050G11S-2UX	FRN050P11S-2UX	OFL-110-2	Contact Fuji				
		60	FRN060G11S-2UX	FRN060P11S-2UX	OFL-110-2					
		75	FRN075G11S-2UX	FRN075P11S-2UX	OFL-110-2	Contact Fuji				
	100	FRN100G11S-2UX	FRN100P11S-2UX	OFL-110-2						
	125	FRN125G11S-2UX	FRN125P11S-2UX	OFL-110-2	Contact Fuji					
	150	-	FRN150P11S-2UX	OFL-110-2						
Three-phase 460V	1/2	FRNF50G11S-4UX	-	OFL-0.4-4	1.5	150% for 60s, 200% for 0.5s	3-phase 380 to 460V 50/60Hz	400Hz	8 to 15kHz	15(7)
	1	FRN001G11S-4UX		OFL-1.5-4	3.7					15(7)
	2	FRN002G11S-4UX		OFL-3.7-4	9					26(12)
	3	FRN003G11S-4UX		OFL-7.5-4	18					42(19)
		5	FRN005G11S-4UX	FRN007P11S-4UX	OFL-15-4	30	150% for 60s, 180% for 0.5s	120Hz	6kHz or higher	73(33)
		7.5	FRN007G11S-4UX	FRN010P11S-4UX	OFL-22-4	45				95(43)
		10	FRN010G11S-4UX	FRN015P11S-4UX	OFL-30-4	60				84(38)
		15	FRN015G11S-4UX	FRN020P11S-4UX	OFL-37-4	75				101(46)
		20	FRN020G11S-4UX	FRN025P11S-4UX	OFL-45-4	91				121(55)
		25	FRN025G11S-4UX	FRN030P11S-4UX	OFL-55-4	112				150(68)
		30	FRN030G11S-4UX	FRN040P11S-4UX	OFL-75-4	150	176(80)			
		40	FRN040G11S-4UX	FRN050P11S-4UX	OFL-90-4	176	216(98)			
		50	FRN050G11S-4UX	FRN060P11S-4UX	OFL-110-4	210	254(115)			
		60	FRN060G11S-4UX	FRN075P11S-4UX	OFL-132-4	253	287(130)			
		75	FRN075G11S-4UX	FRN100P11S-4UX	OFL-160-4	304	342(155)			
		100	FRN100G11S-4UX	FRN125P11S-4UX	OFL-200-4	377	408(185)			
		125	FRN125G11S-4UX	FRN150P11S-4UX	OFL-220-4	415	441(200)			
		150	FRN150G11S-4UX	FRN200P11S-4UX	OFL-280-4	Contact Fuji				
		200	FRN200G11S-4UX	FRN250P11S-4UX	OFL-315-4					
		250	FRN250G11S-4UX	FRN300P11S-4UX	OFL-355-4					
	300	FRN300G11S-4UX	FRN350P11S-4UX	OFL-400-4						
	350	FRN350G11S-4UX	FRN400P11S-4UX	OFL-450-4						
	400	FRN400G11S-4UX	FRN450P11S-4UX	OFL-500-4						
	450	FRN450G11S-4UX	FRN500P11S-4UX	OFL-500-4	Contact Fuji					
	500	FRN500G11S-4UX	FRN600P11S-4UX	OFL-500-4						
	600	FRN600G11S-4UX	FRN450P11S-4UX	OFL-500-4						
	700	-	FRN800P11S-4UX	OFL-500-4						
	800	-	FRN800P11S-4UX	OFL-500-4	Contact Fuji					

NOTES: • For the model of 40HP or larger, capacitor will be installed separately.
 • This filter should be used within the carrier frequency allowable range.

8. Output Circuit Noise Filter (OFL-□□-2/4)

■ Dimensions, mm
• Filter

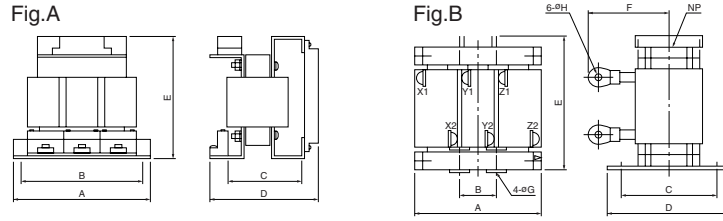

Power supply voltage	type	Fig.	A	B	C	D	E	F	Earth terminal	Terminal screw H	Mounting screw G	Approx. Weight [lbs(kg)]			
Three-phase 230V	OFL-0.4-2	A	8.66(220)	7.87(200)	3.74(95)	6.69(170)	7.68(195)	—	M4	M4	M5	15(7)			
	OFL-1.5-2				4.13(105)		8.46(215)					21(9.5)			
	OFL-3.7-2				5.31(135)	7.87(200)	33(15)								
	OFL-7.5-2				11.02(280)	9.84(250)	6.3(160)					9.84(250)	9.06(230)	51(23)	
	OFL-15-2				6.69(170)	10.63(270)	10.63(270)					12.60(320)	84(38)		
	OFL-22-2				11.81(300)	10.63(270)	7.09(180)					11.81(300)	12.99(330)	101(46)	
	OFL-30-2	B	11.02(280)	3.74(95)	7.87(200)	9.06(230)	13.58(345)	6.30(160)	—	0.25(6.4)	0.39(10)	84(38)			
	OFL-37-2				8.27(210)	9.45(240)	15.75(400)					97(44)			
	OFL-45-2				7.87(200)	15.75(400)	7.09(180)					106(48)			
	OFL-55-2				12.99(330)	4.33(110)	8.46(215)					10.04(255)	16.54(420)	7.09(180)	146(66)
OFL-75-2	9.45(240)				11.02(280)	16.93(430)	7.48(190)					172(78)			
Three-phase 460V	OFL-0.4-4	A	8.66(220)	7.87(200)	3.74(95)	6.69(170)	7.68(195)	—	M4	M4	M5	15(7)			
	OFL-1.5-4				4.53(115)	7.48(190)	8.86(225)					26(12)			
	OFL-3.7-4				11.42(290)	10.24(260)	5.51(140)					9.06(230)	9.06(230)	42(19)	
	OFL-7.5-4				12.99(330)	11.81(300)	5.71(145)					10.04(255)	12.20(310)	73(33)	
	OFL-15-4				6.69(170)	11.42(290)	12.99(330)					95(43)			
	OFL-22-4				11.02(280)	3.74(95)	7.87(200)					9.06(230)	13.58(345)	5.91(150)	84(38)
	OFL-30-4	B	11.02(280)	3.74(95)	8.46(215)	9.65(245)	13.98(355)	6.69(170)	—	0.25(6.4)	0.39(10)	101(46)			
	OFL-37-4				7.87(200)	9.45(240)	15.75(400)					121(55)			
	OFL-45-4				12.99(330)	4.33(110)	8.46(215)					10.04(255)	16.54(420)	7.09(180)	150(68)
	OFL-55-4				9.06(230)	10.63(270)	16.93(430)					7.48(190)	176(80)		
	OFL-75-4				14.17(360)	4.72(120)	10.24(260)					11.81(300)	18.90(480)	7.48(190)	216(98)
	OFL-90-4				10.83(275)	12.40(315)	19.29(490)					7.87(200)	254(115)		
	OFL-110-4				11.61(295)	13.19(335)	21.65(550)					8.27(210)	287(130)		
	OFL-132-4				11.22(285)	12.80(325)	22.44(570)					9.06(230)	342(155)		
	OFL-160-4				15.35(390)	5.12(130)	12.01(305)					13.58(345)	22.44(570)	9.06(230)	408(185)
	OFL-200-4				12.01(305)	13.58(345)	22.44(570)					9.45(240)	441(200)		
	OFL-220-4				16.54(420)	5.51(140)	12.2(310)					14.17(360)	22.83(580)	9.45(240)	441(200)

• Capacitor

The capacitor for the filter OFL-30-□ or larger has to be installed separately.
(The capacitor mass is not included in the filter mass on the above table.)

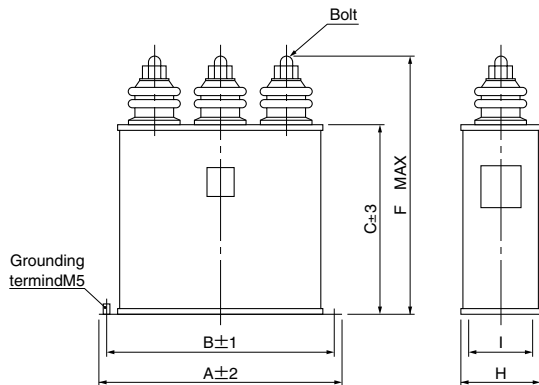

Power supply voltage	Filter type	Capacitor dimensions [inch(mm)]							
		A	B	C	F	H	I	Bolt	
Three-phase 230V	OFL-30-2	6.50(165)	5.91(150)	4.72(120)	5.91(150)	2.76(70)	1.57(40)	M5	
	OFL-37-2			5.91(150)	7.28(185)				
	OFL-45-2	8.07(205)	7.48(190)	5.91(150)	7.87(200)				M6
	OFL-55-2	11.02(280)	10.43(265)	7.09(180)	10.63(270)				
	OFL-75-2	0.41(10.5)	2.17(55)						
Three-phase 460V	OFL-30-4	6.50(165)	5.91(150)	3.94(100)	5.31(135)	2.76(70)	1.57(40)	M5	
	OFL-37-4			4.72(120)	6.10(155)				
	OFL-45-4			7.28(185)	7.87(200)				M6
	OFL-55-4			5.91(150)	7.87(200)				
	OFL-75-4	8.07(205)	7.48(190)	5.91(150)	7.87(200)			M12	
	OFL-90-4	7.09(180)	10.63(270)	3.54(90)	2.17(55)				
	OFL-110-4	7.87(200)	11.42(290)						
	OFL-132-4	11.02(280)	10.43(265)	7.87(200)	11.42(290)				
	OFL-160-4	9.06(230)	12.60(320)						
	OFL-200-4	9.06(230)	12.60(320)						

Chapter 3

9. Output Circuit Noise Filter (OFL- □ □ -4A)

9. Output Circuit Noise Filter (OFL- □ □ -4A)

Table 3.19 Output circuit noise filter (OFL- □ □ -4A)

Power supply voltage	Nominal applied motor [HP]	Inverter type		Filter type	Rated current [A]	Overload capability	Inverter power input voltage	Carrier frequency allowable range	Maximum frequency				
		G11S series	P11S series										
Three-phase 460V	1/2	FRNF50G11S-4UX	-	OFL-0.4-4A	1.5	150%- 1min, 200%- 0.5s	Three-phase 380 to 480V	0.75 to 15kHz	400Hz				
	1	FRN001G11S-4UX		OFL-1.5-4A	3.7								
	2	FRN002G11S-4UX		OFL-3.7-4A	9								
	3	FRN003G11S-4UX		OFL-7.5-4A	18								
	5	FRN005G11S-4UX		OFL-15-4A	30								
	7.5	FRN007G11S-4UX	FRN007P11S-4UX	OFL-22-4A	45								
	10	FRN010G11S-4UX	FRN010P11S-4UX	OFL-30-4A	60					150%- 1min, 180%- 0.5s	50/60HZ	0.75 to 10kHz	
	15	FRN015G11S-4UX	FRN015P11S-4UX	OFL-37-4A	75								
	20	FRN020G11S-4UX	FRN020P11S-4UX	OFL-45-4A	91								
	25	FRN025G11S-4UX	FRN025P11S-4UX	OFL-55-4A	112								
	30	FRN030G11S-4UX	FRN030P11S-4UX	OFL-75-4A	150								
	40	FRN040G11S-4UX	FRN040P11S-4UX	OFL-90-4A	176								
	50	FRN050G11S-4UX	FRN050P11S-4UX	OFL-110-4A	210								
	60	FRN060G11S-4UX	FRN060P11S-4UX	OFL-132-4A	253								
	75	FRN075G11S-4UX	FRN075P11S-4UX	OFL-160-4A	304								
	100	FRN100G11S-4UX	FRN100P11S-4UX	OFL-200-4A	377								
	125	FRN125G11S-4UX	FRN125P11S-4UX	OFL-220-4A	415								
	150	FRN150G11S-4UX	FRN150P11S-4UX	OFL-280-4A	520								
	200	FRN200G11S-4UX	FRN200P11S-4UX	OFL-315-4A									
	250	FRN250G11S-4UX	FRN250P11S-4UX	OFL-355-4A									
300	FRN300G11S-4UX	FRN300P11S-4UX	OFL-400-4A										
350	FRN350G11S-4UX	FRN350P11S-4UX	OFL-450-4A										
400	FRN400G11S-4UX	FRN400P11S-4UX	OFL-500-4A										
450	FRN450G11S-4UX	FRN450P11S-4UX											
500	FRN500G11S-4UX	FRN500P11S-4UX											
600	FRN600G11S-4UX	FRN600P11S-4UX											
700		FRN700P11S-4UX											
800		FRN800P11S-4UX											

NOTES: The capacitor for the filter OFL-30-4A or larger has to be installed separately. (The capacitor mass is not included in the filter mass on the table below.)

■ Dimensions, inch(mm)
• Filter

Fig.A

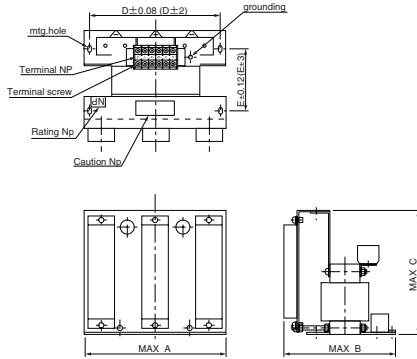

Fig.B

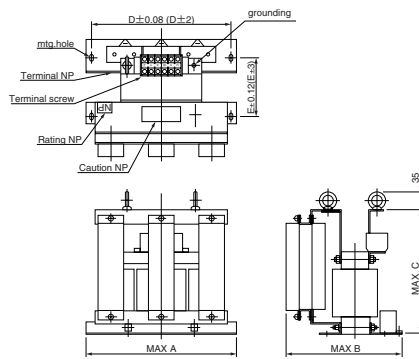

Fig.C

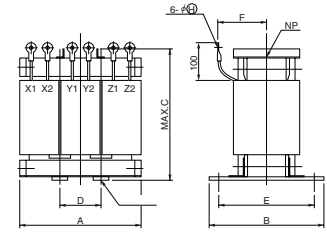

Fig.D

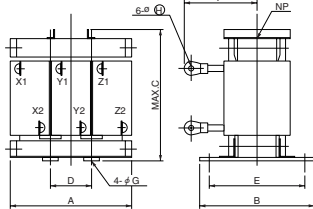
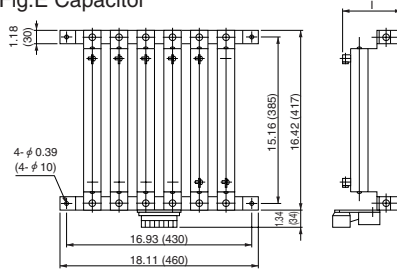

Fig.E Capacitor



The capacitor for the filter OFL-30-4A or larger has to be installed separately. (The capacitor mass is not included in the filter mass on the table below.)

Power supply voltage	Filter type	Fig.	Dimensions [inch(mm)]							Ground terminal	Terminal screw H	Mounting screw G	Approx. Weight [lbs(kg)]					
			A	B	C	D	E	F	I									
Three-phase 460V	OFL-0.4-4A	A	8.66(220)	6.89(175)	7.68(195)	7.87(200)	3.74(95)	-	-	M4	M4	M5	15(7)					
	OFL-1.5-4A			8.86(225)	8.66(220)		4.53(115)						15(7)					
	OFL-3.7-4A			11.42(290)	11.42(290)		9.06(230)						10.24(260)	6.30(160)	31(14)			
	OFL-7.5-4A	B	12.99(330)	10.83(275)	12.20(310)	11.81(300)	5.71(145)	-	-	M5	M5	M6	49(22)					
	OFL-15-4A		11.81(300)	12.99(330)	11.81(300)	6.69(170)	77(35)											
	OFL-22-4A	C	12.99(330)	11.81(300)	12.99(330)	11.81(300)	6.69(170)	6.30(160)	-	-	M6	M6	M8	99(45)				
	OFL-30-4A		8.27(210)	6.89(175)	8.27(210)	2.76(70)	5.51(140)							3.54(90)	26(12)			
	OFL-37-4A		8.66(220)	7.48(190)	8.66(220)	2.95(75)	5.91(150)							3.74(95)	0.25(6.4)	0.31(8)	33(15)	
	OFL-45-4A		8.66(220)	7.68(195)	10.43(265)	2.76(70)	6.10(155)							5.51(140)	0.33(8.4)	0.39(10)	37(17)	
	OFL-55-4A		10.24(260)	7.87(200)	10.83(275)	3.35(85)	6.30(160)							5.91(150)			49(22)	
	OFL-75-4A		10.24(260)	8.27(210)	11.42(290)		6.69(170)							6.10(155)	9.17(233)	0.41(10.5)	0.47(12)	55(25)
	OFL-90-4A		11.81(300)	9.06(230)	12.99(330)	7.48(190)	6.69(170)							13.11(333)				-
	OFL-110-4A		11.81(300)	9.45(240)	13.39(340)	3.94(100)	7.87(200)								7.09(180)	0.51(13)	0.59(15)	
	OFL-132-4A		12.60(320)	10.63(270)	13.78(350)	4.13(105)	8.66(220)							7.48(190)	-			-
	OFL-160-4A		13.39(340)	11.81(300)	15.35(390)	4.53(115)	9.84(250)							7.87(200)		-	-	
	OFL-200-4A	13.78(350)	11.81(300)	16.93(430)	4.53(115)	9.84(250)	7.87(200)	-	-	-	132(60)							
OFL-220-4A	13.78(350)	11.81(300)	16.93(430)	4.53(115)	9.84(250)	7.87(200)	-				-	-	154(70)					
OFL-280-4A	13.78(350)	11.81(300)	16.93(430)	4.53(115)	9.84(250)	7.87(200)		-	-	-			172(78)					

10. DC REACTOR (DCR)

■ This REACTOR is mainly used for normalizing the power supply or improving power-factor (reducing harmonics).

Table 3.20 DC REACTOR (DCR), G11S/P11S series

Power supply	Nominal applied motor [HP]	Inverter type		DC REACTOR (DCR)			
		G11S series	P11S series	Type	Rated current [A]	Inductance [mH]	Generated loss [W]
Three-phase 230V	1/4	FRNF25G11S-2UX	-	DCR2-0.2	1.5	20	1.2
	1/2	FRNF50G11S-2UX		DCR2-0.4	3.0	12	1.7
	1	FRN001G11S-2UX		DCR2-0.75	5.0	7.0	2.7
	2	FRN002G11S-2UX		DCR2-1.5	8.0	4.0	4.2
	3	FRN003G11S-2UX		DCR2-2.2	11	3.0	6.5
	5	FRN005G11S-2UX		DCR2-3.7	18	1.7	9.1
	7.5	FRN007G11S-2UX	FRN007P11S-2UX	DCR2-5.5	25	1.2	14
	10	FRN010G11S-2UX	FRN010P11S-2UX	DCR2-7.5	34	0.8	16
	15	FRN015G11S-2UX	FRN015P11S-2UX	DCR2-11	50	0.6	24
	20	FRN020G11S-2UX	FRN020P11S-2UX	DCR2-15	67	0.4	28
	25	FRN025G11S-2UX	FRN025P11S-2UX	DCR2-18.5	81	0.35	31
	30	FRN030G11S-2UX	FRN030P11S-2UX	DCR2-22A	98	0.3	37
	40	FRN040G11S-2UX	FRN040P11S-2UX	DCR2-30B	136	0.23	37
	50	FRN050G11S-2UX	FRN050P11S-2UX	DCR2-37B	167	0.19	47
	60	FRN060G11S-2UX	FRN060P11S-2UX	DCR2-45B	203	0.16	52
	75	FRN075G11S-2UX	FRN075P11S-2UX	DCR2-55B	244	0.13	55
	100	FRN100G11S-2UX	FRN100P11S-2UX	DCR2-75B	341	0.080	55
125	FRN125G11S-2UX	FRN125P11S-2UX	DCR2-90B	410	0.067	57	
150	-	FRN150P11S-2UX	DCR2-110B	526	0.055	67	
Three-phase 460V	1/2	FRNF50G11S-4UX	-	DCR4-0.4	1.5	50	1.5
	1	FRN001G11S-4UX		DCR4-0.75	2.5	30	2.1
	2	FRN002G11S-4UX		DCR4-1.5	4.0	16	4.6
	3	FRN003G11S-4UX		DCR4-2.2	5.5	12	6.7
	5	FRN005G11S-4UX		DCR4-3.7	9.0	7.0	8.5
	7.5	FRN007G11S-4UX	FRN007P11S-4UX	DCR4-5.5	13	4.0	9.3
	10	FRN010G11S-4UX	FRN010P11S-4UX	DCR4-7.5	18	3.5	15
	15	FRN015G11S-4UX	FRN015P11S-4UX	DCR4-11	25	2.2	20
	20	FRN020G11S-4UX	FRN020P11S-4UX	DCR4-15	34	1.8	28
	25	FRN025G11S-4UX	FRN025P11S-4UX	DCR4-18.5	41	1.4	29
	30	FRN030G11S-4UX	FRN030P11S-4UX	DCR4-22A	49	1.2	35
	40	FRN040G11S-4UX	FRN040P11S-4UX	DCR4-30B	71	0.86	35
	50	FRN050G11S-4UX	FRN050P11S-4UX	DCR4-37B	88	0.70	40
	60	FRN060G11S-4UX	FRN060P11S-4UX	DCR4-45B	107	0.58	44
	75	FRN075G11S-4UX	FRN075P11S-4UX	DCR4-55B	131	0.47	55
	100	FRN100G11S-4UX	FRN100P11S-4UX	DCR4-75B	178	0.335	58
	125	FRN125G11S-4UX	FRN125P11S-4UX	DCR4-90B	214	0.29	64
	150	FRN150G11S-4UX	FRN150P11S-4UX	DCR4-110B	261	0.24	73
	200	FRN200G11S-4UX	FRN200P11S-4UX	DCR4-132B	313	0.215	84
	250	FRN250G11S-4UX	FRN250P11S-4UX	DCR4-160B	380	0.177	90
300	FRN300G11S-4UX	FRN300P11S-4UX	DCR4-200B	475	0.142	126	
350	FRN350G11S-4UX	FRN350P11S-4UX	DCR4-220B	524	0.126	131	
400	FRN400G11S-4UX	FRN400P11S-4UX	DCR4-280B	649	0.100	150	
450	FRN450G11S-4UX	FRN450P11S-4UX	DCR4-315B	739	0.089	190	
500	FRN500G11S-4UX	FRN500P11S-4UX	DCR4-355B	833	0.079	205	
600	FRN600G11S-4UX	FRN600P11S-4UX	DCR4-400B	938	0.070	215	
700	-	FRN700P11S-4UX	DCR4-450B	1056	0.063	272	
800	-	FRN800P11S-4UX	DCR4-500B	1173	0.057	292	

NOTE: The generated loss is an approximate value calculated by the following conditions:

- Power supply voltage is 230V or 460V, 50Hz. Voltage unbalance is 0(zero) %.
- Power transformer capacity is 500kVA, or 10 times of inverter rated capacity; which is larger one is adopted.
- The load motor is 4 pole standard motor with 100% load.
- No AC reactor (ACR) is connected.
- For the model of 100HP or larger, provided with DC REACTOR (DCR) as standard.

11. AC Reactor (ACR)

■ This reactor is unnecessary unless an especially stable power supply such as DC-bus connection operation (PN-connection operation) is required. Use a DC REACTOR (DCR) for reducing harmonics.

Table 3.22 AC reactor (ACR)

Power supply voltage	Nominal applied motor [HP]	Inverter type		AC REACTOR (ACR)					
		G11S series	P11S series	Type	Rated current [A]	Reactance [mΩ/phase] 50Hz	60Hz	Coil resistance [mΩ]	Generated loss [W] *1)
Three-phase 230V	1/4	FRNF25G11S-2UX	-	ACR2-0.4A	3	917	1100	-	5
	1/2	FRNF50G11S-2UX							10
	1	FRN001G11S-2UX							12
	2	FRN002G11S-2UX							14
	3	FRN003G11S-2UX							16
	5	FRN005G11S-2UX							23
	7.5	FRN007G11S-2UX	FRN007P11S-2UX	ACR2-5.5A	25	87.7	105	-	27
	10	FRN010G11S-2UX	FRN010P11S-2UX	ACR2-7.5A	33	65.0	78.0	-	30
	15	FRN015G11S-2UX	FRN015P11S-2UX	ACR2-11A	46	45.5	54.7	-	37
	20	FRN020G11S-2UX	FRN020P11S-2UX	ACR2-15A	59	34.8	41.8	-	43
	25	FRN025G11S-2UX	FRN025P11S-2UX	ACR2-18.5A	74	28.6	34.3	-	51
	30	FRN030G11S-2UX	FRN030P11S-2UX	ACR2-22A	87	24.0	28.8	-	57
	40	FRN040G11S-2UX	FRN040P11S-2UX	ACR2-37	200	10.8	13.0	0.5	28.6
	50	FRN050G11S-2UX	FRN050P11S-2UX						40.8
	60	FRN060G11S-2UX	FRN060P11S-2UX	ACR2-55	270	7.50	9.00	0.375	47.1
	75	FRN075G11S-2UX	FRN075P11S-2UX						66.1
	100	FRN100G11S-2UX	FRN100P11S-2UX	ACR2-75	390	5.45	6.54	0.250	55.1
125	FRN125G11S-2UX	FRN125P11S-2UX	ACR2-90	450	4.73	5.67	0.198	61.5	
150	-	FRN150P11S-2UX	ACR2-110	500	4.25	5.10	0.180	83.4	
Three-phase 460V	1/2	FRNF50G11S-4UX	-	ACR4-0.75A	2.5	1920	2300	-	5
	1	FRN001G11S-4UX							10
	2	FRN002G11S-4UX							11
	3	FRN003G11S-4UX							14
	5	FRN005G11S-4UX							17
	7.5	FRN007G11S-4UX	FRN007P11S-4UX	ACR4-5.5A	13	349	418	-	22
	10	FRN010G11S-4UX	FRN010P11S-4UX	ACR4-7.5A	18	256	307	-	27
	15	FRN015G11S-4UX	FRN015P11S-4UX	ACR4-11A	24	183	219	-	40
	20	FRN020G11S-4UX	FRN020P11S-4UX	ACR4-15A	30	139	167	-	46
	25	FRN025G11S-4UX	FRN025P11S-4UX	ACR4-18.5A	39	114	137	-	57
	30	FRN030G11S-4UX	FRN030P11S-4UX	ACR4-22A	45	95.8	115	-	62
	40	FRN040G11S-4UX	FRN040P11S-4UX	ACR4-37	100	41.7	50	2.73	38.9
	50	FRN050G11S-4UX	FRN050P11S-4UX						55.7
	60	FRN060G11S-4UX	FRN060P11S-4UX	ACR4-55	135	30.8	37	1.61	50.2
	75	FRN075G11S-4UX	FRN075P11S-4UX						70.7
	100	FRN100G11S-4UX	FRN100P11S-4UX	ACR4-75	160	25.8	31	1.16	65.3
	125	FRN125G11S-4UX	FRN125P11S-4UX	ACR4-110	250	16.7	20	0.523	42.2
	150	FRN150G11S-4UX	FRN150P11S-4UX						60.3
	200	FRN200G11S-4UX	FRN200P11S-4UX	ACR4-132	270	20.8	25	0.741	119
	250	FRN250G11S-4UX	FRN250P11S-4UX	ACR4-220 *2)	561	10.0	12	0.236	56.4
	300	FRN300G11S-4UX	FRN300P11S-4UX						90.4
	350	FRN350G11S-4UX	FRN350P11S-4UX						107
400	FRN400G11S-4UX	FRN400P11S-4UX	108						
450	FRN450G11S-4UX	FRN450P11S-4UX							
500	FRN500G11S-4UX	FRN500P11S-4UX	Contact Fuji						
600	FRN600G11S-4UX	FRN600P11S-4UX							
700	-	FRN700P11S-4UX							
800	-	FRN800P11S-4UX							

NOTE: *1) The generated loss is an approximate value calculated by the following conditions:

*2) Fan cooling is required. (3m/s or over).

- Power supply voltage is 230V or 460V, 50Hz. Voltage unbalance is 0(zero) %.
- Power transformer capacity is 500kVA, or 10 times of inverter rated capacity; which is larger one is adopted.
- The load motor is 4 pole standard motor with 100% load.

Chapter 3

11. AC Reactor (ACR)

■ Dimensions of AC reactor (ACR)

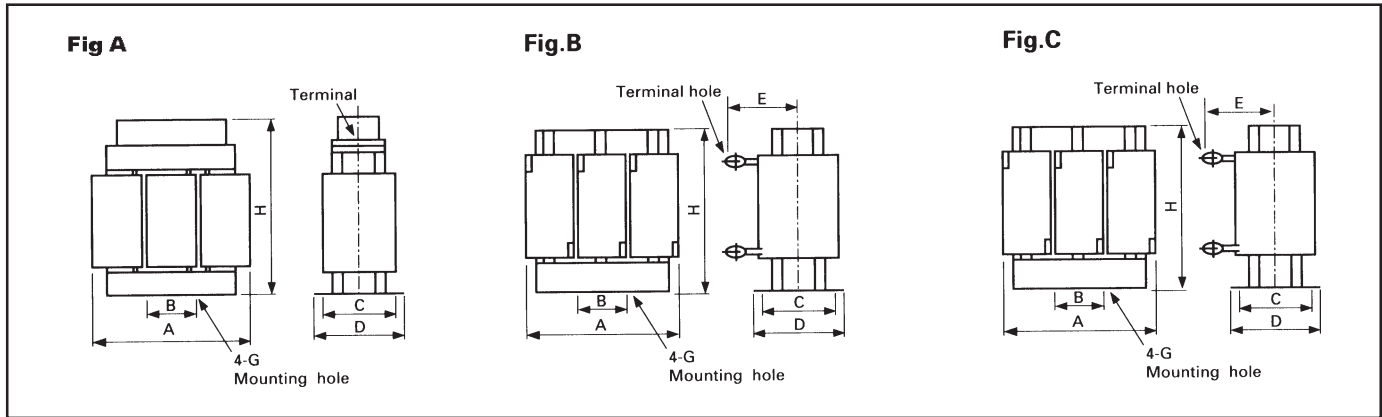

NOTE: Selected wire is supposed to be for three-phase.

Power supply voltage	ACR type	Fig.	Dimensions [inch(mm)]							Terminal size	Weight [lbs(kg)]							
			A	B	C	D	E	G	H									
Three-phase 230V	ACR2-0.4A	A	4.72(120)	1.57(40)	2.56(65)	3.54(90)	-	0.24x0.39 (6x10)	4.92(125)	M4	3.3(1.5)							
	ACR2-0.75A				2.95(75)	3.94(100)					5.5(2.5)							
	ACR2-1.5A											4.92(125)	3.54(90)	4.53(115)	6.8(3.1)			
	ACR2-2.2A				3.94(100)	4.92(125)					8.2(3.7)							
	ACR2-3.7A	B	7.09(180)	2.36(60)	3.35(85)	4.33(110)	3.54(90)	0.28x0.43 (7x11)	4.53(115)	M6	11(4.8)							
	ACR2-5.5A										7.48(190)	2.36(60)	3.54(90)	4.72(120)	6.69(170)	0.28x0.43(7x11)	7.48(190)	12(5.5)
	ACR2-7.5A																	7.87(200)
	ACR2-11A										11.22(285)	7.48(190)	4.72(120)	6.22(158)	7.48(190)	0.47x0.79(12x20)	8.27(210)	
	ACR2-15A	C	11.02(280)	5.91(150)	4.33(110)	5.43(138)	7.87(200)	0.39x0.79(10x20)	10.63(270)	0.51(13)	57(26)							
	ACR2-18.5A										11.02(280)	5.91(150)	4.33(110)	5.43(138)	7.87(200)	0.39x0.79(10x20)	10.63(270)	66(30)
	ACR2-22A	C	7.48(190)	2.36(60)	3.54(90)	4.72(120)	7.87(200)	0.28x0.39(7x10)	7.48(190)	0.51(13)	24(11)							
	ACR2-37										7.48(190)	2.36(60)	3.54(90)	4.72(120)	7.87(200)	0.28x0.39(7x10)	7.48(190)	26(12)
	ACR2-55	C	9.84(250)	3.94(100)	3.54(90)	4.72(120)	7.87(200)	0.35x0.55(9x14)	9.84(250)	0.51(13)	55(25)							
	ACR2-75										11.22(285)	7.48(190)	4.72(120)	6.22(158)	7.48(190)	0.47x0.79(12x20)	8.27(210)	57(26)
ACR2-90	C	11.02(280)	5.91(150)	4.33(110)	5.43(138)	7.87(200)	0.39x0.79(10x20)	10.63(270)	0.51(13)	66(30)								
ACR2-110										11.02(280)	5.91(150)	4.33(110)	5.43(138)	7.87(200)	0.39x0.79(10x20)	10.63(270)	66(30)	
Three-phase 460V	ACR4-0.75A	B	4.72(120)	1.57(40)	2.56(65)	3.54(90)	-	0.24x0.39 (6x10)	3.74(95)	M4	2.4(1.1)							
	ACR4-1.5A				2.95(75)	3.94(100)					4.2(1.9)							
	ACR4-2.2A											4.92(125)	3.54(90)	4.53(115)	6.8(3.1)			
	ACR4-3.7A				3.94(100)	4.53(115)					8.2(3.7)							
	ACR4-5.5A	B	7.09(180)	2.36(60)	3.35(85)	4.33(110)	3.54(90)	0.28x0.43 (7x11)	5.39(137)	M6	9.5(4.3)							
	ACR4-7.5A										7.48(190)	2.36(60)	3.35(85)	4.33(110)	6.69(170)	0.28x0.43(7x11)	5.39(137)	12(5.4)
	ACR4-11A																	7.87(200)
	ACR4-15A										11.22(285)	7.48(190)	4.72(120)	6.22(158)	7.48(190)	0.47x0.79(12x20)	8.27(210)	
	ACR4-18.5A	C	11.02(280)	5.91(150)	4.33(110)	5.43(138)	7.87(200)	0.39x0.79(10x20)	10.63(270)	0.51(13)	57(26)							
	ACR4-22A										11.02(280)	5.91(150)	4.33(110)	5.43(138)	7.87(200)	0.39x0.79(10x20)	10.63(270)	66(30)
	ACR4-37	C	7.48(190)	2.36(60)	3.54(90)	4.72(120)	7.87(200)	0.28x0.39(7x10)	7.48(190)	0.51(13)	24(11)							
	ACR4-55										7.48(190)	2.36(60)	3.54(90)	4.72(120)	7.87(200)	0.28x0.39(7x10)	7.48(190)	26(12)
	ACR4-75	C	9.84(250)	3.94(100)	3.54(90)	4.72(120)	7.87(200)	0.35x0.55(9x14)	9.84(250)	0.51(13)	55(25)							
	ACR4-110										11.22(285)	7.48(190)	4.72(120)	6.22(158)	7.48(190)	0.47x0.79(12x20)	8.27(210)	57(26)
ACR4-132	C	12.60(320)	4.72(120)	4.33(110)	5.91(150)	10.24(260)	0.47x0.79 (12x20)	11.81(300)	0.51(13)	88(40)								
ACR4-220										12.60(320)	4.72(120)	4.33(110)	5.91(150)	10.24(260)	0.47x0.79 (12x20)	11.81(300)	88(40)	
ACR4-280	C	14.96(380)	5.12(130)	4.33(110)	5.91(150)	10.24(260)	0.47x0.79 (12x20)	11.81(300)	0.51(13)	115(52)								

12. Ferrite Ring for Reducing Radio Noise (ACL)

13. Power Regenerative PWM Converter (RHC)

12. Ferrite Ring for Reducing Radio Noise (ACL)

■ The applicable wire size depends on the inner diameter and installation condition of the ferrite ring for reducing radio noise (ACL).

Table 3.18 Ferrite ring for reducing radio noise (ACL)

Ferrite ring type	Q'ty	No. of turns	Recommended wire size [mm ²]
ACL-40B	1	4	2.0, 3.5, 5.5
	2	2	8, 14
ACL-74B	1	4	8, 14
	2	2	22, 38, 60, 5.5 x 2, 8 x 2, 14 x 2, 22 x 2
	4	1	100, 150, 200, 250, 325, 38 x 2, 60 x 2, 100 x 2, 150 x 2

NOTE: Selected wire is supposed to be for three-phase.

13. Power Regenerative PWM Converter (RHC)

Combining the FRENIC5000G11S/P11S series inverter with the RHC series power regenerative PWM converter enables power regenerative braking to be easily performed. In this section, specifications, wiring diagram, standard capacity application list, dimensions, and optional parts are described.

The power regenerative PWM converter regenerates a large energy generated at the time of braking due to lifted and lowered load or large inertia centrifugal separator back to the AC power supply efficiently.

Features

- Raising the braking performance
- Energy-saving
- Space-saving
- Increasing the capacity by parallel wiring

■ Standard specifications

- 230V series

Type	RHC7.5-2A	RHC15-2A	RHC22-2A	RHC37-2A	RHC55-2A	
Applicable inverter capacity	7.5, 10	15, 20	25, 30	40, 50	60, 75	
Output ratings	Rated capacity [HP]	8.5	17	25.2	41	
	Rated voltage [V]	340				
	Rated current [A]	25	50	74	120	182
Input ratings	Overload capability	150% for 1min.				
	Phases, Voltage, Frequency	Three-phase 200-220V 50/60Hz				
	Voltage /frequency variations	Voltage: +10 to -15% (Voltage unbalance: 3% or less) Frequency: +5 to -5%				
	Required power supply capacity [kVA]	10	20	29	47	69
Regenerative braking	Cont. rating	100% of rated current, Continuous				
	Short-time rating	150% of rated current for 1min.				
Enclosure	IP40			IP00		
Cooling method	Forced fan cooling					
Weight [lbs(kg)]	26 (12.0)			62 (28.0)	97 (44.0)	

- 460V series

Type	RHC7.5-4A	RHC15-4A	RHC22-4A	RHC37-4A	RHC55-4A	RHC75-4A	RHC110-4A	RHC160-4A	RHC220-4A	
Applicable inverter capacity	7.5, 10	15, 20	25, 30	40, 50	60, 75	100	125, 150	200, 250	300, 350	
Output ratings	Rated capacity [HP]	8.8	17	25.2	41	62	83	124	181	
	Rated voltage [V]	680								
	Rated current [A]	13	25	37	60	91	122	182	266	366
Input ratings	Overload capability	150% for 1min.								
	Phases, Voltage, Frequency	Three-phase 400-440V 50/60Hz *1)								
	Voltage /frequency variations	Voltage: +10 to -15% (Voltage unbalance: 3% or less) Frequency: +5 to -5%								
	Required power supply capacity [kVA]	10	20	29	47	69	97	144	211	291
Regenerative braking	Cont. rating	100% of rated current, Continuous								
	Short-time rating	150% of rated current for 1min.								
Enclosure	IP40			IP00						
Cooling method	Forced fan cooling									
Weight [lbs(kg)]	26 (12.0)			62 (28.0)	73 (33.0)	132 (60.0)	187 (85.0)	265 (120.0)	386 (175.0)	

*1) If 380V is applied, the rated capacity reduces.

Chapter 3

13. Power Regenerative PWM Converter (RHC)

■ Common specifications

Control	Control method	Sinusoidal wave input current control
	Operation method	Operation starts at power-on after wiring completed Input signal: Run command, Stop command, Reset input
	Operation status signal	Ready to operate
	Input power-factor	0.95 or higher (at 100% load)
	Input harmonic current	Conversion coefficient $K_i=0$ (based on "Guideline for Harmonic Current Suppression" by MITI "Ministry of International Trade and Industry")
	Restart after momentary power failure	Automatically restarts the converter at power recovery
	Current limiting control	Controls current under the preset current limiting level.
Indication	Running, stopping	Input current, Input voltage, Input power, Output voltage (by 7-segment LED display)
	Program mode	Displays function codes and data
	Trip mode	Displays cause of the trip by code (by 7-segment LED display). LD1 (LED) is on when CPU error occurs.
Protection	Overcurrent	Detects AC overcurrent to stop the operation of the unit. (OC)
	Overvoltage	Detects DC overvoltage to stop the operation of the unit. (OV)
	Overload	Stops operation of the unit by electronic thermal function and detection of temperature inside (OL)
	Overheating	Stops operation of the unit by detecting heat sink overheating. (OH)
	AC fuse blown	Stops operation of the unit by detecting AC fuse blown. (AFUS) *1)
	DC fuse blown	Stops operation of the unit by detecting DC fuse blown. (DFUS) *1)
	Abnormal frequency	Stops operation of the unit by detecting frequency of AC input power at power-on. (FRE)
	DC link circuit undervoltage	Stops operation of the unit when the DC voltage drops below the undervoltage level (165V or less in 230V seires, 365V or less in 460V seires). (Auto-reset is selectable by function setting.) (LU)
AC circuit undervoltage	Stops operation of the unit when the AC voltage drops below the undervoltage level (165V or less in 230V seires, 365V or less in 460V seires). (Auto-reset only, No alarm indication)	
Condition (Installation and operation)	Installation location	Indoor use only. Altitude: 3300ft (1000m) or less. Free from corrosive gases, flammable gases, dusts, and direct sunlight.
	Ambient temperature	-20 to +50°C (-4 to 122°F)
	Ambient humidity	20 to 90%RH (non-condensing)
	Vibration	5.9m/s ² or less
Storage condition		-20 to +65°C (-4 to 149°F)

*1) Not provided with RHC22-□ or smaller model.

13. Power Regenerative PWM Converter (RHC)

Terminal function

	Symbol	Terminal name	Function	
Main circuit	R,S,T	Power input	Connect a 3-phase power supply via an exclusive reactor.	
	P(+),N(-)	Converter output	Connect the power input terminals P(+), N(-) of inverter.	
	E(G)	Grounding	Grounding terminal for converter chassis (housing).	
	R0,T0	Auxiliary control power supply	Connect the same AC power supply as that of the main circuit to back up the control circuit power supply.	50HP or larger model only
	U1,U2	Auxiliary power supply	Connect the power supply transformer used for cooling fans and magnetic contactor for charging resistor by - pass. Change of wiring inside the converter is necessary when the main circuit voltage is 380V.	50HP or larger model in 460V series only
Voltage detection	R1,S1,T1	Synchronous power input	Used for detecting for converter control. Connect to the power supply side of exclusive reactor and exclusive filter	
Control input	RUN	Operation command	RUN-CM: ON - The converter runs; OFF - The converter stops.	
	RST	Alarm reset	When RST-CM is on after the cause of trip is removed during alarm stop, the active protective function (converter is in trip state) is reset and the converter restarts operation.	
	X1	Function extension	Not in use at normal use	
	CM	Common for input signal	Common terminal for contact input signal.	
Analog I/O	AI	Function extension	Not in use at normal use	
	AO	Function extension	Not in use at normal use	
	M	Analog I/O common	Common terminal for analog I/O signal.	
Transistor output	Y1	Overload early warning	Outputs overload early warning ON signal before overload protective function is activated. (Warning level can be preset by Function F07.)	Allowable output of transistor: 27V DC, 50mA max.
	Y2	Overcurrent early warning	Outputs ON signal when load level (F08 x F10, or F09 x F10) is 100 or over. (For F08, F09, F10, see next page)	
	CME	Common (transistor output)	Common for transistor output signal.	
Relay output	RYA,RYC	Ready output	Outputs ON signal when the converter is ready for operation. (Initial charge and voltage step-up completed)	
	30A,30B,30C	Alarm relay output	Outputs a contact signal when a protective function is activated and converter stops by an alarm. (1SPDT contact, 30A-30C: ON - At trip mode)	Contact rating: 250V AC, 0.3A (cos ϕ =0.3)

Basic wiring diagram

The following diagram is one of the simplest operation sequence using PWM converter.

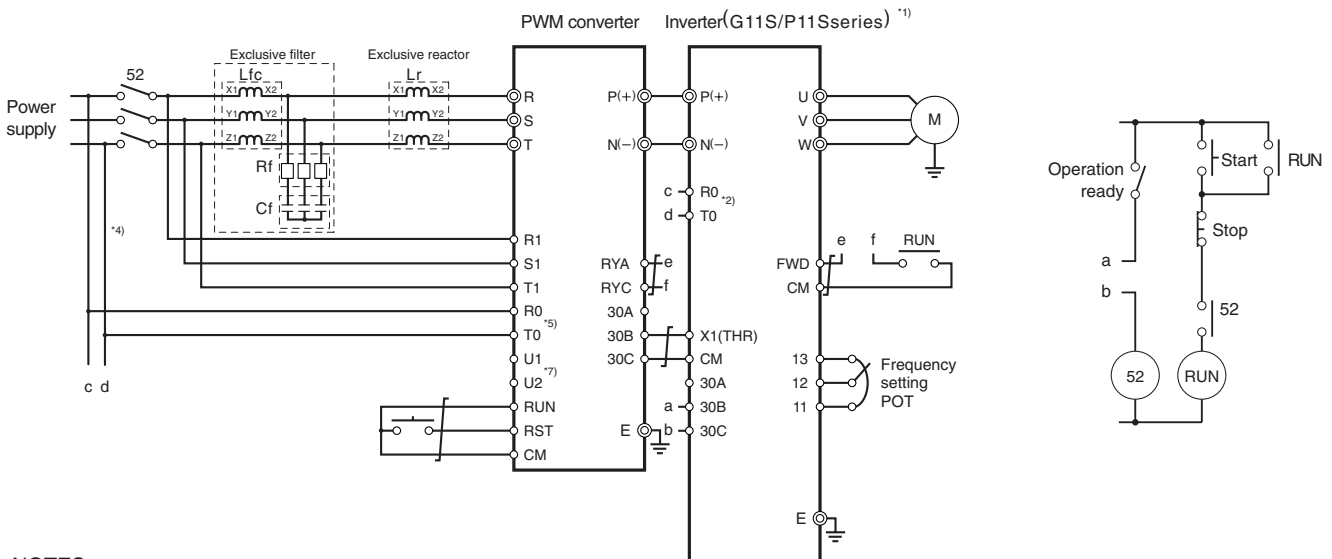

NOTES:

- Design the sequence so that inverter operation command can be input after PWM converter is ready to operate.
- *1) For the applicable inverter models, refer to the combination table on page 3-26.
- *2) The power supply for cooling fans and magnetic contactors inside inverter may be required. (When a converter has to be connected to an inverter of 40HP or larger, change-over the connector CNRXTX in the inverter.
- *3) When the actual power supply capacity is insufficient compared to the required capacity, the PWM converter may be damaged.
- *4) An insulation transformer may be necessary for some models. For details, see the instruction manual.
- *5) Provided with 50HP model or larger.
- *6) Be sure to connect the exclusive filter to the primary side (power supply side) of the exclusive reactor.
- *7) When the main circuit voltage is 380V, connection inside the converter has to be changed.

Chapter 3

13. Power Regenerative PWM Converter (RHC)

■ Function setting

	Function		Setting range	Min. unit	Factory setting
	Code	Name			
Operation monitor	F00	DC link circuit voltage	Detection level	1V	-
	F01	Input voltage		1V	-
	F02	Input current		1A	-
	F03	Input power		1kW	-
Basic functions	F04	LED monitor selection	0: F00 DC link circuit voltage 1: F01 Input voltage 2: F02 Input current 3: F03 Input power	-	0
	F05	LV cancel	0: Active 1: Inactive	-	0
	F06	Filter capacitor	0: Connect 1: Disconnect	-	1
	F07	Overload early warning level	50 to 105%	1%	80%
	F08	Input current limiter (Driving)	0 to 150%	1%	150%
	F09	Input current limiter (Braking)	-150 to 0%	1%	-150%
Alarm monitor	F10	Current limiter output (Ratio)	50 to 100%	1%	100%
	E00	Alarm data (Latest)	Alarm code	-	-
	E01	Alarm data (the last)		-	-
	E02	Alarm data (the last but one)		-	-
	E03	Alarm data (the last but two)		-	-
	E04	Alarm history clear	0: Inactive 1: Active	-	0

■ Protective functions

Function	Description	LED monitor
Overcurrent	Stops the converter operation immediately when the converter input current reaches overcurrent protection level.	OC
DC undervoltage	- Stops the converter operation immediately when the main circuit DC voltage drops below undervoltage level, and retains the trip state. - The trip state is automatically reset when the power failure time becomes long and the control circuit cannot be held.	LU
AC undervoltage	- Stops the converter operation immediately when the power supply voltage drops below undervoltage level. - The trip state is automatically reset when the power failure time becomes long and the control circuit power cannot be held.	
Overvoltage	Stops the converter operation immediately when the main circuit DC voltage reaches overvoltage protection level.	OU
Overload	Stops the converter operation immediately when the load connected to the converter becomes excessive.	OL
Converter overheating	Stops the converter operation immediately when it detects excess heat sink temperature or an abnormal rise in temperature inside the converter.	OH
Power supply abnormal frequency	Stops the converter operation immediately when the power supply exceeds the frequency range of $50 \pm 4\text{Hz}$ or $60 \pm 4\text{Hz}$. (Detected only when power-on)	FrE
NVRAM fault	Stops the converter operation immediately when nonvolatile memory on the control PC board in the converter is faulty.	Err1
CPU error	Stops the converter operation immediately when it detects CPU error on the PC board in the converter.	LD1 on

NOTE:

When the control power voltage is reduced until the operation of converter control circuit cannot be maintained, all the protective functions are automatically reset.

13. Power Regenerative PWM Converter (RHC)

Table 3.23 Combination of inverter and converter

Power supply voltage	Inverter type		PWM converter main unit type	Exclusive reactor type	Exclusive filter			
	G11S series	P11S series			Filter (Reactor type)	Filter (Capacitor type)	Filter (Resistor type)	
Three-phase 230V	FRN007G11S-2UX	FRN007P11S-2UX	RHC7.5-2A	LR2-7.5	LFC2-7.5	CF2-7.5	RF2-7.5	
	FRN010G11S-2UX	FRN010P11S-2UX						
	FRN015G11S-2UX	FRN015P11S-2UX	RHC15-2A	LR2-15	LFC2-15	CF2-15	RF2-15	
	FRN020G11S-2UX	FRN020P11S-2UX						
	FRN025G11S-2UX	FRN025P11S-2UX	RHC22-2A	LR2-22	LFC2-22	CF2-22	RF2-22	
	FRN030G11S-2UX	FRN030P11S-2UX						
	FRN040G11S-2UX	FRN040P11S-2UX	RHC37-2A	LR2-37L	LFC2-37	CF2-37	GRZG400-1Ω	
	FRN050G11S-2UX	FRN050P11S-2UX						
	FRN060G11S-2UX	FRN060P11S-2UX	RHC55-2A	LR2-55L	LFC2-55	CF2-55	GRZG400-0.6Ω	
	FRN075G11S-2UX	FRN075P11S-2UX						
	FRN100G11S-2UX	FRN100P11S-2UX	Contact Fuji					
	FRN125G11S-2UX	FRN125P11S-2UX						
	-	FRN150P11S-2UX						
Three-phase 460V	FRN007G11S-4UX	FRN007P11S-4UX	RHC7.5-4A	LR4-7.5	LFC4-7.5	CF4-7.5	RF4-7.5	
	FRN010G11S-4UX	FRN010P11S-4UX						
	FRN015G11S-4UX	FRN015P11S-4UX	RHC15-4A	LR4-15	LFC4-15	CF4-15	RF4-15	
	FRN020G11S-4UX	FRN020P11S-4UX						
	FRN025G11S-4UX	FRN025P11S-4UX	RHC22-4A	LR4-22	LFC4-22	CF4-22	RF4-22	
	FRN030G11S-4UX	FRN030P11S-4UX						
	FRN040G11S-4UX	FRN040P11S-4UX	RHC37-4A	LR4-37L	LFC4-37	CF4-37	GRZG400-4Ω	
	FRN050G11S-4UX	FRN050P11S-4UX						
	FRN060G11S-4UX	FRN060P11S-4UX	RHC55-4A	LR4-55L	LFC4-55	CF4-55	GRZG400-2.4Ω	
	FRN075G11S-4UX	FRN075P11S-4UX						
	FRN100G11S-4UX	FRN100P11S-4UX	RHC75-4A	LR4-75L	LFC4-75	CF4-75	RF4-75	
	FRN125G11S-4UX	FRN125P11S-4UX	RHC7.5-4A	LR4-110L	LFC4-110	CF4-110	RF4-110	
	FRN150G11S-4UX	FRN150P11S-4UX						
	FRN200G11S-4UX	FRN200P11S-4UX	RHC160-4A	LR4-160L	LFC4-160	CF4-160	RF4-160	
	FRN250G11S-4UX	FRN250P11S-4UX						
	FRN300G11S-4UX	FRN300P11S-4UX	RHC220-4A	LR4-220L	LFC4-220	CF4-220	RF4-220	
	FRN350G11S-4UX	FRN350P11S-4UX						
	FRN400G11S-4UX	FRN400P11S-4UX	Contact Fuji					
FRN450G11S-4UX	FRN450P11S-4UX							
FRN500G11S-4UX	FRN500P11S-4UX							
FRN600G11S-4UX	FRN600P11S-4UX							
	-	FRN700P11S-4UX						
		FRN800P11S-4UX						

NOTES: • When using an exclusive filter, use a reactor type filter, a capacitor type one, and resistor type one at the same time.
• More than one inverters can be connected to one converter if the converter capacity is not exceeded.

Chapter 3

13. Power Regenerative PWM Converter (RHC)

■ Dimensions

• PWM converter main unit

• 30HP or smaller

• 40 to 250HP

• 300HP or larger

unit: inch (mm)

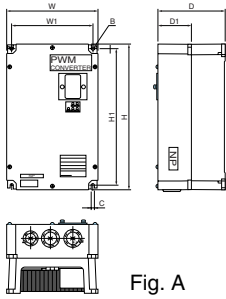

Fig. A

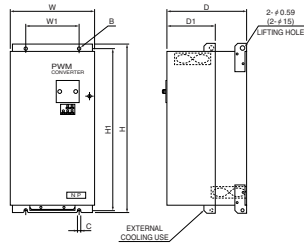

Fig. B

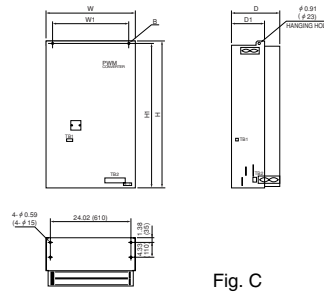

Fig. C

Power supply voltage	PWM converter main unit type	Fig.No	Dimensions [inch(mm)]								Weight [lbs(kg)]
			W	W1	H	H1	D	D1	B	C	
Three-phase 230V	RHC7.5-2A	A	10.04	8.90	15.79	14.88	7.44	3.68	ø0.39 (ø10)	0.39 (10)	26(12)
	RHC15-2A		(255)	(226)	(401)	(378)	(189)	(93.5)			
	RHC22-2A										
	RHC37-2A	B	11.02(280)	7.09(180)	24.21(615)	23.43(595)	10.83(275)	6.69(170)			62(28)
	RHC55-2A		13.39(340)	9.45(240)	29.53(750)	28.74(730)	11.02(280)	6.50(165)			97(44)
Three-phase 460V	RHC7.5-4A	A	10.04	8.90	15.79	14.88	7.44	3.68	ø0.39 (ø10)	0.39 (10)	26(12)
	RHC15-4A		(255)	(226)	(401)	(378)	(189)	(93.5)			
	RHC22-4A										
	RHC37-4A	B	11.02	7.09	21.65(550)	20.87(530)	10.43(265)	6.30(160)			57(26)
	RHC55-4A		(280)	(180)	26.57(675)	25.79(655)	10.83(275)	6.69(170)			73(33)
	RHC75-4A	C	20.87	16.93	33.07	31.89	10.63(270)	5.91(150)	ø0.59 (ø15)	0.59 (15)	132(60)
	RHC110-4A		(530)	(430)	(840)	(810)	12.40(315)	7.48(190)			187(85)
	RHC160-4A				43.31	42.13(1070)	14.17	8.66(220)			265(120)
RHC220-4A	C	26.77(680)	22.83(580)	(1100)	42.52(1080)	(360)	9.65(245)			386(175)	

13. Power Regenerative PWM Converter (RHC)

- RHC series exclusive reactor
- 30HP or smaller

Power supply voltage	Exclusive reactor type	Dimensions [inch(mm)]								Weight [lbs(kg)]
		W	W1	W2	H	H1	D	D1	C	
230V	LR2-7.5	8.27(210)	6.69(170)	4.72(120)	5.91(150)	4.72(120)	5.75(146)	4.57(116)	0.25(6.4)	40(18)
	LR2-15				7.48(190)	5.51(140)	6.54(166)	5.35(136)	0.33(8.4)	57(26)
	LR2-22	10.63(270)	8.66(220)		8.27(210)	4.72(120)	6.93(176)			88(40)
460V	LR4-7.5	8.27(210)	6.69(170)	4.72(120)	5.91(150)	3.94(100)	5.75(146)	4.57(116)	0.21(5.4)	40(18)
	LR4-15				7.48(190)	4.72(120)	6.54(166)	5.35(136)	0.25(6.4)	57(26)
	LR4-22	10.63(270)	8.66(220)		8.27(210)		6.89(175)			88(40)

- 40HP or larger

Power supply voltage	Exclusive reactor type	Dimensions [inch(mm)]									Weight [lbs(kg)]
		W	W1	H	D	D1	D2	B	C		
230V	LR2-37L	11.81(300)	7.87(200)	10.83(275)	5.35(136)	4.33(110)	6.50(165)	0.35(9)	0.33(8.4)	77(35)	
	LR2-55L	12.99(330)	8.66(220)	12.80(325)	6.38(162)	4.72(120)	6.69(170)		0.41(10.5)	108(49)	
	LR4-37L	11.81(300)	7.87(200)	10.83(275)	5.35(136)	4.33(110)	5.91(150)		0.25(6.4)	77(35)	
460V	LR4-55L	12.99(330)	8.66(220)	12.80(325)	6.38(162)	4.72(120)	6.50(165)	0.33(8.4)	108(49)		
	LR4-75L	13.78(350)	4.33(110)	15.35(390)	10.04(255)	8.46(215)	6.69(170)	0.47(12)	0.41(10.5)	143(65)	
	LR4-110L	13.39(340)		15.94(405)	10.83(275)	9.25(235)	7.28(185)	0.59(15)		187(85)	
	LR4-160L	15.35(390)	5.12(130)	18.11(460)	11.81(300)	10.24(260)	8.46(215)		0.51(13.0)	254(115)	
	LR4-220L			19.29(490)	12.60(320)	10.83(275)	8.86(225)			320(145)	

- RHC series exclusive filter
- Filter (Reactor type)

Power supply voltage	Filter (Reactor type)	Dimensions [inch(mm)]								Weight [lbs(kg)]
		W	W1	W2	H	H1	D	D1	C	
230V	LFC2-7.5	6.69(170)	5.31(135)	3.54(90)	4.72(120)	4.72(120)	3.98(101)	2.99(76)	0.25(6.4)	177(5)
	LFC2-15				5.51(140)	5.51(140)	4.76(121)	3.78(96)	0.33(8.4)	241(11)
	LFC2-22	7.09(180)	5.91(150)		6.50(165)	4.72(120)	4.17(106)	4.17(106)		291(13)
460V	LFC4-7.5	6.69(170)	5.31(135)		4.72(120)	3.15(80)	3.98(101)	2.99(76)	0.21(5.3)	177(5)
	LFC4-15				5.51(140)	3.94(100)	4.76(121)	3.78(96)	0.25(6.4)	241(11)
	LFC4-22	7.09(180)	5.91(150)		6.50(165)	4.33(110)	5.35(136)	4.17(106)		291(13)

- 40HP or larger

Power supply voltage	Filter (Reactor type)	Dimensions [inch(mm)]								Weight [lbs(kg)]
		W	W1	H	D	D1	D2	B	C	
230V	LFC2-37	10.04(255)	6.69(170)	7.68(195)	4.76(121)	3.74(95)	5.71(145)	0.28(7)	0.33(8.4)	42(19)
	LFC2-55				5.16(131)	4.13(105)	6.30(160)		0.41(10.5)	49(22)
	LFC4-37	10.04(255)	6.69(170)	7.68(195)	4.76(121)	3.74(95)	5.31(135)	0.28(7)	0.25(6.4)	40(18)
460V	LFC4-55				5.16(131)	4.13(105)	5.91(150)		0.33(8.4)	46(21)
	LFC4-75	12.60(320)	4.13(105)	11.61(295)	8.27(210)	6.69(170)				66(30)
	LFC4-110			12.60(320)	8.66(220)	6.69(170)				77(35)
	LFC4-160	13.78(350)	4.33(110)	14.57(370)	8.66(220)	7.48(190)	6.30(160)	0.47(12)	0.41(10.5)	119(55)
	LFC4-220	14.57(370)	4.72(120)	15.35(390)	9.65(245)	8.46(215)	7.87(200)		0.51(13.0)	154(70)

- Filter (Capacitor type)

Power supply voltage	Filter (Capacitor type)	Dimensions [inch(mm)]							Weight [lbs(kg)]
		W	W1	W2	H	H1	D	D1	
230V	CF2-7.5	6.50(165)	5.91(150)	5.12(130)	5.31(135)	3.94(100)	2.76(70)	1.57(40)	2.9(1.3)
	CF2-15				7.28(185)	5.91(150)			4.2(1.9)
	CF2-22				8.46(215)	7.09(180)			5.1(2.3)
	CF2-35				7.28(185)	5.91(150)			5.5(2.5)
	CF2-55				8.07(205)	7.48(190)			6.81(173)
460V	CF4-7.5	6.50(165)	5.91(150)	5.12(130)	4.53(115)	3.15(80)			2.2(1.0)
	CF4-15				5.31(135)	3.94(100)			2.9(1.3)
	CF4-22				6.10(155)	4.72(120)			3.3(1.5)
	CF4-37				7.28(185)	5.91(150)	4.2(1.9)		4.2(1.9)
	CF4-55				7.28(185)	5.91(150)	5.1(2.3)		5.1(2.3)
	CF4-75	8.07(205)	7.48(190)	6.81(173)	8.07(205)	6.69(170)	6.4(2.9)		6.4(2.9)
	CF4-110				9.65(245)	8.27(210)	8.8(4.0)		8.8(4.0)
	CF4-160	11.02(280)	10.43(265)	9.45(240)	9.06(230)	7.09(180)	3.54(90)	2.17(55)	12.1(5.5)
	CF4-220				11.02(280)	9.06(230)			15.4(7.0)

- Filter (Resistor type)

Power supply voltage	Filter (Resistor type)	Dimensions [inch(mm)]							Weight [lbs(kg)]
		W	W1	H	H1	H2	D	D1	
230V	RF2-7.5	7.87(200)	6.31(160)	11.42(290)	10.87(276)	9.25(235)	3.94(100)	3.27(83)	7.9(3.6)
	RF2-15			16.14(410)	15.59(396)	13.98(355)			13(6.0)
	RF2-22	9.84(250)		15.55(395)	15.00(381)	13.39(340)			3.74(95)
460V	RF4-7.5	7.87(200)		11.42(290)	10.87(276)	9.25(235)		3.27(83)	7.9(3.6)
	RF4-15			16.14(410)	15.59(396)	13.98(355)			13(6.0)
	RF4-22	9.84(250)		15.55(395)	15.00(381)	13.39(340)			3.74(95)

- 50HP, 75HP

Power supply voltage	Filter (Resistor type)	Weight [lbs(kg)]	Dimensions [inch(mm)]		
			W	W1	H
230V	GRZG400-1Ω	1.9(0.85)	15.15(384)	16.14(410)	15.15(384)
460V	GRZG400-0.6Ω				
460V	GRZG400-4.0Ω				
460V	GRZG400-2.4Ω				

- 100HP or larger

Power supply voltage	Filter (Resistor type)	Weight [lbs(kg)]	Dimensions [inch(mm)]		
			W	W1	H
460V	RF4-75	44(20)	20.67(525)	21.85(555)	18.5(470)
460V	RF4-110	44(20)			
460V	RF4-160	51(23)			
460V	RF4-220	55(25)			

