

8. Maintenance and Inspection

Proceed with daily inspection and periodic inspection to prevent malfunction and ensure long-term reliability. Note the following:

8-1 Daily Inspection

During operation, a visual inspection for abnormal operation is completed externally without removing the covers

The inspections usually cover the following:

- (1) The performance (satisfying the standard specification) is as expected.
- (2) The environment satisfies standard specifications.
- (3) The keypad panel display is normal.
- (4) There are no abnormal sounds, vibrations, or odors.
- (5) There are no indications of overheating or no discoloration.

8-2 Periodical Inspection

Periodic inspections must be completed after stopping operations, cutting off the power source, and removing the surface cover.

Note that after turning off the power, the smoothing capacitors in the DC section in the main circuit take time to discharge. To prevent electric shock, confirm using a multimeter that the voltage has dropped below the safety value (25 V DC or below) after the charge lamp (CRG) goes off.

 WARNING	<ul style="list-style-type: none"> • Start the inspection at least five minutes after turning off the power supply for inverter rated at 30HP or less, and ten minutes for inverter rated at 40HP or more. (Check that the charge lamp (CRG) goes off, and that the voltage is 25V DC or less between terminals P(+) and N(-). Electric shock may result. • Only authorized personnel should perform maintenance and component replacement operations. (Remove metal jewelry such as watches and rings.) (Use insulated tools.) • Never modify the inverter. Electric shock or injury may result.
--	--

Table 8-2-1 Periodical inspection list

Check parts	Check items	How to inspect	Evaluation Criteria	
Environment	<ol style="list-style-type: none"> 1) Check the ambient temperature, humidity, vibration, atmosphere (dust, gas, oil mist, water drops). 2) Is the area surrounding the equipment clear of foreign objects. 	<ol style="list-style-type: none"> 1) Conduct visual inspection and use the meter. 2) Visual inspection 	<ol style="list-style-type: none"> 1) The specified standard value must be satisfied. 2) The area is clear. 	
Keypad panel	<ol style="list-style-type: none"> 1) Is the display hard to read? 2) Are the characters complete? 	1),2) Visual inspection	1),2) The display can be read and is not abnormal.	
Structure such as a frame or cover	<ol style="list-style-type: none"> 1) Is there abnormal sound or vibration? 2) Are nuts or bolts loose? 3) Is there deformation or damage? 4) Is there discoloration as a result of overheating? 5) Are there stains or dust? 	<ol style="list-style-type: none"> 1) Visual and aural inspection 2) Tighten. 3),4),5) Visual inspection 	1), 2), 3), 4), 5) Not abnormal	
Main circuit	Common	<ol style="list-style-type: none"> 1) Are there loose or missing nuts or bolts? 2) Are there deformation, cracks, damage, and discoloration due to overheating or deterioration in the equipment and insulation? 3) Are there stains and dust? 	<ol style="list-style-type: none"> 1) Tighten. 2),3) Visual inspection 	1), 2), 3) Not abnormal Note: Discoloration of the bus bar does not indicate a problem.
	Conductor and wire	<ol style="list-style-type: none"> 1) Is there discoloration or distortion of a conductor due to overheating? 2) Are there cracks, crazing or discoloration of the cable sheath? 	1),2) Visual inspection	1), 2) Not abnormal

Main circuit	Terminal block	Is there damage?	Visual inspection	Not abnormal
	Smoothing capacitor	1) Is there electrolyte leakage, discoloration, crazing, or swelling of the case? 2) Is the safety valve not protruding or are valves protruding too far? 3) Measure the capacitance if necessary.	1), 2) Visual inspection 3) * Estimate life expectancy from maintenance information and from measurements using capacitance measuring equipment.	1), 2) Not abnormal 3) Capacitance \geq initial value x 0.85
Main circuit	Resistor	1) Is there unusual odor or damage to the insulation by overheating? 2) Is there an open circuit?	1) Visual and olfactory inspection 2) Conduct a visual inspection or use a multimeter by removing the connection on one side.	1) Not abnormal 2) Less than about $\pm 10\%$ of the indicated resistance value
	Transformer and reactor	Is there abnormal buzzing or an unpleasant smell?	Aural, olfactory, and visual inspection	Not abnormal
	Magnetic conductor and relay	1) Is there rattling during operation? 2) Are the contacts rough?	1) Aural inspection 2) Visual inspection	1),2)Not abnormal
Control circuit	Control PC board and connector	1) Are there any loose screws or connectors? 2) Is there an unusual odor or discoloration? 3) Are there cracks, damage, deformation, or excessive rust? 4) Is there electrolyte leakage or damage to the capacitor?	1) Tighten. 2) Visual and olfactory inspection 3) Visual inspection 4) * Estimate life expectancy by visual inspection and maintenance information	1),2),3),4)Not abnormal
Cooling system	Cooling fan	1) Is there abnormal sound or vibration? 2) Are nuts or bolts loose? 3) Is there discoloration due to overheating?	1)Aural and visual inspection. Turn manually (confirm the power is off). 2) Tighten. 3) Visual inspection 4) * Estimate life expectancy by maintenance information	1) The fan must rotate smoothly. 2), 3) Not abnormal
	Ventilation	Is there foreign matter on the heat sink or intake and exhaust ports?	Visual inspection	Not abnormal

Note: If equipment is stained, wipe with a clean cloth. Vacuum the dust.

***Estimation of life expectancy based on maintenance information**

The maintenance information is stored in the inverter keypad panel and indicates the electrostatic capacitance of the main circuit capacitors and the life expectancy of the electrolytic capacitors on the control PC board and of the cooling fans. Use this data as the basis to estimate the life expectancy of parts.

1) Determination of the capacitance of the main circuit capacitors

This inverter is equipped with a function to automatically indicate the capacitance of the capacitors installed in the main circuit when powering up the inverter again after disconnecting the power according to the prescribed conditions.

The initial capacitance values are set in the inverter when shipped from the factory, and the decrease ratio (%) to those values can be displayed.

Use this function as follows:

- (1) Remove any optional cards from the inverter. Also disconnect the DC bus connections to the main circuit P(+) and N(-) terminals from the braking unit or other inverters if connected. The existing power-factor correcting reactor (DC reactor) need not be disconnected. A power supply introduced to the auxiliary input terminals (R0, T0) that provides control power should be isolated.
- (2) Disable all the digital inputs (FWD, REV, X1-X9) on the control terminals. Also disconnect RS-485 communication if used. Turn on the main power supply. Confirm that the cooling fan is rotating and that the inverter is not operating. (There is no problem if the "OH2 External thermal relay tripped" trip function is activated due to the digital input terminal setting off.)
- (3) Turn the main power off.
- (4) Turn on the main power again after verifying that the charge lamp is completely off.
- (5) Open the maintenance information on the keypad panel and confirm the capacitance values of the built-in capacitors.

2) Life expectancy of the control PC board

The actual capacitance of a capacitor is not measured in this case. However, the integrated operating hours of the control power supply multiplied by the life expectancy coefficient defined by the temperature inside the inverter will be displayed. Hence, the hours displayed may not agree with the actual operating hours depending on the operational environment.

Since the integrated hours are counted by unit hours, power input for less than one hour will be disregarded.

3) Life expectancy of cooling fan

The integrated operating hours of the cooling fan are displayed. Since the integrated hours are counted by unit hours, power input for less than one hour will be disregarded.

The displayed value should be considered as a rough estimate because the actual life of a cooling fan is influenced significantly by the temperature.

Table 8-2-2 Rough estimate of life expectancy using maintenance information

Parts	Level of judgment
Capacitor in main circuit	85% or less of the initial value
Electrolytic capacitor on control PC board	61,000 hours
Cooling fan	40,000 hours (5HP or less), 25,000 hours (Over 7.5HP) (*1)

*1 Estimated life expectancy of a ventilation-fan at inverter ambient temperature of 40°C (104°F)

8-3 Measurement of Main Circuit Electrical Quantity

The indicated values depend on the type of meter because the harmonic component is included in the voltage and current of the main circuit power (input) and the output (motor) side of the inverter. When measuring with a meter for commercial power frequency use, use the meters shown in Table 8.3.1.

The power-factor cannot be measured using power-factor meters currently available on the market, which measure the phase difference between voltage and current. When power-factors must be measured, measure the power, voltage, and current on the input side and output side, then calculate the power-factor using the following formula:

$$\text{Power factor} = \frac{\text{Power}[W]}{\sqrt{3} \times \text{Voltage}[V] \times \text{Current}[A]} \times 100[\%]$$

Table 8-3-1 Meters for measuring main circuit

Item	Input (power supply) side			Output (motor) side			DC link circuit voltage (P(+)-N(-))
	Voltage	Current*		Voltage	Current		
Meter name	Ammeter A _{R,S,T}	Voltmeter V _{R,S,T}	Powermeter W _{R,S,T}	Ammeter A _{U,V,W}	Voltmeter V _{U,V,W}	Powermeter W _{U,V,W}	DC voltmeter V
Meter type	Moving-iron type	Rectifier or moving-iron type	Digital power meter	Moving-iron type	Rectifier type	Digital power meter	Moving-coil type
Symbol							

Note: When measuring the output voltage using a rectifier type meter, an error may occur. Use a digital AC power meter to ensure accuracy.

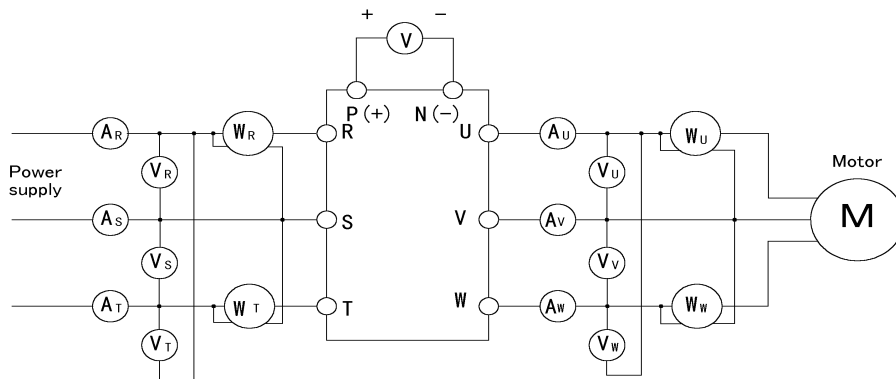

Fig 8-3-1 Connection of the meters

8-4 Insulation Test

Avoid testing an inverter with a megger because an insulation test is completed at the factory. If a megger test must be completed, proceed as described below. Use of an incorrect testing method may result in product damage.

If the specifications for the dielectric strength test are not followed, the inverter may be damaged. If a dielectric strength test must be completed, contact your local distributor or nearest Fuji Electric sales office.

(1) Megger test for the main circuit

- ① Use a 500V DC type megger and isolate the main power before commencing measurement.
- ② If the test voltage is connected to the control circuit, remove all connection cables to the control circuit.
- ③ Connect the main circuit terminals using common cables as shown in Fig. 8-4-1.
- ④ Execute the megger test only between the common cables connected to the main circuit and the ground (terminal \ominus G).
- ⑤ A megger indicating $5M\Omega$ or more is normal. (This is the value measured with an inverter only.)

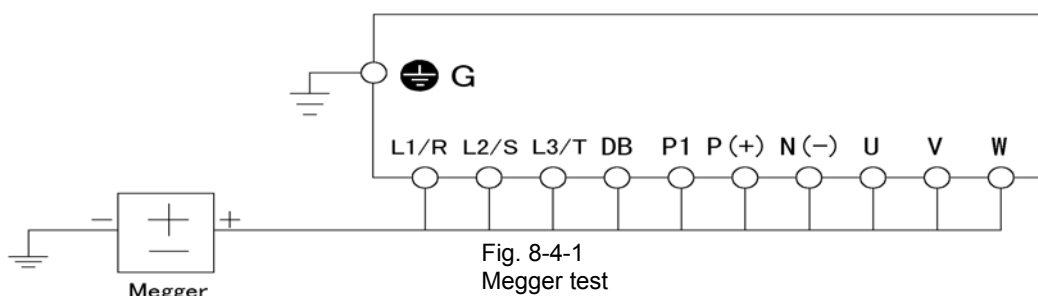

(2) Insulation test in the control circuit

A megger test and a dielectric strength test must not be performed in the control circuit. Prepare a high resistance range multimeter for the control circuit.

- ① Remove all external cables from the control circuit terminals.
- ② Conduct a continuity test between grounds. A result of $1M\Omega$ or more is normal.

(3) Exterior main circuit and sequence control circuit

Remove all cables from inverter terminals to ensure the test voltage is not applied to the inverter.

8-5 Parts Replacement

The life expectancy of a part depends on the type of part, the environment, and usage conditions. Parts should be replaced as shown in Table 8-5-1.

Table 8-5-1 Part replacement

Part name	Standard period for replacement	Comments
Cooling fan	3 years	Exchange for a new part.
Smoothing capacitor	5 years	Exchange for a new part (determine after checking).
Electrolytic capacitor on the PC board	7 years	Exchange for a new PC board (determine after checking).
Fuse	10 years	Exchange for a new part.
Other parts	—	Determine after checking.

8-6 Inquiries about Products and Product Guarantee

(1) Inquiries

If there is damage, a fault in the product, or questions concerning the product, contact your local distributor or nearest Fuji Electric sales office:

- a) Inverter type
- b) Serial No. (equipment serial number)
- c) Purchase date
- d) Inquiry details (e.g., damaged part, extent of damage, questions, status of fault)

(2) **Product guarantee --- Please take the following items into consideration when placing your order.**

When requesting an estimate and placing your orders for the products included in these materials, please be aware that any items such as specifications which are not specifically mentioned in the contract, catalog, specifications or other materials will be as mentioned below.

In addition, the products included in these materials are limited in the use they are put to and the place where they can be used, etc., and may require periodic inspection. Please confirm these points with your sales representative or directly with this company.

Furthermore, regarding purchased products and delivered products, we request that you take adequate consideration of the necessity of rapid receiving inspections and of product management and maintenance even before receiving your products.

1. Free of Charge Warranty Period and Warranty Range

1-1 Free of charge warranty period

- (1) The product warranty period is "1 year from the date of purchase" or 24 month from the manufacturing date imprinted on the name place, whichever date is earlier.
- (2) However in cases where the use environment, conditions of use, use frequency and times, etc., have an effect on product life, this warranty period may not apply.
- (3) Furthermore, the warranty period for parts restored by Fuji Electric's Service Department is "6 month from the date that repairs are completed."

1-2 Warranty range

- (1) In the event that breakdown occurs during the product's warranty period which is the responsibility of Fuji Electric, Fuji Electric will replace or repair the part of the product that has broken down free of charge at the place where the product was purchased or where it was delivered. However, if the following cases are applicable, the terms of this warranty may not apply.
 - 1) The breakdown was caused by inappropriate conditions, environment, handling or use methods, etc. which are not specified in the catalog, operation manual, specifications or other relevant documents.
 - 2) The breakdown was caused by the product other than the purchased or delivered Fuji's product.
 - 3) The breakdown was caused by the product other than Fuji's product, such as the customer's equipment or software design etc.
 - 4) Concerning the Fuji's programmable products, the breakdown was caused by a program other than a program supplied by this company, or the results from using such a program.
 - 5) The breakdown was caused by modifications or repairs affected by a party other than Fuji Electric.
 - 6) The breakdown was caused by improper maintenance or replacement using consumables, etc. specified in the operation manual or catalog, etc.
 - 7) The breakdown was caused by a chemical or technical problem that was not foreseen when making practical application of the product at the time it was purchased or delivered.
 - 8) The product was not used in the manner the product was originally intended to be used.
 - 9) The breakdown was caused by a reason which is not this company's responsibility, such as lightning or other disaster.
- (2) Furthermore, the warranty specified herein shall be limited to the purchased or delivered product alone.
- (3) The upper limit for the warranty range shall be as specified in item (1) above and any damages (damage to or loss of machinery or equipment, or lost profits from the same, etc.) consequent to or resulting from breakdown of the purchased or delivered product shall be excluded from coverage by this warranty.

1-3. Trouble diagnosis

As a rule, the customer is requested to carry out a preliminary trouble diagnosis. However, at the customer's request, this company or its service network can perform the trouble diagnosis on a chargeable basis. In this case, the customer is asked to assume the burden for charges levied in accordance with this company's fee schedule.

2. Exclusion of Liability for Loss of Opportunity, etc.

Regardless of whether a breakdown occurs during or after the free of charge warranty period, this company shall not be liable for any loss of opportunity, loss of profits, or damages arising from special circumstances, secondary damages, accident compensation to another company, or damages to products other than this company's products, whether foreseen or not by this company, which this company is not be responsible for causing.

3. Repair Period after Production Stop, Spare Parts Supply Period (Holding Period)

Concerning models (products) which have gone out of production, this company will perform repairs for a period of 7 years after production stop, counting from the month and year when the production stop occurs. In addition, we will continue to supply the spare parts required for repairs for a period of 7 years, counting from the month and year when the production stop occurs. However, if it is estimated that the life cycle of certain electronic and other parts is short and it will be difficult to produce or produce those parts, there may be causes where it is difficult to provide repairs or supply spare parts even within this 7-year period. For details, please confirm at our company's business office or our service office.

4. Transfer Rights

In the case of standard products which do not include settings or adjustments in an application program, the products shall be transported to and transferred to the customer and this company shall not be responsible for local adjustments or trial operation.

5. Service Contents

The cost of purchased and delivered products does not include the cost of dispatching engineers or service costs. Depending on the request, these can be discussed separately.

6. Applicable Scope of Service

Above contents shall be assumed to apply to transactions and use of the country where you purchased the products. Consult the local supplier or Fuji for detail separately.