

Preface

Thank you for purchasing our FRENIC-Eco series of inverters.

This product is designed to drive a three-phase induction motor for fan and pump applications. Read through this instruction manual and be familiar with proper handling and operation of this product.

Improper handling might result in incorrect operation, a short life, or even a failure of this product as well as the motor.

Have this manual delivered to the end user of this product. Keep this manual in a safe place until this product is discarded.

Listed below are the other materials related to the use of the FRENIC-Eco. Read them in conjunction with this manual as necessary.



- FRENIC-Eco User's Manual
- RS-485 Communication User's Manual
- Catalog
- Relay Output Card "OPC-F1-RY" Instruction Manual
- Mounting Adapter for External Cooling "PB-F1" Installation Manual
- Panel-mount Adapter "MA-F1" Installation Manual
- FRENIC Loader Instruction Manual

The materials are subject to change without notice. Be sure to obtain the latest editions for use.

■ Safety precautions

Read this manual thoroughly before proceeding with installation, connections (wiring), operation, or maintenance and inspection. Ensure you have sound knowledge of the device and familiarize yourself with all safety information and precautions before proceeding to operate the inverter.

Safety precautions are classified into the following two categories in this manual.

 WARNING	Failure to heed the information indicated by this symbol may lead to dangerous conditions, possibly resulting in death or serious bodily injuries.
 CAUTION	Failure to heed the information indicated by this symbol may lead to dangerous conditions, possibly resulting in minor or light bodily injuries and/or substantial property damage.

Failure to heed the information contained under the CAUTION title can also result in serious consequences. These safety precautions are of utmost importance and must be observed at all times.

Application

WARNING

- FRENIC-Eco is designed to drive a three-phase induction motor. Do not use it for single-phase motors or for other purposes.
Fire or an accident could occur.
- FRENIC-Eco may not be used for a life-support system or other purposes directly related to the human safety.
- Though FRENIC-Eco is manufactured under strict quality control, install safety devices for applications where serious accidents or material losses are foreseen in relation to the failure of it.
An accident could occur.

Installation

WARNING

- Install the inverter on a nonflammable material such as metal.
Otherwise fire could occur.
- Do not place flammable matter nearby.
Doing so could cause fire.

CAUTION

- Do not support the inverter by its terminal block cover during transportation.
Doing so could cause a drop of the inverter and injuries.
- Prevent lint, paper fibers, sawdust, dust, metallic chips, or other foreign materials from getting into the inverter or from accumulating on the heat sink.
Otherwise, a fire or an accident might result.
- Do not install or operate an inverter that is damaged or lacking parts.
Doing so could cause fire, an accident or injuries.
- Do not get on a shipping box.
- Do not stack shipping boxes higher than the indicated information printed on those boxes.
Doing so could cause injuries.

Wiring

WARNING

- When wiring the inverter to the power source, insert a recommended molded case circuit breaker (MCCB) or residual-current-operated protective device (RCD)/a ground fault circuit interrupter(GFCI)(with overcurrent protection) in the path of power lines. Use the devices within the recommended current range.
- Use wires in the specified size.
Otherwise, fire could occur.
- Do not use one multicore cable in order to connect several inverters with motors.
- Do not connect a surge suppressor to the inverter's output (secondary) circuit.
Doing so could cause fire.
- Ground the inverter in compliance with the national or local electric code.
Otherwise, electric shock could occur.
- Qualified electricians should carry out wiring.
- Be sure to perform wiring after turning the power OFF.
Otherwise, electric shock could occur.
- Be sure to perform wiring after installing the inverter body.
Otherwise, electric shock or injuries could occur.
- Ensure that the number of input phases and the rated voltage of the product match the number of phases and the voltage of the AC power supply to which the product is to be connected.
Otherwise fire or an accident could occur.
- Do not connect the power source wires to output terminals (U, V, and W).
Doing so could cause fire or an accident.
- Generally, control signal wires are not enforced- insulated. If they accidentally touch any of live parts in the main circuit, their insulation coat may break for any reasons. In such a case, an extremely high voltage may be applied to the signal lines. Make a complete remedy to protect the signal line from contacting any hot high voltage lines.
Otherwise, an accident or electric shock could occur.

CAUTION

- Wire the three-phase motor to terminals U, V, and W of the inverter, aligning phases each other.
Otherwise injuries could occur.
- The inverter, motor and wiring generate electric noise. Take care of malfunction of the nearby sensors and devices. To prevent the motor from malfunctioning, implement noise control measures.
Otherwise an accident could occur.

WARNING

- Be sure to install the terminal block cover and the front cover before turning the power ON. Do not remove the covers while power is applied.

Otherwise electric shock could occur.



- Do not operate switches with wet hands.

Doing so could cause electric shock.

- If the retry function has been selected, the inverter may automatically restart and drive the motor depending on the cause of tripping.
(Design the machinery or equipment so that human safety is ensured after restarting.)
- If the stall prevention function (current limiter), automatic deceleration, and overload prevention control have been selected, the inverter may operate at an acceleration/deceleration time or frequency different from the commanded ones. Design the machine so that safety is ensured even in such cases.

Otherwise an accident could occur.

- The  key on the keypad is effective only when the keypad operation is enabled with function code F02 (= 0, 2 or 3). When the keypad operation is disabled, prepare an emergency stop switch separately for safe operations.

Switching the run command source from keypad (local) to external equipment (remote) by turning ON the "Enable communications link" command (LE) or "Switch run command 2/1" command (FR2/FR1), disables the  key. To enable the  key for an emergency stop, select the STOP key priority with function code H96 (= 1 or 3).

- If an alarm reset is made with the Run command signal turned ON, a sudden start will occur. Ensure that the Run command signal is turned OFF in advance.

Otherwise an accident could occur.

- If you enable the "Restart mode after momentary power failure" (Function code F14 = 3, 4, or 5), then the inverter automatically restarts running the motor when the power is recovered.
(Design the machinery or equipment so that human safety is ensured after restarting.)
- If you set the function codes wrongly or without completely understanding this instruction manual and the FRENIC-Eco User's Manual, the motor may rotate with a torque or at a speed not permitted for the machine.

An accident or injuries could occur.

- Do not touch the inverter terminals while the power is applied to the inverter even if the inverter stops.

Doing so could cause electric shock.

CAUTION

- Do not turn the main circuit power (circuit breaker) ON or OFF in order to start or stop inverter operation.
Doing so could cause failure.
- Do not touch the heat sink because they become very hot.
Doing so could cause burns.
- Setting the inverter to high speeds is easy. Before changing the frequency (speed) setting, check the specifications of the motor and machinery.
- The brake function of the inverter does not provide mechanical holding means.
Injuries could occur.

Setting control switches

WARNING

- Before setting up any internal control switches, turn OFF the power and wait more than five minutes for models of 30HP for 208V, 40HP for 460V or below, or ten minutes for models of 40HP for 208V, 50HP for 460V or above. Make sure that the LED monitor and charging lamp (on models of 40HP for 208V, 50HP for 460V or above) are turned OFF. Further, make sure, using a multimeter or a similar instrument, that the DC link bus voltage between the terminals P (+) and N (-) has dropped below the safe voltage (+25 VDC).
Otherwise electric shock could occur.

Maintenance and inspection, and parts replacement

WARNING

- Turn the power OFF and wait for at least five minutes for models of 30HP for 208V, 40HP for 460V or below, or ten minutes for models of 40HP for 208V, 50HP for 460V or above, before starting inspection. Further, check that the LED monitor and charging lamp (on models of 40HP for 208V, 50HP for 460V or above) are unlit and that the DC link bus voltage between the P (+) and N (-) terminals is lower than 25 VDC.
Otherwise, electric shock could occur.
- Maintenance, inspection, and parts replacement should be made only by qualified persons.
- Take off the watch, rings and other metallic objects before starting work.
- Use insulated tools.
Otherwise, electric shock or injuries could occur.

Disposal

CAUTION

- Treat the inverter as an industrial waste when disposing of it.
Otherwise injuries could occur.

Others

WARNING

- Never attempt to modify the inverter.
Doing so could cause electric shock or injuries.

GENERAL PRECAUTIONS

Drawings in this manual may be illustrated without covers or safety shields for explanation of detail parts. Restore the covers and shields in the original state and observe the description in the manual before starting operation.

Conformity with Low Voltage Directive in the EU

If installed according to the guidelines given below, inverters marked with CE can be considered to be compliant with the Low Voltage Directive 73/23/EEC.

CAUTION

1. Be sure to earth the grounding terminal G. Use an earth wire sized more than that of the power wires used in the power dispatch system. Do not use a residual-current-operated protective device (RCD)* or a ground fault circuit interrupter(GFCI)* as a sole mechanism of electric shock protection.
*With overcurrent protection.
2. Use an MCCB, RCD/GFCI or MC in conformity with EN or IEC standards.
3. When an RCD/GFCI is used for protection of electric shock caused by a direct or indirect contact to the live parts, insert **a type B RCD/GFCI** in input lines (primary) of the inverter for the 3-phase 208 V or 460 V power source.
4. Use inverters in an environment that does not exceed pollution degree 2. If inverters are to be used in an environment with pollution degree 3 or 4, place them in an enclosure of IP54 or above.
5. To protect human body from an electric shock caused by a contact to live parts, install inverters, AC reactor and input /output filter in the enclosure of IP2X. In the case where human body easily contacts to live parts, a top panel of the enclosure should be IP4X or higher.
6. Do not directly connect a copper wire to the grounding terminal. Use a crimp terminal with tin or equivalent plating to connect the earth wire.
7. When using inverters at an altitude of more than 6600ft(2000 m), note that the basic insulation applies to the insulation degree of the control circuitry. At an altitude of more than 9800ft(3000 m), inverters cannot be used.

Conformity with Low Voltage Directive in the EU (continued)



8. Use the wires listed in EN60204-1.

Power supply voltage	Nominal applied motor (HP)	Inverter type	MCCB or RCD/GFCI *1 Rated current (A)		Recommended wire size (mm ²)											
					Main power input ** [L1/R, L2/S, L3/T] Inverter's grounding [⊕]		Inverter outputs ** [U, V, W]	DC reactor [P ⁻ , P ⁺]	Control circuit	Aux. control power supply [R0, T0]	Aux. fan power supply [R1, T1]					
					W/DCR	W/o DCR			W/DCR			W/o DCR	Europe type terminal block			
Three-phase 208 V	1	FRN001F1S-2U	10	15	2.5	2.5	2.5	2.5	0.25 to 0.75	2.5						
	2	FRN002F1S-2U		20								30	4.0			
	3	FRN003F1S-2U		40								75		6.0	10	6.0
	5	FRN005F1S-2U										50	100	10	16	10
	7	FRN007F1S-2U	75	125	16	25	16	25								
	10	FRN010F1S-2U	100	150	25	35	25	35								
	15	FRN015F1S-2U		175	250	16x2	35x2	25x2				25x2				
	20	FRN020F1S-2U	200	300	95	50x2	95	95								
	25	FRN025F1S-2U		350		500	70x2	50x2				50x2				
	30	FRN030F1S-2U	250	350	-	-	50x2	70x2				50x2				
	40	FRN040F1S-2U		500			750	95x2					95x2			
	50	FRN050F1S-2U	350	-	50x2	70x2	50x2	50x2								
	60	FRN060F1S-2U			750	1050	95x2	95x2								
	75	FRN075F1S-2U	500	-	240	240	120x2	120x2								
100	FRN100F1S-2U															
125	FRN125F1S-2U															
Three-phase 460 V	1	FRN001F1S-4U	5	5	2.5	2.5	2.5	2.5	0.25 to 0.75	2.5						
	2	FRN002F1S-4U		10								15				
	3	FRN003F1S-4U	10	20	4.0											
	5	FRN005F1S-4U		15		30										
	7	FRN007F1S-4U	20	40	6.0	10	6.0	6.0								
	10	FRN010F1S-4U	30	50	4.0	6.0	4.0	4.0								
	15	FRN015F1S-4U	40	60	6.0	10	6.0	6.0								
	20	FRN020F1S-4U		75								100	16	10	10	
	25	FRN025F1S-4U	50	100	10	16	10	16								
	30	FRN030F1S-4U		75								100	16	10	16	
	40	FRN040F1S-4U	75	125	25	35	35	25								
	50	FRN050F1S-4U		150								200	50	35	35	
	60	FRN060F1S-4U	100	200	35	25x2	16x2	50								
	75	FRN075F1S-4U		250								300	16x2	50		
	100	FRN100F1S-4U	175	200	70	-	25x2	25x2								
	125	FRN125F1S-4U			95		120	50x2				95				
	150	FRN150F1S-4U	250	300	50x2	70x2	70x2	120								
	200	FRN200F1S-4U			70x2		120	70x2				70x2				
	250	FRN250F1S-4U	500	600	150	-	185	240								
	300	FRN300F1S-4U			185		240	120x2				120x2				
	350	FRN350F1S-4U	600	800	240	-	150x2	150x2								
400	FRN400F1S-4U	150x2			150x2		150x2	150x2								
450	FRN450F1S-4U	800	1000	185x2	-	185x2	185x2									
500	FRN500F1S-4U			240x2		240x2	240x2	240x2								
600	FRN600F1S-4U	1000	1200	240x2	-	185x3	240x3									
700	FRN700F1S-4U			185x3		240x3	240x3	240x3								
800	FRN800F1S-4U	1200	-	240x3	-	185x4	240x4									
900	FRN900F1S-4U			185x4		240x4	240x4	240x4								

*1 The frame size and model of the MCCB or RCD/GFCI (with overcurrent protection) will vary, depending on the power transformer capacity. Refer to the related technical documentation for details.

*2 The recommended wire size for main circuits is for the 70°C(158°F) 600V PVC wires used at an ambient temperature of 40°C(104°F).

Conformity with UL standards and CSA standards (cUL-listed for Canada)

UL/cUL-listed inverters are subject to the regulations set forth by the UL standards and CSA standards (cUL-listed for Canada) by installation within precautions listed below.

⚠ CAUTION

1. Solid state motor overload protection (motor protection by electronic thermal overload relay) is provided in each model.
Adjust function codes F10 to F12 to decide the protection level.
2. Suitable for use on a circuit capable of delivering not more than 100,000 rms three-phase symmetrical amperes, 240 Volts maximum for 208V class input 30HP or less, 230 Volts maximum for 208V class input 40HP or above or 480 Volts maximum for 460V class input.
3. Use 60°C/75°C Cu wire only.
4. Use Class 1 wire only.
5. Field wiring connections must be made by a UL Listed and CSA Certified closed-loop terminal connector sized for the wire gauge involved. Connector must be fixed using the crimp tool specified by the connector manufacturer.
6. All circuits with terminals L1/R, L2/S, L3/T, R0, T0, R1, T1 must have a common disconnect and be connected to the same pole of the disconnect if the terminals are connected to the power supply.

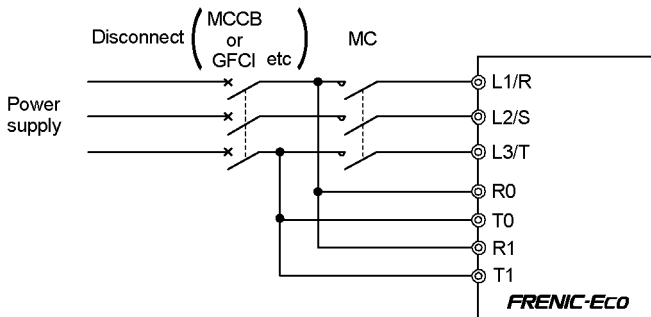

Conformity with UL standards and CSA standards (cUL-listed for Canada) (continued)



7. Install UL-listed fuses or circuit breaker between the power supply and the inverter, referring to the table below.

Power supply voltage	Inverter type	Required torque lb-in (N·m)			Wire size AWG (mm ²)				Class J fuse size (A)	Circuit breaker trip size (A)
		Main terminal	Aux. Control Power Supply R0, T0	Control circuit	Main terminal	Aux. Control Power Supply R0, T0	Aux. Fan Power Supply R1, T1	Control circuit		
				Europe type terminal block				Europe type terminal block		
Three-phase 208 V	FRN001F1S-2U	15.9 (1.8)	10.6 (1.2)	4.4 (0.5)	14 (2.1)	14 (2.1)	-	20 (0.5)	10	15
	FRN002F1S-2U								15	15
	FRN003F1S-2U								20	20
	FRN005F1S-2U	33.6 (3.8)			12 (3.3)				35	30
	FRN007F1S-2U				8 (8.4)				60	50
	FRN010F1S-2U	51.3 (5.8)			4 (21.2)				70	70
	FRN015F1S-2U				3 (26.7)				100	100
	FRN020F1S-2U				2 (33.6)				125	125
	FRN025F1S-2U	119.4 (13.5)			1/0 (53.5)				150	150
	FRN030F1S-2U				3/0 (85.0)				175	175
	FRN040F1S-2U	238.9 (27)			4/0 (107.2)				200	200
	FRN050F1S-2U				300 (152)				225	225
	FRN060F1S-2U				2/0x2 (67.4)				300	300
	FRN075F1S-2U	424.7 (48)			4/0x2 (107.2)				350	350
	FRN100F1S-2U								400	400
	FRN125F1S-2U									
Three-phase 460 V	FRN001F1S-4U	15.9 (1.8)	10.6 (1.2)	4.4 (0.5)	14 (2.1)	14 (2.1)	-	20 (0.5)	6	15
	FRN002F1S-4U								10	15
	FRN003F1S-4U								15	20
	FRN005F1S-4U	33.6 (3.8)			12 (3.3)				30	30
	FRN007F1S-4U				10 (5.3)				40	40
	FRN010F1S-4U	51.3 (5.8)			8 (8.4)				50	50
	FRN015F1S-4U				6 (13.3)				80	70
	FRN020F1S-4U				4 (21.2)				100	80
	FRN025F1S-4U	119.4 (13.5)			2 (33.6)				125	125
	FRN030F1S-4U				1 (42.4)				150	150
	FRN040F1S-4U	238.9 (27)			1/0 (53.5)				175	175
	FRN050F1S-4U				3x2 (26.7)				200	200
	FRN060F1S-4U				4/0 (107.2)				225	225
	FRN075F1S-4U	424.7 (48)			250 (127)				300	300
	FRN100F1S-4U				2/0x2 (67.4)				400	400
	FRN125F1S-4U	238.9 (27)			500 (253)				450	450
	FRN150F1S-4U				4/0x2 (107.2)				500	500
	FRN200F1S-4U				300x2 (152)				600	600
	FRN250F1S-4U	424.7 (48)			350x2 (177)				700	700
	FRN300F1S-4U				400x2 (203)				1000	1000
	FRN350F1S-4U	238.9 (27)			300x3 (152)				1200	1200
	FRN400F1S-4U				350x3 (177)				1500	1500
	FRN450F1S-4U				300x4 (152)				1800	1800
	FRN500F1S-4U	424.7 (48)			350x4 (177)					
FRN600F1S-4U	400x4 (203)									
FRN700F1S-4U										
FRN800F1S-4U										
FRN900F1S-4U										

* Select the rated current of a fuse or a circuit breaker which is suitable to the connecting wire size.

■ Precautions for use

In running general-purpose motors	Driving a 460V general-purpose motor	When driving a 460V general-purpose motor with an inverter using extremely long wires, damage to the insulation of the motor may occur. Use an output circuit filter (OFL) if necessary after checking with the motor manufacturer. Fuji motors do not require the use of output circuit filters because of their reinforced insulation.
	Torque characteristics and temperature rise	When the inverter is used to run a general-purpose motor, the temperature of the motor becomes higher than when it is operated using a commercial power supply. In the low-speed range, the cooling effect will be weakened, so decrease the output torque of the motor.
	Vibration	When an inverter-driven motor is mounted to a machine, resonance may be caused by the natural frequencies of the machine system. Note that operation of a 2-pole motor at 60 Hz or higher may cause abnormal vibration. * The use of a rubber coupling or vibration dampening rubber is recommended. * Use the inverter's jump frequency control feature to skip the resonance frequency zone(s).
	Noise	When an inverter is used with a general-purpose motor, the motor noise level is higher than that with a commercial power supply. To reduce noise, raise carrier frequency of the inverter. Operation at 60 Hz or higher can also result in higher noise level.
In running special motors	Explosion-proof motors	When driving an explosion-proof motor with an inverter, use a combination of a motor and an inverter that has been approved in advance.
	Submersible motors and pumps	These motors have a larger rated current than general-purpose motors. Select an inverter whose rated output current is greater than that of the motor. These motors differ from general-purpose motors in thermal characteristics. Set a low value in the thermal time constant of the motor when setting the electronic thermal function.
	Brake motors	For motors equipped with parallel-connected brakes, their braking power must be supplied from the primary circuit. If the brake power is connected to the inverter's output circuit by mistake, the brake will not work. Do not use inverters for driving motors equipped with series-connected brakes.
	Geared motors	If the power transmission mechanism uses an oil-lubricated gearbox or speed changer/reducer, then continuous motor operation at low speed may cause poor lubrication. Avoid such operation.
	Synchronous motors	It is necessary to take special measures suitable for this motor type. Contact your Fuji Electric representative for details.
	Single-phase motors	Single-phase motors are not suitable for inverter-driven variable speed operation. Use three-phase motors.
Environmental conditions	Installation location	Use the inverter within the ambient temperature range from -10 to +50°C (14 to 122°F). The heat sink of the inverter may become hot under certain operating conditions, so install the inverter on nonflammable material such as metal. Ensure that the installation location meets the environmental conditions specified in Chapter 2, Section 2.1 "Operating Environment."

Combination with peripheral devices	Installing an MCCB or RCD/GFCI	Install a recommended molded case circuit breaker (MCCB) or residual-current-operated protective device (RCD)/a ground fault circuit interrupter (GFCI) (with overcurrent protection) in the primary circuit of the inverter to protect the wiring. Ensure that the circuit breaker rated current is equivalent to or lower than the recommended rated current.
	Installing an MC in the secondary circuit	If a magnetic contactor (MC) is mounted in the inverter's output (secondary) circuit for switching the motor to commercial power or for any other purpose, ensure that both the inverter and the motor are completely stopped before you turn the MC ON or OFF. Remove the magnet contactor (MC) already installed and built-in surge suppressor from the inverter's output (secondary) circuit before installing the MC to switch the motor power.
	Installing an MC in the primary circuit	Do not turn the magnetic contactor (MC) in the primary circuit ON or OFF more than once an hour as an inverter failure may result. If frequent starts or stops are required during motor operation, use (FWD)/(REV) signals or the RUN/STOP key.
	Protecting the motor	The electronic thermal function of the inverter can protect the motor. The operation level and the motor type (general-purpose motor, inverter motor) should be set. For high-speed motors or water-cooled motors, set a small value for the thermal time constant and protect the motor. If you connect the motor thermal relay to the motor with a long wire, a high-frequency current may flow into the wiring stray capacitance. This may cause the relay to trip at a current lower than the set value for the thermal relay. If this happens, lower the carrier frequency or use the output circuit filter (OFL).
	Use of power-factor correcting capacitor	Do not mount power-factor correcting capacitors in the inverter's primary circuit. (Use the DC reactor to improve the inverter power factor.) Do not use power-factor correcting capacitors in the inverter's output (secondary) circuit. An overcurrent trip will occur, disabling motor operation.
	Use of surge suppressor	Do not connect a surge suppressor to the inverter's output (secondary) circuit.
	Reducing noise	Use of a filter and shielded wires is typically recommended to satisfy EMC Directives.
	Measures against surge currents	If an overvoltage trip occurs while the inverter is stopped or operated under a light load, it is assumed that the surge current is generated by open/close of the power-factor correcting capacitor in the power system. * Connect a DC reactor to the inverter.
Megger test	When checking the insulation resistance of the inverter, use a 500 V megger and follow the instructions contained in Chapter 7, Section 7.5 "Insulation Test."	
Wiring	Control circuit wiring length	When using remote control, limit the wiring length between the inverter and operator box to 67ft (20m) or less and use twisted pair or shielded wire.
	Wiring length between inverter and motor	If long wiring is used between the inverter and the motor, the inverter will overheat or trip as a result of overcurrent (high-frequency current flowing into the stray capacitance) in the wires connected to the phases. Ensure that the wiring is shorter than 164ft (50m). If this length must be exceeded, lower the carrier frequency or mount an output circuit filter (OFL).
	Wiring size	Select wires with a sufficient capacity by referring to the current value or recommended wire size.
	Wiring type	When several inverters drive motors, do not use one multicore cable in order to connect several inverters with motors.
	Grounding	Securely ground the inverter using the grounding terminal.

Selecting inverter capacity	Driving general-purpose motor	Select an inverter according to the applicable motor ratings listed in the standard specifications table for the inverter. When high starting torque is required or quick acceleration or deceleration is required, select an inverter with a capacity one size greater than the standard.
	Driving special motors	Select an inverter that meets the following condition: Inverter rated current > Motor rated current
Transportation and storage	When transporting or storing inverters, follow the procedures and select locations that meet the environmental conditions listed in Chapter 1, Section 1.3 "Transportation" and Section 1.4 "Storage Environment."	

How this manual is organized

This manual is made up of chapters 1 through 10.

Chapter 1 BEFORE USING THE INVERTER

This chapter describes acceptance inspection and precautions for transportation and storage of the inverter.

Chapter 2 MOUNTING AND WIRING OF THE INVERTER

This chapter provides operating environment, precautions for installing the inverter, wiring instructions for the motor and inverter.

Chapter 3 OPERATION USING THE KEYPAD

This chapter describes inverter operation using the keypad. The inverter features three operation modes (Running, Programming and Alarm modes) which enable you to run and stop the motor, monitor running status, set function code data, display running information required for maintenance, and display alarm data.

Chapter 4 OPERATION

This chapter describes preparation to be made before running the motor for a test and practical operation.

Chapter 5 FUNCTION CODES

This chapter provides a list of the function codes. Function codes to be used often and irregular ones are described individually.

Chapter 6 TROUBLESHOOTING

This chapter describes troubleshooting procedures to be followed when the inverter malfunctions or detects an alarm condition. In this chapter, first check whether any alarm code is displayed or not, and then proceed to the troubleshooting items.

Chapter 7 MAINTENANCE AND INSPECTION

This chapter describes inspection, measurement and insulation test which are required for safe inverter operation. It also provides information about periodical replacement parts and guarantee of the product.

Chapter 8 SPECIFICATIONS

This chapter lists specifications including output ratings, control system, external dimensions and protective functions.

Chapter 9 LIST OF PERIPHERAL EQUIPMENT AND OPTIONS

This chapter describes main peripheral equipment and options which can be connected to the FRENIC-Eco series of inverters.

Chapter 10 CONFORMITY WITH STANDARDS

This chapter describes standards with which the FRENIC-Eco series of inverters comply.

Icons

The following icons are used throughout this manual.



This icon indicates information which, if not heeded, can result in the inverter not operating to full efficiency, as well as information concerning incorrect operations and settings which can result in accidents.



This icon indicates information that can prove handy when performing certain settings or operations.



This icon indicates a reference to more detailed information.

Table of Contents

Preface	i	4.1.1 Inspection and preparation prior to powering on	4-1
■ Safety precautions	i	4.1.2 Turning ON power and checking	4-1
■ Precautions for use	x	4.1.3 Preparation before running the motor for a test--Setting function code data	4-1
How this manual is organized	xiii	4.1.4 Test run --Setting function code data	4-4
Chapter 1 BEFORE USING THE INVERTER	1-1	4.2 Operation	4-4
1.1 Acceptance Inspection	1-1	Chapter 5 FUNCTION CODES	5-1
1.2 External View and Terminal Blocks	1-2	5.1 Function Code Tables	5-1
1.3 Transportation	1-4	5.2 Overview of Function Codes	5-23
1.4 Storage Environment	1-4	Chapter 6 TROUBLESHOOTING	6-1
1.4.1 Temporary storage	1-4	6.1 Before Proceeding with Troubleshooting	6-1
1.4.2 Long-term storage	1-4	6.2 If No Alarm Code Appears on the LED Monitor	6-2
Chapter 2 MOUNTING AND WIRING OF THE INVERTER	2-1	6.2.1 Motor is running abnormally	6-2
2.1 Operating Environment	2-1	6.2.2 Problems with inverter settings	6-7
2.2 Installing the Inverter	2-1	6.3 If an Alarm Code Appears on the LED Monitor	6-8
2.3 Wiring	2-6	6.4 If an Abnormal Pattern Appears on the LED Monitor while No Alarm Code is Displayed	6-19
2.3.1 Removing and mounting the terminal block (TB) cover and the front cover	2-6	Chapter 7 MAINTENANCE AND INSPECTION	7-1
2.3.2 Removing and mounting the cable guide plate (for models of 1 to 25HP for 208V and 1 to 30HP for 460V)	2-10	7.1 Daily Inspection	7-1
2.3.3 Terminal arrangement diagram and screw specifications	2-11	7.2 Periodic Inspection	7-1
2.3.4 Recommended wire sizes	2-14	7.3 List of Periodical Replacement Parts	7-3
2.3.5 Wiring precautions	2-15	7.3.1 Judgment on service life	7-3
2.3.6 Wiring for main circuit terminals and grounding terminals	2-15	7.4 Measurement of Electrical Amounts in Main Circuit	7-5
2.3.7 Wiring for control circuit terminals	2-24	7.5 Insulation Test	7-6
2.3.8 Setting up slide switches and handling control circuit terminal symbol plate	2-34	7.6 Inquiries about Product and Guarantee	7-7
2.4 Mounting and Connecting a Keypad	2-35	Chapter 8 SPECIFICATIONS	8-1
2.4.1 Mounting style and parts needed for connection	2-35	8.1 Standard Models	8-1
2.4.2 Mounting/installing steps	2-36	8.1.1 Three-phase 208 V	8-1
2.5 Cautions Relating to Harmonic Component, Noise, and Leakage Current	2-38	8.1.2 Three-phase 460 V	8-2
Chapter 3 OPERATION USING THE MULTI-FUNCTION KEYPAD	3-1	8.2 Specifications of Keypad Related	8-4
3.1 Key, LED, and LCD Monitors on the Keypad	3-1	8.2.1 General specifications of keypad	8-4
3.2 Overview of Operation Modes	3-4	8.2.2 Communications specifications of keypad	8-4
3.3 Running Mode	3-5	8.2.3 Data transmission specifications	8-5
3.3.1 Running/stopping the motor	3-5	8.3 Common Specifications	8-6
3.3.2 Setting up the frequency and PID process commands	3-8	8.4 Terminal Specifications	8-8
3.3.3 LED monitor (Monitoring the running status)	3-12	8.4.1 Terminal functions	8-8
3.4 Programming Mode	3-13	8.4.2 Running the inverter with keypad	8-9
3.4.1 Setting function codes -- "1. Data Setting"	3-14	8.4.3 Running the inverter by terminal commands	8-10
3.4.2 Setting up function codes quickly using Quick setup -- "0. QUICK SET"	3-17	8.5 External Dimensions	8-12
3.4.3 Checking changed function codes -- "2. DATA CHECK"	3-17	8.5.1 Standard models	8-12
3.4.4 Monitoring the running status -- "3. OPR MNTR"	3-18	8.5.2 DC reactor	8-15
3.4.5 Checking I/O signal status -- "4. I/O CHECK"	3-20	8.5.3 Multi-function Keypad	8-16
3.4.6 Reading maintenance information -- "5. MAINTENANC"	3-23	8.6 Protective Functions	8-17
3.4.7 Reading alarm information -- "6. ALM INF"	3-26	Chapter 9 LIST OF PERIPHERAL EQUIPMENT AND OPTIONS	9-1
3.4.8 Viewing cause of alarm -- "7. ALM CAUSE"	3-29	Chapter 10 CONFORMITY WITH STANDARDS	10-1
3.4.9 Data copying -- "8. DATA COPY"	3-31	10.1 Conformity with UL Standards and Canadian Standards (cUL-listed for Canada)	10-1
3.4.10 Measuring load factor -- "9. LOAD FCTR"	3-38	10.1.1 General	10-1
3.4.11 Changing function codes covered by Quick setup -- "10. USER SET"	3-41	10.1.2 Considerations when using FRENIC-Eco as a product certified by UL or cUL	10-1
3.4.12 Performing communication debugging -- "11. COMM DEBUG"	3-42	10.2 Conformity with EU Directives	10-1
3.5 Alarm Mode	3-43	10.3 Conformity with Low Voltage Directive	10-1
3.6 Other Precautions	3-45	10.3.1 General	10-1
3.6.1 Function code setting for F02 (Run and operation)	3-45	10.3.2 Considerations when using FRENIC-Eco as a product in conformity with Low Voltage Directive	10-1
3.6.2 Remote/local operation	3-45	10.4 Harmonic Component Regulation in the EU	10-2
3.6.3 Tuning motor parameters	3-46	10.4.1 General	10-2
Chapter 4 RUNNING THE MOTOR	4-1	10.4.2 Conformity with the harmonics regulation	10-2
4.1 Running the Motor for a Test	4-1	10.5 Conformity with the EMC Directive in the EU	10-3
		10.5.1 General	10-3
		10.5.2 EMC-compliant filter (Option)	10-3
		10.5.3 Recommended installation of EMC-compliant filter	10-5
		10.5.4 EMC-compliant environment and class	10-6