

# Technical Development for New Global MCCB and ELCB

Masaaki Nakano  
Toshiyuki Onchi  
Shuichi Sugiyama

## 1. Introduction

Molded case circuit breakers (MCCB) and earth leakage circuit breakers (ELCB) function to protect wiring, equipment and people from overcurrent and ground faults, and are used throughout the world and are installed in virtually all devices, machines, equipment and buildings that use electricity. The performance of MCCB and ELCB is provided for by the standard by the country on the region. However, the content also has a different part by the difference and the historical background of the idea by the composition of the electrical system.

At present, there is a movement to unify the different standards. However, actually, various standards such as IEC (Europe, Asia), UL (United States), GB (China, essentially the same as IEC), JIS (Japan, some content is essentially the same as IEC and some content is specific to Japan) exist throughout the world, and product lines that conform to these standards, i.e., IEC standards, UL standards, JIS standard, etc., are being developed and supplied. Thus the new global MCCB and ELCB aim to realize a truly global product line, and were developed with the goal of providing a single model that conforms to all these various standards.

This paper describes the basic technology for realizing products that satisfy various global standards simultaneously maintaining the existing dimensions of JIS-compliant products.

## 2. Structure of the Newly Developed MCCB and ELCB

The newly developed MCCB and ELCB are the same size as well as “Twin Breakers” of an existing product. Figure 1 shows the externals.

Figure 2 shows the structure of the new ELCB. In conformance with IEC 60947-2, Annex B, 3rd Edition, the earth leakage detector circuit is equipped with a newly developed power circuit for supplying electric power from each phase so that earth leakage protection can be implemented even if one of the three phases is operating as an open-phase. Moreover, abnormali-

Fig.1 Appearance of the new MCCB/ELCB

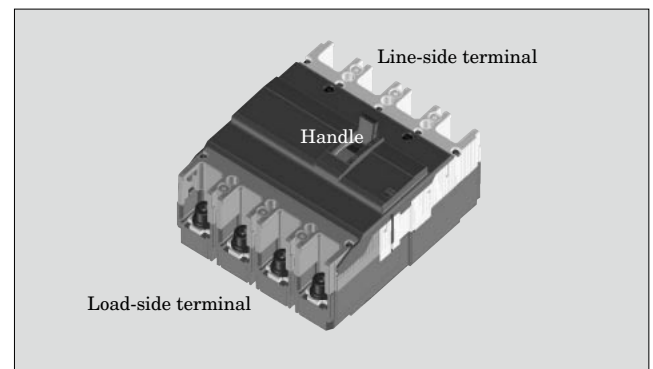
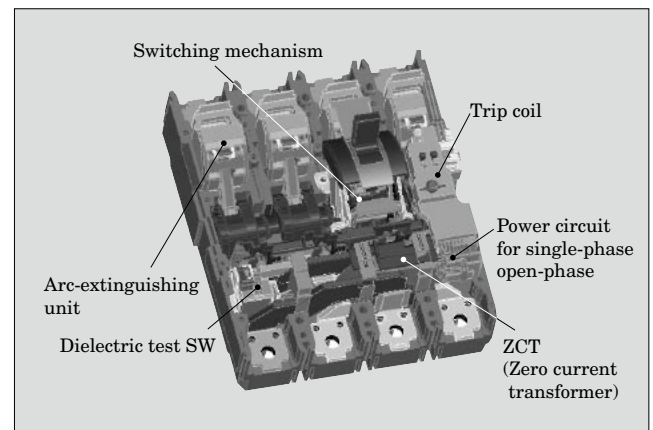

Fig.2 Structure of the new ELCB



ties in the equipment or wiring are usual verified by measuring the withstand voltage of the circuit, but the voltage applied in this case is excessive for the internal circuit elements of the ELCB, and will result in device failure. To prevent such failure, Fuji Electric equips the ELCB with a newly developed dielectric test switch that is isolated from the portions of the circuit in order to conduct current during inspection.

The MCCB shares the same case, circuit breaker, switchgear, and has the same construction as the ELCB, with the exception of those ELCB modules involved in the operation or in the detection of leakage current.

### 3. Technical Development for the New MCCB and ELCB

This paper presents examples of the technology used in developing the high-capacity current breaking performance, the earth leakage protection operation that is compatible with single-phase open-phase operation, and the high-strength case structure.

#### 3.1 High capacity breaking performance

The breaking duty of a low voltage breaker is prescribed in the IEC standard according to the  $I_{CS}$  duty (O-CO-CO\*<sup>1</sup>), and is prescribed in the UL standard according to a single-phase ground fault test in which a large recovery voltage is applied between phases. A single model that supports these various duty cycles would require large external dimensions and thus would be difficult to satisfy customer requirements. In the search for a solution, advances in circuit breaking technology will play a crucial role. The optimization of gas flow control during circuit breaking and of sidewall structure is discussed below.

##### 3.1.1 Gas flow control

In the past, when breaking a large current such as a short-line fault current, a magnetic field is applied to the arc via an arc plate and a magnetic body such as a magnetic yoke installed at the periphery of stationary and movable contacts. The electromagnetic force generated by interaction with the current that flows in the arc acts to drive and cool off the arc, pushing inward on the arc plate and interrupting the current flow. At this time, the arc causes the breaking unit to be at a high temperature and high pressure, and gas flows toward low-pressure regions. This time's development work aims to achieve even higher capacity breaking performance by utilizing this gas flow, in addition to the electromagnetic force described above. Figure 3 shows the gas flow at this time. As can be seen in the figure, the gas flow is divided into a portion flowing through the arc plate and toward the line-side, and a portion flowing oppositely through the switchgear and the overcurrent/earth leakage detector and toward the load-side. By increasing the gas flow toward the line-side, the arc can be driven toward the arc plate.

Figure 4 shows examples of the measurement of various arc plate potentials for the purpose of verifying whether the arc is being pushed inward. The verification is carried out under conditions of single-phase circuit interruption with a rated voltage of 480 V per delta connection as specified by the strict regulations of the high recovery voltage of UL 489. From the measured results, it is determined that the arc is being pushed toward several arc plates due to the potential of each arc plate. The results shown in Fig. 5 illustrate the relationship to the success or failure of the cur-

\*1: O-CO-CO is Off - Cut off - Cut off.

Fig.3 Schematic of current breaking operation

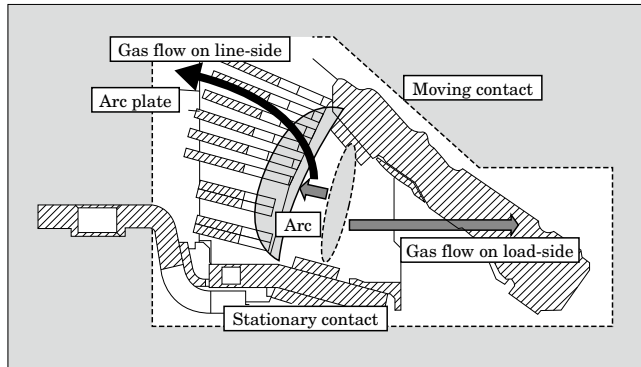

Fig.4 Example of arc plate measurement

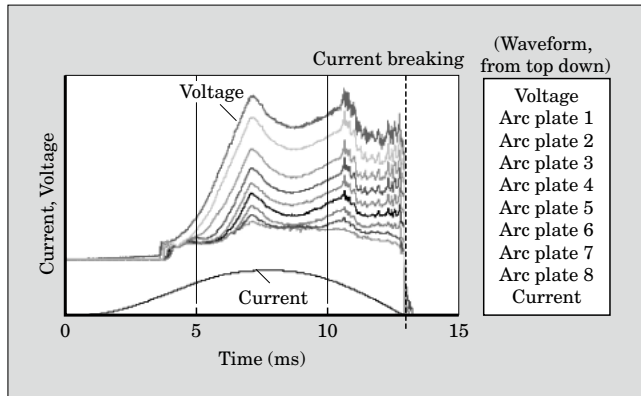
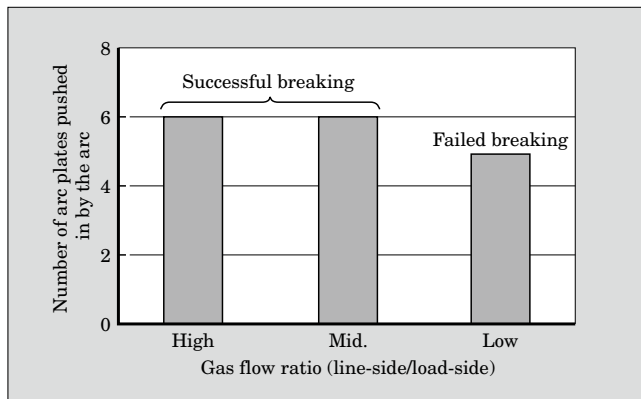

Fig.5 Number of arc plates pushed in by the arc and breaking performance



rent breaking. As can be seen in this figure, the ratio of the flow rates of gas exhausted to the line-side and load-side must be greater than a certain value, and by optimizing the shape of the exhaust to the line-side and to the load-side, and by controlling the flow of gas blown to the arc, there is an increase in the number of arc plates pushed inward by the arc, thereby enabling circuit breaking.

##### 3.1.2 Sidewall structure of the circuit breaker

At the circuit breaker, a plastic resin sidewall is used to surround the arc, and the arc is cooled by the ablation effect of the resin. To improve the current limiting performance and realize higher capacity breaking

performance, the distance between the resin and the arc must be reduced to enhance the ablation effect. However, due to the increased quantity of gas vaporization from the resin and the increase arc voltage due to cooling, the internal pressure increases and may cause damage to the case. With Fuji Electric's new developments, the sidewall structure is optimized so that the increase in internal pressure is suppressed while high-capacity breaking performance is realized.

From an oscillogram captured at the time of short-circuit current breaking, it can be seen that the current first reaches a peak value, and then after some time, both the arc voltage and internal pressure either rise at approximately the same time and reach peak values, or the internal pressure will reach its peak value after a slight delay. In Fuji Electric's new developments, attention focused on this time delay, and at the beginning of the breaking operation, or in other words, when the movable contact is within a short distance of the stationary contact and the sidewall gap is narrower, ablation enhances the current-limiting performance so that the peak value of the current is limited, and at the end of the current breaking operation, or in other words, when the movable contact is a distance away from the stationary contact and the sidewall gap is increased, the increase in generated ablation gas and in arc voltage are suppressed, thereby enabling the rise in internal pressure to be mitigated.

Figure 6 shows the shape of the sidewall gap and Fig. 7 shows the results of verification testing. From these figures, it can be seen that the sidewall becomes narrower in the vicinity of the stationary contact and

Fig.6 Shape of resin sidewalls

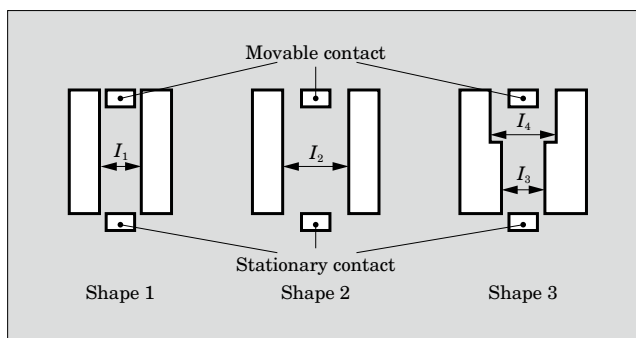
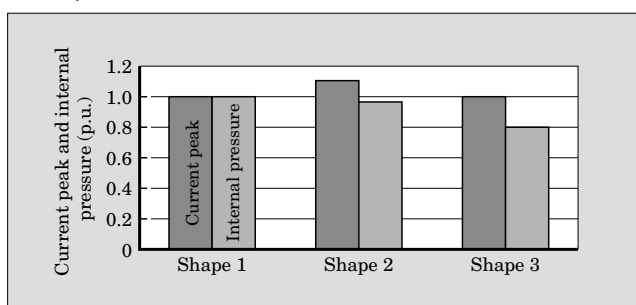

Fig.7 Effect of sidewall shape on current and rise in internal pressure



becomes wider at a distance from the stationary contact, and as a result, the current peak is suppressed to the same extent as when the sidewall is narrow (shape 1), and a rise in internal pressure is mitigated.

The above discussion concerned optimization of the gas flow control and sidewall shape, but by also using simulations to optimize the shape of the stationary contact, movable contact, arc plate, magnetic yoke and the like of the circuit breaker to achieve high-capacity breaking performance, in addition to conformance with IEC and JIS standards, is also possible to interrupt current with a single model that supports the rated voltage of 480 V per delta connection as specified in UL 489, which had been difficult to support in the past.

### 3.2. Single-phase open-phase operation for earth leakage protection

IEC 60947 requires the capability to implement earth leakage protection even when one of the three phases is operating in an open-phase mode. Moreover, the same category of regulations has also been added to JIS C 8201.

Technical developments for a power circuit that supplies power to an earth leakage relay part and for a trip coil are described below.

#### 3.2.1 Power circuit

So that power can be supplied to the trip coil of an earth leakage relay during single-phase open-phase operation, the power supplied to the detector and relay circuits must be changed from two to three phases. This is because, with the two-phase method, power cannot be supplied if one phase operates as an open-phase, but with the three-phase method, even if one phase operates as an open-phase, power can still be supplied by the remaining two phases. With the three-phase method, the supply voltage during single-phase open-phase operation is lower than usual. Because it is necessary, even in this case, to supply power stably to the trip coil, a two-stage transistor method is employed that combines two types of transistors, a high-breakdown voltage transistor for changing a high voltage to a low voltage and a low-breakdown voltage transistor for making the load current a constant current.

Figure 8 shows a comparison of the circuit configurations in the conventional method and the newly developed method, and Fig. 9 shows a comparison of the current versus voltage characteristics of the same circuits. As can be seen in these figures, the constant current characteristics have been greatly improved. Moreover, the mounting area has been decreased by 71 % and the power consumption decreased by 43 % compared to the conventional method.

#### 3.2.2 Trip coil for earth leakage relay

Figure 10 shows the structure of the trip coil. When an earth leakage has been detected, the trip coil receives an output signal from the detection circuit and causes the plunger to move. Releasing the latch of a switchgear (not shown in the figure) causes the ELCB

to trip. Usually, the attractive force of a permanent magnet compresses a spring and holds the plunger at a lower position. When an earth leakage occurs, current flows in the coil, generating a magnetic flux having an orientation opposite that of the permanent magnet, and the repulsive force of the spring causes the plunger to move upward and the ELCB to trip.

With the reduction in internal space as the result

Fig.8 Comparison of power circuits

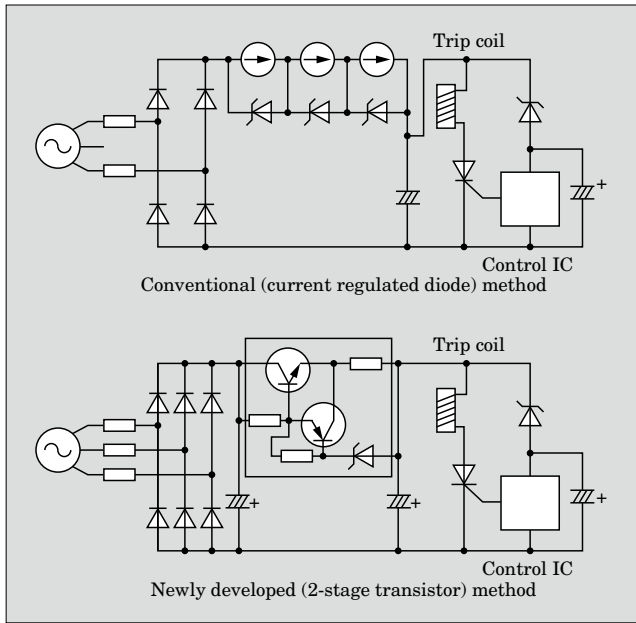

Fig.9 Comparison of power circuit characteristics

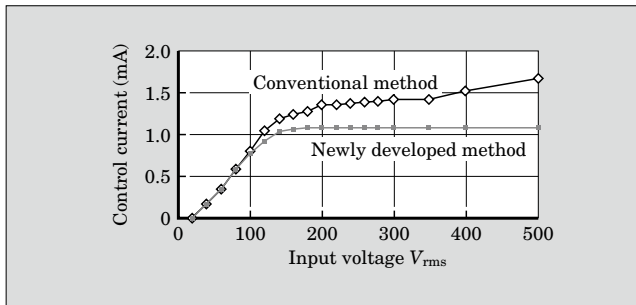
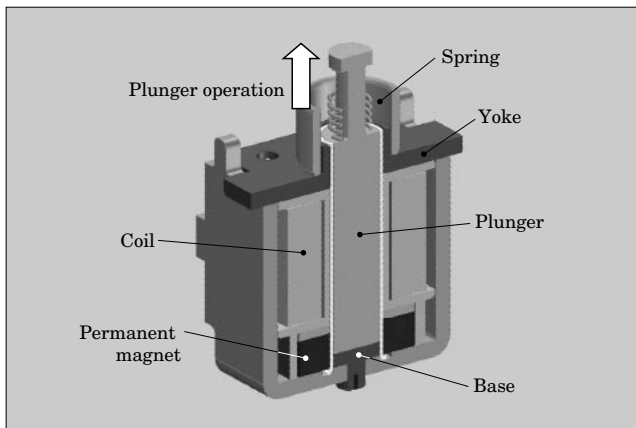

Fig.10 Trip coil structure



of internally housing the abovementioned power supply circuit capable of open-phase operation, Fuji Electric developed a simulator for analyzing the operation of the trip coil and optimized the trip coil. As a result, volume has been reduced by approximately 50 % compared to the previous size.

The trip coil is required to operate for short time durations on the order of milliseconds. However, because parameters of the magnetic circuit and electrical circuit vary widely and have a mutual dependence that is influenced by the plunger location, computation of those parameters must be performed with precision, and use of the general analytic technique of finite element analysis to analyze trip coil operation is impractical because of the large amount of labor and analysis time that would be required. Thus, Fuji Electric devised mathematical formulations of the magnetic circuit system, the electric circuit system and the mechanical system, and coupled these formulations to develop a simulator for analyzing operation of the trip coil.

Figure 11 shows an example analysis of the trip coil operation. Having a maximum analysis error of approximately 10 %, this simulation confirms the absence of any practical problems and was used when examining the robustness achieved through quality engineering techniques, and resulted in an optimal shape of the trip coil and an optimized control power circuit as shown in Fig. 8.

### 3.3 Stronger case structure

As discussed in section 3.1.2, with Fuji Electric's

Fig.11 Example analysis of trip coil operation

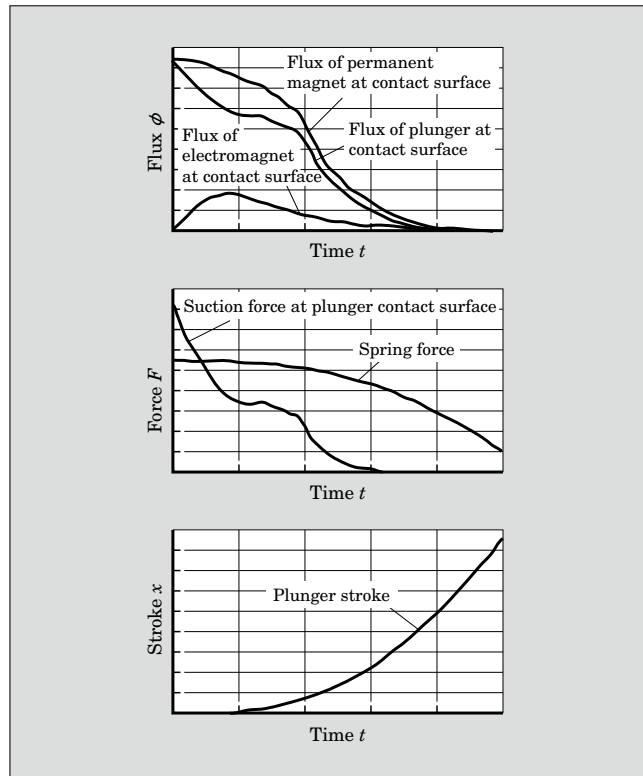
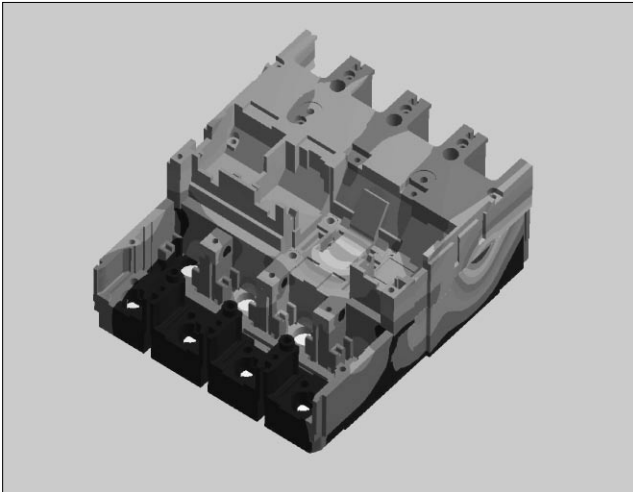

Fig.12 Example analysis of strain on case



new development, the sidewall shape of the arc plate was optimized to mitigate the rise in pressure inside the case. Further, as will be discussed below, the strength of the case was analyzed and its structure optimized to prevent damage due to a rise in pressure.

The simulator-based analysis was used in advance verification testing into which the case interior pressure distribution parameters, obtained from the analysis results, were input, and was also used to perform an integral analysis that took into consideration the screws used to fasten together the separate portions of the case. Figure 12 shows an example of the strain analysis during short-circuit current breaking.

Based on the results, the simulated data was compared to actual test results of short-circuit current

breaking, verification testing performed, and the case structure was strengthened.

#### 4. Conclusion

The development of a low-pressure circuit breaker depends upon how well other related phenomena (characteristics or performance) are controlled. For example, the factors having the greatest impact on the structure during short-circuit current breaking are temperature and pressure, which both of which rise within an extremely short time interval of several milliseconds to 10 milliseconds. The temperature rises to 10,000 K at the center of the arc, and the pressure rises from atmospheric pressure to several MPa, and the rising temperature and pressure mutually affect each other, and ultimately determine whether the circuit is interrupted. In the past, phenomena that were directly related to performance, such as current and voltage, were measured at the outer face of the circuit breaker, but to realize further improvement in performance, it is necessary to assess and control gas flow, temperature, pressure distribution and other phenomena that occur inside the breaker. Numerical calculation is a powerful tool for that task, and collecting the supporting data is of great importance. For that purpose, technology must be developed for the precise measurement of phenomena occurring within a short time under conditions of extraordinarily high temperature and pressure.

Fuji Electric's new technical developments are only a first step, and we humbly request continued guidance and support from all concerned parties.

