

Advanced Information and Control Software Packages for the MICREX-NX

Takashi Ikeda
Masato Nakano

1. Introduction

With the development of information technology (IT) recently, control systems have evolved toward more advanced information integration and greater networking capability. This evolution is supported by trends toward higher system efficiency and integration, user requirements on plant safety, internet security, and compliance with industrial standards and various regulations.

The new information and control system MICREX-NX is based on a concept of vertical and horizontal integration, and has high scalability enable to apply to small to large-scale plants. In an integrated engineering environment, the MICREX-NX supports the use of highly intelligent field devices, integrates process and discrete systems, and links up with upper-level manufacturing execution system (MES). These functions are realized by combining the basic functions of the MICREX-NX with various information control packages to built-in modeled (abstract) system elements within a common engineering environment.

This paper introduces information and control packages for MICREX-NX, the process device manager (SIMATIC*1 PDM), the batch system (SIMATIC Batch), and the route control system (SIMATIC Route Control).

2. Process Device Manager

2.1 Overview of the process device manager

The process device manager (PDM) is a software package that manages field devices connected with MICREX-NX. This package facilitates the integration of process data from process devices on the PROFIBUS and also device diagnostic information and device characteristic information, and as a result, enables the acquisition of comprehensive diagnostic information from each device, and basic information from diagnostic technology which is capable of detecting the diagnostic information of plants and machinery. Based on

*1: SIMATIC is a registered trademark of Siemens of Germany.

this information, the efficiency of preventative maintenance such as periodic diagnosis and periodic overhauls of machinery can be improved greatly.

In addition, because the PDM package runs at an integrated engineering environment of MICREX-NX (SIMATIC Manager) so that, the field information and operation management information also can be integrated. The trends toward more intelligent field devices and standardized parameters facilitate the greater use of information throughout the entire lifecycle, from the process planning and engineering through operation and maintenance, and facilitate laborsaving.

The PDM package includes functions for the system configuration, parameterization, self-diagnosis and analysis of intelligent process devices; the PDM can be run at an engineering station (ES), or also can be used as a stand-alone architecture for verifying operation at the time of commissioning. With an electronic device description language (EDDL), the PDM package can support field device characteristic information for process devices connected to the PROFIBUS-DP, as well as for devices connected to a standardized network such as a HART or MOD bus.

This EDDL is supplied by the process device manufacture and is a unified language that describes characteristic parameters of process devices (the temperature, pressure and flow of various field devices). Because the manufactures supply process control devices that contain application information, all the processes that include design, implementation, acceptance testing and shipping can be improved greatly.

2.2 Features of the PDM

Functions and features of the PDM are described below. Figure 1 shows the system configuration and supported devices of the PDM.

- (1) Functions for calibration, adjustment, and changing various parameters of field devices connected to the PROFIBUS-DP/PA
- (2) Self-diagnosis of the device status and communication status of field devices
- (3) Function for comparing online device data with offline device data

Fig.1 System configuration and supported devices of PDM

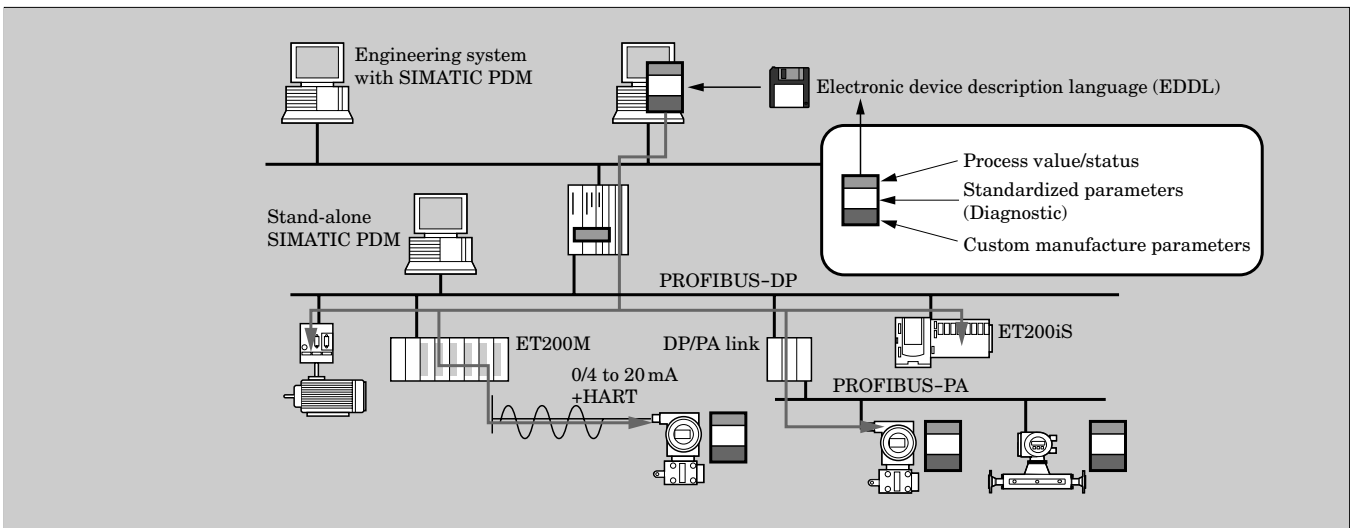

Fig.2 Example of PDM image panel (device parameter view)

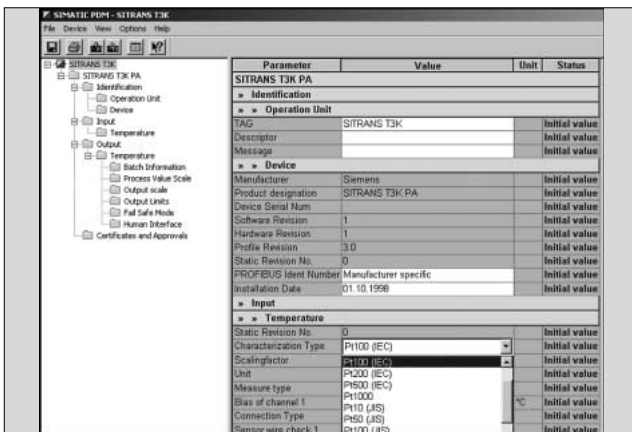
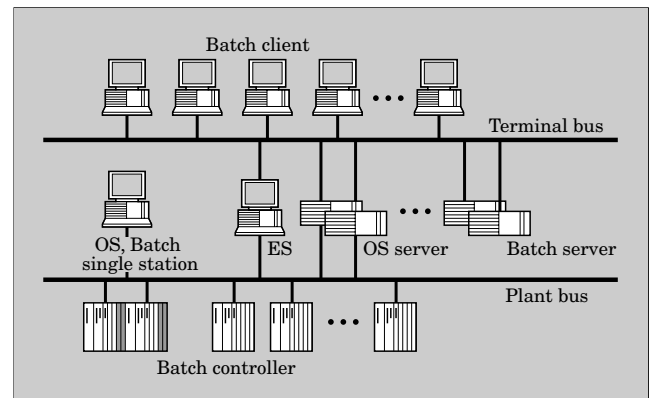

Fig.3 System configuration of batch system



- (4) Function for assigning and configuring slave (network) addresses
- (5) Function for managing, simulating and adjusting test conditions for field devices
- (6) Online monitoring of selected values, alarm and status signals
- (7) Live list for automatic detection of connection status (communication status) of the installed field devices

2.3 Monitor function of the PDM

The PDM displays the following online information in an operator station (OS). Figure 2 shows an example of a displayed image panel.

- (1) Monitor of process device network
Displays the device information, including the diagnostic status, and classifies that information according to the network configuration.
- (2) Monitor of process device plant
Displays the device information, including the diagnostic status of all devices in a network-based system.
- (3) Monitor of field device parameter

Displays the device parameter information in tabular form and/or graphical form.

3. Batch System

3.1 Overview of the batch system

In recent years, quality management and observation of safety-related industrial standards and regulations have been strengthened for food, pharmaceutical and chemical products, and a control system that complies with these regulations is desired. The MICREX-NX batch system is a application software package that complies with regulations related to electronic records and electronic signatures as established by the batch control standard [IEC61512 (ISA S88)] and the United States' Food and Drug Administration (FDA). According to the plant size, the batch system can be configured as an OS single-user system, or a client and server system. The batch system can also be applied to small to large-scale of batch process. Moreover, safety can be enhanced through redundant batch server and batch clients. Figure 3 shows the system configuration.

The batch system is described based on three batch structural models (a procedural model, a physical model, and a process model) that complies with IEC61512 (ISA S88). By introducing the concept of a simple 4-layer structural model and by uniformly describing the connection between models, the batch system provides the capability for design and maintenance. In particular, by using a hierarchical recipes (formula) that affect product quality, each process and field device element in the batch plant is described with a uniform method of expression. Figure 4 shows the batch structural model.

The batch control center centralizes the control of a batch based on system configuration information that

Fig.4 ISA S88-based model of batch system

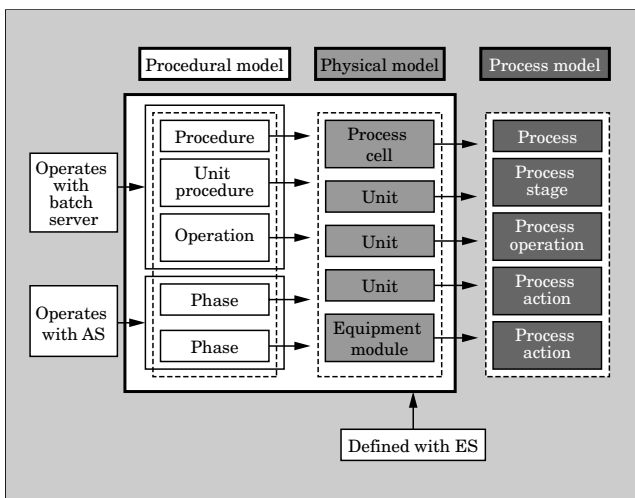
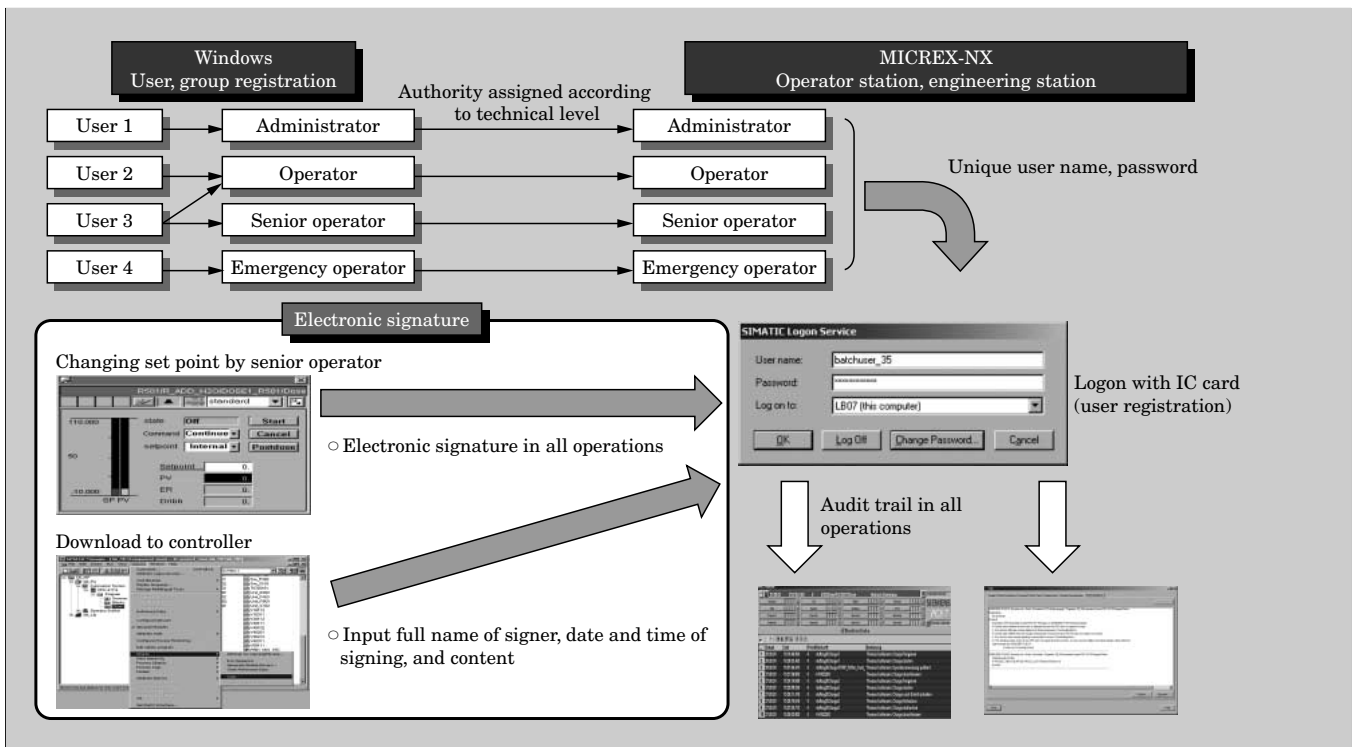

Fig.5 Compliance with FDA 21 CFR Part 11



created with a MICREX-NX engineering station (ES) and a master recipe created with a batch recipe editor. The batch system provides the ability to register and manage required functions as special libraries conforming to the ISA S88.01 structural model. These libraries are described with a sequential function chart (SFC) so that online monitoring and operation can be performed on OS using MICREX-NX standard functions (SFC visualization function). Table 1 shows the software configuration of the batch system. Batch planning can be implemented independently within a batch system using batch control center functions, however, also can combine with upper-level MES package (SIMATIC IT) that compliance with ISA

Table 1 Batch system software packages

Name of software		Main functions	Comments
Basic software	Batch control center	Batch planning, batch control	Batch client
	Batch report	Recipe, batch data printing	Batch client
	Batch recipe editor	Master recipe, library creation, drawing changes	Batch client
	Batch control server	Transmission of batch data (between controller and monitor)	Batch server
Optional packages	Batch planning	Configuration of batch control center	
	Hierarchical recipe	ISA S88.01 compliant recipe	
	API interface	Interface with MES-related software	

Fig.6 Configuration of route control system

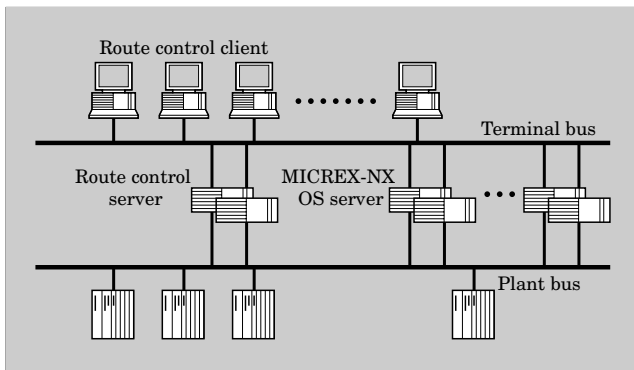

S95.01, enables to develop an information and control system integrated from field level to the product management level.

Additionally, compliance with FDA 21 CFR Part 11 realized high reliability for managing of access security, storage and retrieve manufacturing record data, electronic signature, audit trail, and so on (See Fig. 5).

These functions are based on Windows*2 security functions and an operator access management tool.

3.2 Features of the batch system

The batch system has the following features.

- (1) Structural model and hierarchical recipe compliance with ISA S88.01
- (2) Support from small to large-scale projects by using distributed OS servers that able to access to all control points or by accessing each OS servers.
- (3) Support of FDA 21 CFR Part 11: user management, electronic certification, audit trail, revision control
- (4) High reliable system due to redundant OS servers
- (5) Operating in integrated engineering environment
- (6) OS faceplates for unit, phase and operation

4. Route Control System

The route control system is an software package that monitors, controls and diagnoses systems that transfer fluids through pipes or pipelines. Route control system is mainly used in complex food, pharmaceutical and chemical plants and petrochemical tank yards to realize efficient automatic transfer control for the products.

Figure 6 shows the system configuration and

*2: Windows is a registered trademark of Microsoft Corporation of the USA.

Table 2 System aspect of route control system

Item	Size
AS (automation system)	32 systems (max.)
Number of elements per AS	<ul style="list-style-type: none"> ○ 1,024 motors, dampers, valves, etc. ○ 1,024 link elements, pipeline sections, etc. ○ 1,024 sensor elements, process values ○ 1,024 parameter elements
Parallel transfer routes	300 (max.)
Partial routes	64,000 partial routes (max.)
AS overlapping routes	32 overlapping routes (max.)
Number of elements per route	400 elements per AS (max.)
Number of modes per route	32 modes (max.)

Table 2 lists the system aspect.

The standard engineering features of the MICREX-NX and the main features of route control are listed below.

- (1) Monitoring and control of the transfer route and related elements (such as valves)
- (2) Diagnosis and alert of the transfer route and related elements (such as valves)
- (3) Dynamic linking of partial routes and the entire route
- (4) Engineering of complex route

Route control system can be implemented the standard engineering function of the MICREX-NX system and also can using special library. Moreover, route control system can also be combined with upper-level MES or batch system.

5. Conclusion

In this paper, we introduced advanced information and control packages of MICREX-NX. Such as the PDM package, batch system, and route control system. In addition to these packages the MICREX-NX provides many packages for enhancing the safety and efficiency of a plant, for example safety instrumentation system and compliance with IEC61508 and IEC61511 adaptive control software packages, that are expected in Japan. In the future, Fuji Electric intends to continue its efforts to promote the advanced applications of information and control systems.

Reference

- (1) Theilmann, B.; Edmund, L. Online plant asset management integrated in process control systems. Automation Technology in Practice. 2004-01.