

3-channel DC-DC Converter Control IC for Liquid Crystal Displays

Masanari Fujii

1. Introduction

As multimedia becomes more pervasive in our society, there has been a trend for electronic devices to be made lighter in weight, smaller in size and to consume less power. Such features are fully leveraged by liquid crystal displays (LCDs), and in the display device field, the LCD is rapidly supplanting the conventional CRT.

At present, the replacement of CRTs with LCDs has become commonplace. As the size of display devices increases in the future, user demand is expected to increase for large-screen LCDs having light weight, small size and low power consumption. Lower prices, however, will be a critical factor in the promotion and popularization of these LCDs.

Three types of voltages from a boost converter, buck converter and an inverter are typically required to drive an LCD. The specific voltage configuration and power supply sequence required for driving will differ depending on the display manufacturer and model type. Accordingly, there is demand from LCD manufacturers for an improved, highly versatile, power supply IC.

In order to satisfy the abovementioned demand, Fuji Electric, which has previously commercialized a series of power supply ICs for LCD use, has developed and commercialized a new series for use in configuring the power supplies for large-screen LCDs. This new product series is known as the FA7711V, a 3-channel PWM (pulse width modulation) type, switched-mode power supply IC that does not require a buffer for driving an externally attached power MOSFET (metal oxide semiconductor field effect transistor). An overview of the FA7711V is presented below.

2. Product Overview

Figure 1 shows the appearance of FA7711V chips.

2.1 General IC characteristics

The recently developed FA7711V is a power supply control IC for use in large-screen LCDs, and because the FA7711V is capable of directly driving a large-

Fig.1 Appearance of FA7711V

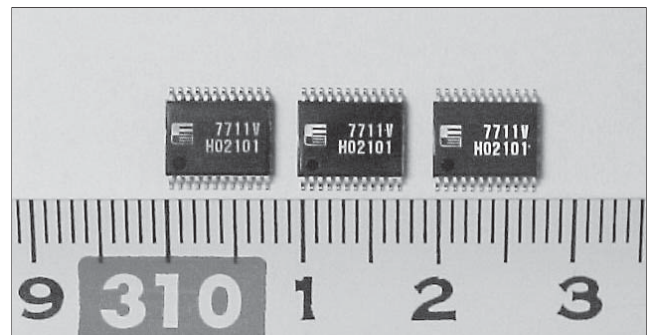

capacity power MOSFET, there is no need for a buffer as was previously required to drive an externally attached power MOSFET. Moreover, 3-channel PWM control output pins are built-in in order to facilitate the configuration of the required power supply for an LCD.

Special features of the FA7711V are as follows:

- (1) Higher efficiency due to high-speed switching is possible since a large-capacity power MOSFET (C_{iss} = approx. 2,000 pF) can be driven directly
- (2) Built-in 3-channel PWM control output pins can be used to configure boost converter, buck converter, inverter and flyback circuits
 - Channel 1
Dedicated for p-channel MOS driving (buck converter)
 - Channel 2, Channel 3
Switchable for n-channel MOS/p-channel MOS driving (boost, buck, inversion). OUT2 and OUT3 have opposite phases. Polarity is set individually with polarity select pins.
- (3) Wide operating range of power supply voltage: 4.5 to 15 V
- (4) High frequency operation of 200 to 800 kHz is possible. Operating frequency can easily be set with a timing resistor.
- (5) Reference voltage: 3.70 V ($\pm 1\%$ precision)
- (6) Low current consumption due to CMOS process (7 mA during operation)
- (7) Each channel has an independent soft start circuit and an individually settable maximum duty
- (8) Independent built-in timer and latch-type short

circuit protection for each channel

- (9) Built-in undervoltage lockout circuit
- (10) Small, low-profile TSSOP-24 pin package (installed height 1.20 mm max.)

2.2 Description of operation

Figure 2 shows a block diagram of the internal circuitry of the FA7711V. The operation of the various sections is described below.

Fig.2 FA7711V internal circuitry block diagram

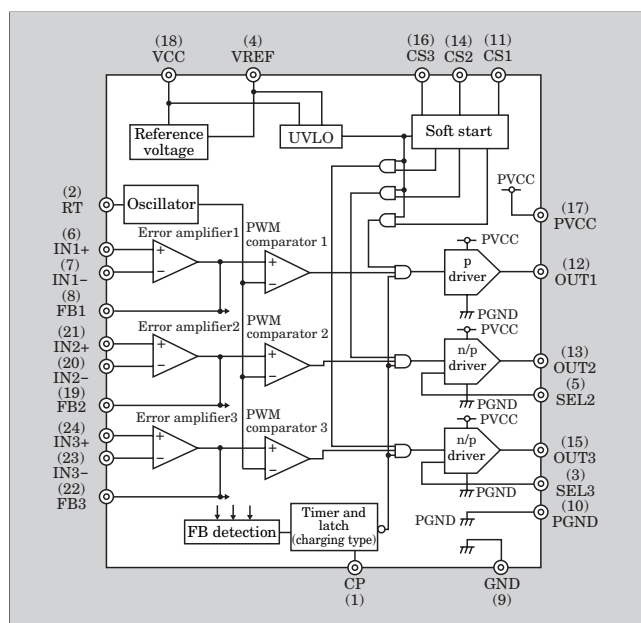

(1) PWM control unit

Reference voltages may be individually set for each channel by inputting an external voltage in the range of 1.3 to 2.3 V to the non-inverting input pin (IN+) on error amplifiers.

Output polarity is set with the polarity select pin (SEL). Moreover, the phases of channels 2 and 3 are inverted, and when driving a power supply, input ripple can be reduced by distributing the load of the input power supply.

(2) Maximum duty setting

In the case of boost converter and inverter driving, it is necessary to limit the maximum duty in order to prevent a short circuit between ground and the power supply input from an externally attached power MOSFET that is fully on. For this reason, a maximum duty can be set by inputting a voltage in the range of 1.3 to 2.3 V to the soft start pin (CS) of each channel.

(3) Soft start circuit

At startup, an independent soft start circuit for each channel gradually extends the duty cycle in order to prevent current in-rush of the input power supply and overshoot of the power supply output voltage. The soft start pins (CS) have a built-in current source and therefore are used with an external capacitor connected.

(4) Timer and latch-type short circuit protection

A timer and latch-type short-circuit protection circuit monitors the voltage output from each error amplifier for abnormalities, and after a certain delay time has elapsed, halts the IC output. The delay time

Fig.3 FA7711V application circuit example

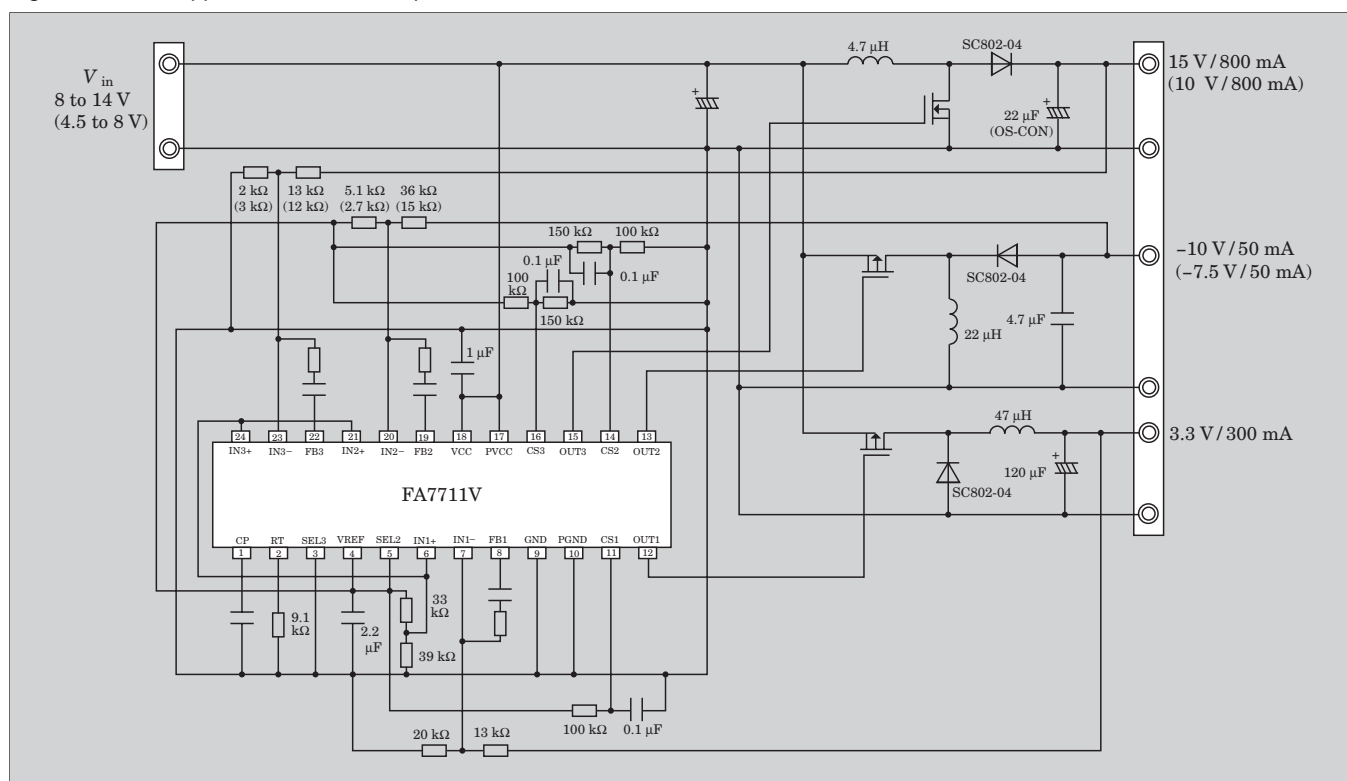
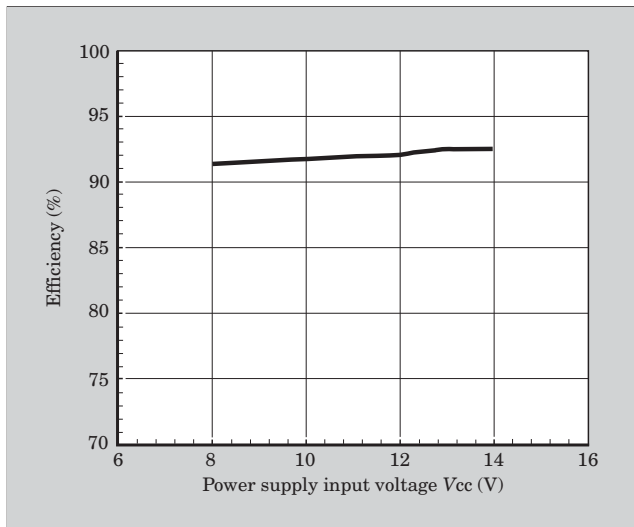

Fig.4 Voltage conversion efficiency for input voltages of 8 to 14 V (560 kHz switching)



can be set with the capacitor connection (CP) pin that interfaces to the built-in timer and latch provided with an internal current source.

(5) Undervoltage lockout circuit

If the voltage of the power supply input pin (VCC) and reference voltage output pin (VREF) drop to 3.3 V or less, the output from all channels is halted.

(6) Oscillator

The frequency of the oscillator can be set to an arbitrary value in the range of 200 to 800 kHz by connecting a resistor (28 to 6 kΩ) to the timing resistor pin (RT). The oscillation waveform has an amplitude of 1.3 to 2.3 V, and is supplied as the reference voltage for the PWM comparator of each channel.

3. Circuit Application Example

Figure 3 shows an example circuit application of the FA7711V. A change in the input voltage range results in a change in the output voltage, and the circuit constant for the output voltage detection resistor will be modified. If the input voltage is more than 8 V, the input and output conditions of the power supply are as follows:

- (1) Input voltage (V_{in}) 8 to 14 V
- (2) Output voltage (V_{out})
 - Channel 1: Buck (3.3 V / 300 mA)
 - Channel 2: Inversion (-10 V / 50 mA)
 - Channel 3: Boost (15 V / 800 mA)

The power conversion efficiency (= output power / input power) in this case is shown in Fig. 4. IC loss is suppressed due to high-speed switching at the output stage and a high efficiency of 91 to 93 % is realized.

Fig.5 Voltage conversion efficiency for input voltages of 4.5 to 8 V (560 kHz switching)

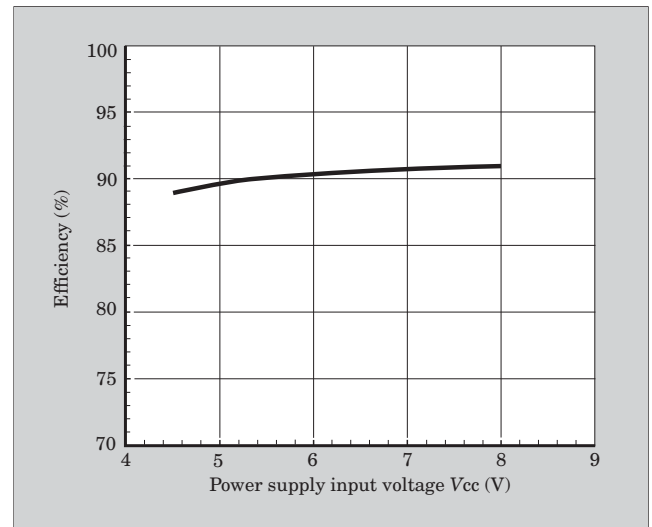

If the input voltage does not exceed 8 V, the input and output conditions of the power supply are as follows.

- (1) Input voltage 4.5 to 8 V
- (2) Output voltage
 - Channel 1: Buck (3.3 V / 300 mA)
 - Channel 2: Inversion (-7.5 V / 50 mA)
 - Channel 3: Boost (10 V / 800 mA)

Figure 5 shows the power conversion efficiency in this case. Since the input voltage is low, power conversion loss increases by the amount of loss generated in elemental resistors due to increased line current. Consequently, efficiency is less than in the case where input voltage is greater than 8 V. Nevertheless, a relatively high efficiency of 89 to 91 % is obtained.

4. Conclusion

An overview of the FA7711V power supply control IC for LCD-use has been presented.

At present, in the display device field, the conventional CRT monitor is rapidly being supplanted by LCDs of all sizes, and demand is growing for power supplies that are smaller, thinner and consume less power. Moreover, demand for lower priced LCDs is driving the need to lower the cost of the power supply, for which the elimination of components externally attached to the IC is an important factor. In response to these market demands, Fuji Electric intends to further advance its series of power supply control ICs for LCD-use by developing ICs that have built-in power MOS circuitry, for example.