

# Cooperative University-Industry Research with Zhejiang University: Toward the Creation of Smart Grid Related Business

Yun Lei † Kimihisa Kaneko † Naoto Kobayashi †

## ABSTRACT

In China, the economy has continued to grow and the market has continued to expand since the year 2000. To develop and produce products that meet the needs of customers in China, Fuji Electric has established cooperative relationships with several Chinese universities and is engaged in cooperative research in university-industry partnerships. Specifically, Fuji Electric and Zhejiang University have entered into a comprehensive agreement and are advancing a unique partnership that aims to advance research work for the creation of new products and new business and also to promote activities that will contribute positively to society. Building upon the prior development work and field testing of systems that comply with GB standards (Chinese national standards) for power quality measurement in a distribution system, this collaboration will endeavor to expand smart grid related business to the field of power stabilization technology.

## 1. Introduction

In the 1990s, as a result of China's policies of reform and opening-up, many foreign companies decided to move into China. With the launching of a new base for motor manufacturing, Fuji Electric also began to move into China.

In the 2000s, market in China has expanded as its economy has developed, and in preparation for the 2008 Beijing Olympics, infrastructure development has been advanced at a rapid pace. Under these circumstances, in order for foreign companies in China to expand their business into the Chinese market, not just low cost manufacturing, but also product development and manufacturing suited to the needs of Chinese customers have come to be strongly required. In response, Fuji Electric is establishing cooperative relationships with many Chinese universities, and has entered into a comprehensive partnership with Zhejiang University. This paper introduces the university-industry partnership between Fuji Electric and Zhejiang University, and efforts to create business opportunities relating to smart grids.

## 2. Characteristics of Universities in China

Owing to their political, national, cultural and historical backgrounds, universities in China have the following characteristics.

- (a) Close relationship with government
- (b) "Old boy" network cultivated through dormitory life
- (c) Contributor to Chinese company research
- (d) Research and development supported by an abundance of graduate students

- (e) Active business management and university-industry collaboration

There is an active exchange of personnel between universities and governments/administrative authorities. As a result, networks closely connected with industry, government, academia and research institutions are formed and have a significant impact on government policy.

All university students live in dormitories, and this student lifestyle fosters a strong sense of camaraderie that continues even after graduation. Eighty-four percent of graduates find jobs with private companies, and corporate ties using "old boy" networks are utilized extensively. Also, 14% of graduates find jobs in the government sector, further strengthening the ties between one's alma mater and industry, government and academia.

Thirty-five percent of corporate research and development expenditures in China in 2008 were outsourced to universities, a high percentage that is approximately 12 times greater than that of Japan, and is an indication of the active collaborations between industry and academia. The research outsourced from companies is performed mostly by graduate students under the guidance of professors. The number of these graduate students is about 13 times that of Japanese universities.

Many examples exist of universities themselves managing companies, and there is a strong entrepreneurial mindset. The total revenue obtained from corporate management by the top 20 Chinese universities in 2009 was 120 billion yuan (approximately 1.48 trillion yen).

In this way, Chinese universities exert a much greater influence on domestic industry than Japanese universities.

† Fuji Electric Co., Ltd.

### 3. University-Industry Partnership With Zhejiang University

In Japan, some companies also utilize research at Chinese universities as one part of their research and development base<sup>(1)</sup>. These university-industry partnerships, in addition to being an efficient use of research and development funds, are also reported to be advantageous for forming networking contacts, acquiring expertise in areas of academic research, and so on. On the other hand, the need to manage intellectual property carefully and to pay close attention to compliance with the laws of Japan and China has also been reported.

Fuji Electric, having fully analyzed and considered such advantages and disadvantages in conjunction with its relevant departments and affiliates, is developing university-industry partnerships as part of its business expansion in China.

In 2004, Fuji Electric entered into a university-industry partnership with Zhejiang University, and began research and development work. Then, in April 2006, Fuji Electric and Zhejiang University entered into a comprehensive collaborative agreement, establishing the “Zhejiang University – Fuji Electric Systems Research and Development Center” at Zhejiang University, and expanding their university-industry collaboration over many fields. Building upon the positive results obtained from specific activities over four years, and in order to strengthen cooperation for the creation of additional business, Fuji Electric founded the “Zhejiang University – Fuji Electric Innovation Center” in April 2010 to enlarge the scope of collaboration and to promote various collaborative activities.

#### 3.1 Individual research

Fuji Electric and Zhejiang University have maintained a certain relationship at the researcher level since the 1990s. To further expand business in China, in 2004, Fuji Electric conducted a feasibility study in the power supply field.

#### 3.2 Zhejiang University – Fuji Electric Systems Research and Development Center

In the research and development of basic and applied technologies in China, in addition to conducting individual research in specific technical fields as in the past, from the medium and long-term perspective, there is a need for collaborative activities and close cooperation in many technical fields in order to advance research. For this purpose, Fuji Electric Systems Co., Ltd.\*1, the principal operating company of the collaborative research project with Zhejiang University, established and operated the “Zhejiang – Fuji Electric

\*1: Fuji Electric Systems Co., Ltd.: Merged with Fuji Electric Holdings Co., Ltd. in April 2011 to create the present Fuji Electric Co., Ltd.

Systems Research and Development Center” for a period of 4 years, beginning in April 2006.

At this Center, more than 10 research projects were initiated in electrical and other fields, and research and development as well as demonstration experiments were carried out, resulting in patent applications, published papers, and so on.

One activity of this Center is to foster personnel exchanges and educational cooperation, and technical exchange meetings were held for specific technical fields, such as power electronics, to promote mutual understanding in academia and industry. Additionally, Zhejiang University professors also held educational activities for employees of Fuji Electric’s base in China, and the collaboration was expanded to include technical exchanges with relevant affiliates. The diverse range of activities over these 4 years resulted in a closer partnership and greater mutual trust by both sides.

#### 3.3 Zhejiang University – Fuji Electric Innovation Center

Based on the mutual trust cultivated with Zhejiang University, and in consideration of the benefits of cooperation in a wider range of fields and the need for activities that emphasize new business creation in addition to new product development, Fuji Electric has decided to adopt a collective approach as entire group. Accordingly, in April 2010, Zhejiang University and Fuji Electric Holdings Co., Ltd. established the “Zhejiang University – Fuji Electric Innovation Center” in the Zhejiang University campus.

Global warming and climate change are becoming serious problems at the global level and in order

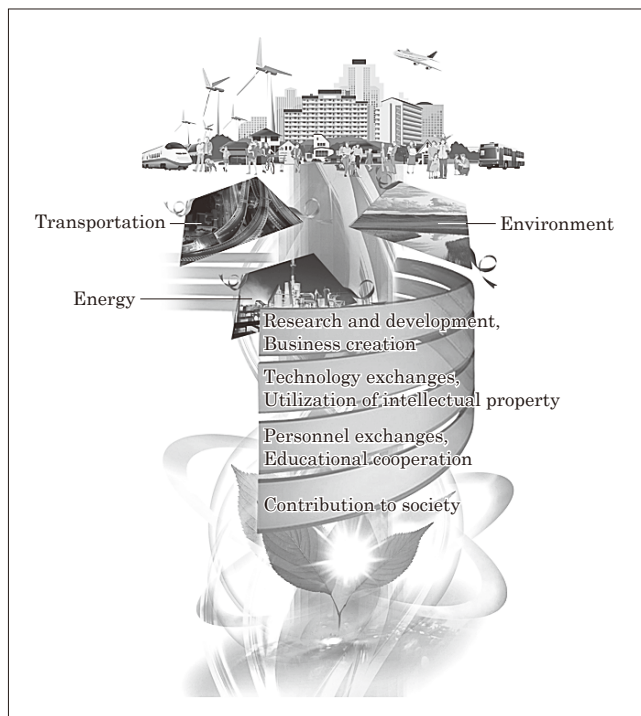

Fig.1 Key business areas and activities

to contribute to solving these problems Fuji Electric is focusing on the “energy and environment” business field, and intends to expand businesses globally in this field. For this purpose, the technology and human resources of Zhejiang University and the technology and business experience of Fuji Electric are leveraged to strengthen business creation activities primarily in the “energy and environment” field.

Efforts at the Center, mainly in the three business fields of energy, environment and transportation, are concentrated on the four activity areas of research and development and business creation, technological exchanges and utilization of intellectual property, personnel exchanges and educational cooperation, and partner cultivation and societal contributions (see Fig. 1).

#### 4. Initiatives in smart grid-related fields

In the field of power systems, one of the fields in the energy business sector, university-industry partnerships are expanding through a three-tier framework (see Table 1), whereby a feasibility study of the power system business in China was conducted first, then product development and demonstration projects

Table 1 Framework of university-industry partnerships

Organization	2004 to 2005	2006 to 2009	2010 to 2013
Individual research	Chinese power supply business feasibility study		
Zhejiang University – Fuji Electric Systems Research and Development Center		Product development and demonstration projects	
Zhejiang University – Fuji Electric Innovation Center			Smart grid-related business creation

Table 2 Implemented items in the electric power system field

Power-related cooperation phase	Items implemented	Achievement
Chinese power system business feasibility study	Of the technology owned by Fuji Electric, adaptability in the Chinese market was analyzed for 7 fields	Identification of 3 high-priority technical fields (a) DMS field (b) PQ field (c) EMS field
Product development and demonstration projects	Development in the identified fields: ○ Localization of distribution automation system ○ Field trial of wide-area PQ* measurement system, Development of complex PQ* countermeasure devices ○ Development and application of system-wide VQ* control algorithms	○ Acquisition of certification for wide-area PQ* measurement system ○ Practical application at power utilities
Smart grid-related business creation	○ Demonstration of smart grids ○ Development of system-related simulation models, etc.	○ Business creation

\* PQ : Power Quality

\* VQ : Voltage Q (reactive power)

were carried out, and at present, smart grid-related business creation is being expanded. Table 2 lists items implemented in the power system field, and details are presented below.

#### 4.1 Chinese power system business feasibility study

From 2004 to 2005, Fuji Electric conducted a feasibility study of the power system business in China.

With its rapid economic growth, the demand for power in China increases day by day. As the capacities of large-scale power facilities are increased, improvements in power transmission and distribution systems are also expected. Having acquired power system development and automation experience during periods of high growth in Japan, Fuji Electric’s power system monitoring and control technology is considered to be essential for China. To expand Fuji Electric’s business opportunities in the electric power field in China, the first step was to conduct a feasibility study of the power system business in China.

Fuji Electric’s proprietary technology was analyzed and studied with regard to its applicability and business potential in the Chinese market in the following seven areas: energy management systems (EMS), distribution management systems (DMS), automatic meter reading (AMR), power quality (PQ) measurement and countermeasures, energy conservation, new energy, and electricity trading market. The results indicated that, in the near future, power infrastructure in China will require DMS effective for reducing the annual downtime and increasing the efficiency of power distribution equipment investment, PQ measurement and countermeasures effective for assessing the power quality, i.e., high frequency harmonics, instantaneous voltage drops and the like, and EMS and AMR effective for increasing the efficiency of supply-demand balance control, including energy conservation.

Fuji Electric has identified the following three areas as high-priority technical fields, and is moving ahead with research and development for the Chinese

market.

- (a) DMS field
- (b) PQ field
- (c) EMS field

#### 4.2 Product development and demonstration projects

From 2006 to 2009, at the Zhejiang University – Fuji Electric Systems Research and Development Center, product development and demonstration experiments were carried out for the three technical fields identified in the feasibility study.

In the DMS field, the many proven DMS solutions of Japanese power companies were additionally developed and localized so that the capability to interface with other systems, the accident recovery sequence and so on would accommodate the operational management rules and structure of Chinese power companies.

In the PQ field, power measurement terminals that comply with GB standards (Chinese national standards) were developed, and field trials of a wide-area PQ measurement system (Fig. 2) that uses an actual power company system and its information infrastructure were carried out. Typical problems with the power quality in China were analyzed and power electronics devices were researched and prototypes were developed in order to realize complex PQ countermeasures. Additionally, system-wide VQ (Voltage Q (reactive power)) control algorithms were developed to control voltage and reactive power throughout the entire system, including the power transmission and distribution system, and a certain power company has applied these algorithms.

In the EMS field, electric power load prediction and how to control limited power supply facilities so as to best accommodate load fluctuations are major challenges. Fuji Electric has researched and analyzed various load leveling control methods, such as the use of power pumped-storage power generation and chiller cooling systems to shift power utilization to low-load (nighttime) hours.

Through such specific research and development activities, the characteristics and technical challenges

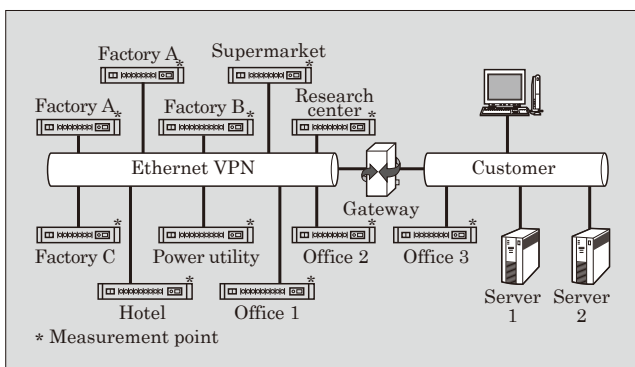

Fig.2 Overview of wide-area PQ measurement system

of power systems in China have come to be understood. In addition, by carrying out demonstration trials at power companies, the adaptability of Fuji Electric's proprietary technology to the Chinese market was confirmed. The results of these activities led to the acquisition of certification of a wide-area PQ measurement system, which directly tied to business opportunities.

#### 4.3 Creation of smart grid-related business

From 2010 to 2013, the Zhejiang University – Fuji Electric Innovation Center is endeavoring to create smart grid-related business opportunities.

Since the global financial crisis, in order to prevent global warming and as economic policy, smart grids have attracted attention as a way for realizing more efficient power systems and to help popularize new type of energy. Several national key projects (National High-tech Research and Development Programs) have been conducted at Zhejiang University so far. Especially noteworthy is the recent involvement in a national key project for conducting demonstrations related to smart grid usage on remote islands. Based on established power system monitoring control technology and a business infrastructure, Fuji Electric is endeavoring to create new smart grid-related business that will fully utilize power electronics, an area of technical strength of Fuji Electric.

This Center is advancing smart grid demonstration projects, including the development of new energy system interconnection simulation models and the localization of power system stabilization technology, for systems that strive to achieve a renewable energy system that combines safe, reliable energy with environmental technologies and a self-sufficient balance system.

#### 5. Postscript

Energy policy is being reviewed as a consequence of the Great East Japan Earthquake of March 11, 2011. As renewable energies such as solar and wind power become widespread, and load leveling by storing electric power and power system stabilization is needed increasingly, those trends will expand globally, and such needs will increase further in China as well. Fuji Electric, based on its wealth of accumulated technology, intends to create smart grid related business opportunities in China in order to contribute to economic development and to help resolve environmental problems in China.

#### References

- (1) Jianmin Jin. Japanese Enterprises and R&D Activities by Multinational Enterprises in China. Fujitsu Research Institute. Reserch Report. No. 270, July 2006.



\* All brand names and product names in this journal might be trademarks or registered trademarks of their respective companies.